

Contract Documents

for the
Knott Landfill – Cell 9 Construction Project



Prepared for:
Deschutes County
Department of Solid Waste
61050 SE 27th Street
Bend, Oregon 97702

Prepared by:

G. Friesen Associates, Inc.
4088 Orchard Drive
Lake Oswego, Oregon 97035 - (971) 235-3317

In Association with:

Siemens & Associates
Tent Engineering Inc.
John Thompson & Associates
Peak GeoSolutions

August 24, 2023

**Contract Documents for the
Knott Landfill – Cell 9 Construction Project**

TABLE OF CONTENTS

	ITEM	NUMBER OF PAGES
Part I	Invitation to Bid	2
Part II	Information for Bidders	6
Part III	General Conditions	8
Part IV	Special Provisions	71
Part V	Bid Proposal Forms	
	Bid Proposal	1
	Bid Schedule	3
	Bid Bond	1
	Subcontractor Disclosure	1
Part VI	Agreement Forms	
	Contract	2
	Performance Bond	2
	Payment Bond	2
	Certificate of Insurance	2
Part VII	Geotechnical Site Conditions	30
Part VIII	Knott Landfill - Conditional Use Permit for Crushing and Storage of Excavated Material	24
Part IX	Contract Drawings	24
Part X	Standard Drawings	2

PART I
INVITATION TO BID

**Deschutes County, Oregon
Department of Solid Waste
INVITATION TO BID**

Knott Landfill Cell 9 Construction Project

Sealed bids will be received at the Deschutes County Department of Solid Waste, 61050 SE 27th Street, Bend, Oregon 97702, until but not after, 2:00 p.m. on October 4, 2023; at which time all bids for the above-entitled solid waste project will be publicly opened and read aloud. Bidders must submit a First Tier Subcontractor Disclosure Statement Form. The Subcontractor Disclosure Statement may be submitted in the sealed bid prior to 2:00 p.m. on October 4, 2023 or in a separate sealed envelope marked "FIRST TIER SUBCONTRACTOR DISCLOSURE STATEMENT-KNOTT LANDFILL CELL 9 CONSTRUCTION PROJECT" prior to 4:00 p.m. on October 4, 2023 at the above location.

Said work is to be performed at the Knott Landfill located in Bend, Oregon and shall include: excavation for a refuse cell; construction of embankments; installation of geosynthetics; installation of soil materials for cushioning, and drainage; construction of leachate collection systems; installation of landfill gas piping systems; installation of chain link fence; and installation of asphalt concrete pavement. The estimated construction cost is \$ 6,000,000 to \$ 8,000,000.

Plans, specifications and other bid documents may be inspected at the Deschutes County Department of Solid Waste website (<http://www.deschutes.org/rfps>) or obtained from Deschutes County Department of Solid Waste (541-317-3163), 61050 SE 27th Street, Bend, Oregon 97702, for a fee of \$50.00, which is not refundable. If you wish to have them mailed to you, enclose an additional \$5.00 with your request. Should expedited handling be desired, Federal Express or equivalent service will be utilized on a collect on delivery basis. Inquiries pertaining to this project shall be directed to Gerry Friesen of G. Friesen Associates, Inc. at (971) 235-3317.

A pre-bid meeting will be held at 1:30 p.m. on September 20, 2023 at the Department of Solid Waste Office which is located at 61050 SE 27th Street, Bend, Oregon. A tour of the project site will be part of this meeting. Attendance at the pre-bid construction meeting is optional.

IMPORTANT: Prospective proposers downloading/accessing website-posted project plans, specifications and other bid documents MUST complete and submit the Contact Information Form provided on the website, or contact the Department of Solid Waste by telephone at (541) 317-3163, to provide contact information, to receive follow-up documents (addenda, clarifications, etc). Failure to provide contact information to the Department of Solid Waste will result in proposer disqualification. Only those registered with the Department of Solid Waste will receive follow-up documents (addenda, clarifications, etc).

Bids shall be made on the forms furnished by the County, incorporating all contract documents, including a Bid Bond or Cashier's Check for the minimum amount of 10% of the Bid Price, addressed and mailed or delivered to Deschutes County Department of Solid Waste, 61050 SE 27th Street, Bend, Oregon 97702 in a sealed envelope plainly marked "Knott Landfill Cell 9 Construction Project" along with the name and address of the bidder.

No bid will be considered by Deschutes County unless the bid contains a statement by the bidder that the provisions of ORS 279C.800 – 279C.870 are to be complied with. Each bid must contain a statement as to whether the bidder is a resident bidder, as defined in ORS 279A.120.

Bidders shall be prequalified with the State of Oregon in accordance with ORS 279C.430 – 279C.450 and Deschutes County Code 12.52.020. The prequalification classification required for this project is "Earthwork and Drainage Construction." The successful bidders and subcontractors providing labor shall maintain a qualified drug testing program for the duration of the contract. Bidders shall be licensed with the Construction Contractor's Board. Contractors and subcontractors need not be licensed under ORS 468A.720.

Deschutes County may reject any bid not in compliance with all prescribed bidding procedures and requirements, and may reject for good cause any or all bids upon a finding of Deschutes County it is in the public interest to do so. In addition, Deschutes County may, at its sole discretion, and at any time before a contract is awarded, reject all bids and cancel this Invitation to Bid. The protest period for this procurement is seven (7) calendar days.

Tim Brownell,
Director of Solid Waste

PUBLISHED:

THE BEND BULLETIN: September 6, 2023 and September 8, 2023

DAILY JOURNAL OF COMMERCE: September 6, 2023 and September 8, 2023

Part II
INFORMATION FOR BIDDERS

INFORMATION FOR BIDDERS

1. **General Description of Project.** A general description of the work to be performed is contained in the Invitation to Bid. The scope is indicated in the applicable parts of these Contract documents.
2. **Contract Documents.** The Contract documents under which it is proposed to execute the work consist of the material bound herewith. These Contract documents are intended to be mutually complementary and to provide all details reasonably required for the execution of the proposed work.

Any person contemplating the submission of a proposal and being in doubt as to the meaning or intent of said contract document shall at once notify, in writing, the Solid Waste Department Director of Deschutes County, Oregon. Any interpretation of change will be mailed or delivered to each person receiving a set of documents.

3. **Form of Proposals.** All proposals must be submitted on the forms furnished. Subcontractor disclosure form may be submitted with bid or in a separate envelope.
4. **Substitutions.** Materials and/or products called for in the specifications are named in order to establish standards of quality and design. Where permitted in the specifications, bidders may submit bids containing materials and/or products that are equal in quality and design to those specified. The Director of Solid Waste or his representative shall have sole discretion in determining whether the proposed materials and/or products are equal in quality and design to those specified. Material and/or product reviews will be in accordance with Section 01340 of the Special Provisions.
5. **Preparation of Proposals.** All blank spaces in the proposal form must be filled in, in ink, or typed, in both words and figures where required. No changes shall be made in phraseology of the forms. Written amount shall govern in cases of discrepancy between the amount stated in writing and amount stated in figures.

Any proposal shall be deemed informal which contains omissions, erasures, alterations, or additions of any kind, or prices uncalled for, or which, in any manner shall fail to conform to the conditions of the published invitation to bidders.

The bidder shall sign his proposal in the blank space provided therefore. Proposals made by corporations or partnerships shall contain names and addresses of the principal officers or partners therein. If a corporation makes a proposal, it must be signed by one of the principal officers thereof, and the corporate seal affixed.

If made by a partnership, it must be signed by one of the partners, clearly indicating that he is signing as a partner of the firm. In the case of a proposal made by a joint venture, each of the joint venturers must sign the proposal in his personal capacity.

The wording of the proposal shall not be changed. Any additions, conditions, limitations or provisions inserted by the bidder will render the proposal irregular and may cause its rejection.

6. **Submission of Proposals.** All proposals must be submitted in the time and place and in the manner prescribed in the Invitation to Bid. Proposals must be made on the prescribed proposal forms furnished. Each proposal must be submitted in a sealed envelope, so marked as to indicate its contents without being opened. If the proposal is submitted by mail, the sealed envelope containing the bid must be enclosed in a separate envelope plainly addressed for mailing to conformance with instructions in the Invitation to Bid. **NOTE: A proposal must include a completed original set of all forms provided in Part V-Bid Proposal Forms of these Contract Documents.**

7. **Withdrawal of Proposal.** Proposals may be withdrawn prior to the scheduled time for the opening of the proposals either by electronic facsimile (541-317-3959), email (Jeff.Merwin@deschutes.org) or in person. No proposal may be withdrawn after the time scheduled for opening of proposals, unless the County has failed to comply with the time limits applicable to award of the Contract.
8. **Proprietary Information.** The County is subject to the Oregon Public Records Law (ORS 192.311 to 192.431), which requires the County to disclose all records generated or received in the transaction of County business, except as expressly exempted in ORS 192.345, 192.355, or other applicable law. Examples of exemptions that could be relevant include trade secrets (ORS 192.345 (2)) and computer programs (ORS 192.345(15)). The County will endeavor not to disclose records submitted by a Proposer that are exempt from disclosure under the Public Records Law, subject to the following procedures and limitations.
- a) The entire response to this Invitation to Bid cannot be marked confidential, nor, shall any pricing be marked confidential.
 - b) All pages containing the records exempt from disclosure shall be marked “confidential” and segregated in the following manner:
 - c) The cover page of the confidential documents must be red, and the header or footer for each page must provide as follows: “Not Subject to Public Disclosure.”
 - d) It shall be clearly marked in bulk and on each page of the confidential document.
 - e) It shall be kept separate from the other Invitation to Bid documents in a separate envelope or package.
 - f) Where this specification conflicts with other formatting and response instruction specifications, this specification shall prevail.
 - g) Where such conflict occurs, the Proposer is instructed to respond with the following: “Refer to confidential information enclosed.”
 - h) This statement shall be inserted in the place where the requested information was to have been placed.

Proposers who desire that information be treated as confidential must mark those pages as “confidential,” cite a specific statutory basis for the exemption, and the reasons why the public interest would be served by the confidentiality. Should a proposal be submitted as described in this section no portion of it can be held as confidential unless that portion is segregated as described in the criteria in subsection c above.

Notwithstanding the above procedures, the County reserves the right to disclose information that the County determines, in its sole discretion, is not exempt from disclosure or that the County is directed to disclose by the County’s Attorney, the District Attorney or a court of competent jurisdiction. Prior to disclosing such information, the County will notify the Proposer. If the Proposer disagrees with the County’s decision, the County may, but is not required to enter into an agreement not to disclose the information so long as the Proposer bears the entire cost, including reasonable attorney’s fees, of any legal action, including any appeals, necessary to defend or support a no-disclosure decision. Where authorized by law, and at its sole discretion.

9. **Disclosure of First Tier Subcontractors.** Bidders must submit a First Tier Subcontractor Disclosure Statement where the bid exceeds \$100,000. The subcontractor disclosure statement may be submitted in the sealed bid prior to the bid closing OR it may be submitted in a separate sealed envelope marked “FIRST TIER SUBCONTRACTOR DISCLOSURE STATEMENT” and the name of the project, within two (2) working hours after the bid closing. Bidder must submit a First Tier Subcontractor Disclosure Statement on the form provided in these contract documents identifying all first-tier subcontractors that will furnish labor or labor and materials and whose contract value is equal to or greater than:

- a) 5% of the total project bid, but at least \$15,000, or
- b) \$350,000 regardless of the percentage of the total project bid.

To determine disclosure requirements, it is required that bidders disclose subcontract information for any subcontractor as follows:

- a) Use the forms bound herewith for the required disclosure.
- b) Bidder's Requirements: Bidders are required to disclose information about certain first-tier subcontractors when the contract value for a Public Improvement is greater than \$100,000 (see ORS 279C.370). Specifically, when the contract amount of a first-tier subcontractor furnishing labor or labor and materials would be greater than or equal to: (i) 5% of the project bid, but at least \$15,000, or (ii) \$350,000 regardless of the percentage, the bidder must disclose the following information about that subcontract either in its Bid submission or within two working hours after bid closing:
 - 1) The subcontractor's name,
 - 2) The anticipated amount of the subcontract, and
 - 3) The category of work that the subcontractor would be performing.
- c) If the bidder will not be using any subcontractors that are subject to the above disclosure requirements, the bidder is required to indicate "NONE" on the accompanying form.
- d) Bidder shall submit the disclosure form required by OAR 137-049-0360 either in its bid submission or separately within two working hours after Bid Closing in the manner specified by the invitation to bid.
- e) Compliance with the disclosure and submittal requirements of ORS 279C.370 and OAR 137-049-0360 is a matter of Responsiveness. Bids which are submitted by Bid Closing, but for which the disclosure submittal has not been made by the specified deadline, are not responsive and shall not be considered for Contract award.
- f) County shall obtain, and make available for public inspection, the disclosure forms required by ORS 279C.370 and OAR 137-049-0360. County shall also provide copies of disclosure forms to the Bureau of Labor and Industries as required by ORS 279C.835. County is not required to determine the accuracy or completeness of the information provided on disclosure forms.
- g) Substitution of affected first-tier subcontractors shall be made only in accordance with ORS 279C.585. County shall accept written submissions filed under the statute as public records. Aside from issues involving inadvertent clerical error under ORS 279.585(5), County does not have a statutory role or duty to review, approve, or resolve disputes concerning such substitutions. See ORS 279C.590 regarding complaints to the Construction Contractors Board on improper substitution.

THE COUNTY MUST REJECT A BID IF THE BIDDER FAILS TO SUBMIT THE DISCLOSURE FORM WITH THIS INFORMATION BY THE STATED DEADLINE (see OAR 137-049-0360).

- 10. **Bid Security.** The Bid Bond or Cashier's Check will be for a minimum of ten per cent (10%) of the amount of the bid price. If a bidder bids more than one bid proposal, each proposal must be accompanied by separate bid security. The County reserves the right to retain the bid security of the three (3) lowest bidders until the successful bidder has signed and delivered the contract and furnished a one hundred percent (100%) Performance and Payment Bond.
- 11. **Conditions of Work.** Each bidder must inform himself of the conditions relating to the execution of the work, and make himself thoroughly familiar with all the Contract documents. Failure to do so will not relieve the successful bidder of his obligations to enter into a Contract and complete the contemplated work in strict accordance with the Contract documents.

Each bidder must inform himself on all laws and statutes, both Federal and State, relative to the regular execution of the work, the employment of labor, protection of public health, access to the work and similar requirements.

12. **Award of Contract.** The award of the contract, if any, will be made by the County on the basis of the proposal which in its sole and absolute judgment will best serve the interest of the County. The County shall have the right to accept Alternates, in any order or combination and to determine the low Bidder on the basis of the sum of the Base Bid and the Alternates accepted

County will issue a notice of intent to award contract. Any bidder may protest the notice of intent to award contract within seven (7) calendar days of the notice of intent to award contract.

The County reserves the right to accept or reject any or all proposals, and to waive any informalities and irregularities in said proposals. In addition, Deschutes County may, at its sole discretion, and at any time before a contract is awarded, reject all bids and cancel this Invitation to Bid.

13. **Payment and Retainage.** Payment for work performed will be made by the County as specified in the Special Provisions based upon the contract unit prices on the Bid Schedule.

Upon substantial completion of the contract, Contractor may request a partial release of retainage held by the County. The maximum amount of a request for a partial release retainage shall be the Contract amount less 150 percent of the estimated cost of the Contract yet to be performed through final completion. Upon final completion, Contractor may request release of the remaining retainage. Each request for the release of retainage shall be accompanied by the Consent of the contractor's surety.

14. **Performance Bond and Payment Bond.** The successful bidder shall file with the County, at the time of execution of the contract, a Performance Bond and Payment Bond each of not less than the contract price on the forms furnished by the County. The Surety Company furnishing the required bonds shall have a sound financial standing and a record of service satisfactory to the County, and shall be authorized to do business in the State of Oregon. In lieu of a Performance Bond, the contractor may file cash, a Certified or Cashier's Check made payable to Deschutes County, Oregon. This money, check or certificate will be held by the County conditioned on and subject to the same provisions as set forth in the attached Performance Bond. ORS 279C.380 allows no flexibility for a cash deposit in lieu of a Payment Bond.

County may request a copy of Contractor's surety bond(s). Contractor must supply County with copy of surety bond(s) within ten (10) calendar days from the date of the request.

15. **Required Public Works Bond** The Contractor and every subcontractor must have a public works bond filed with the Construction Contractors Board, 700 Summer St. NE, Suite 300, Salem, Oregon 97309-5052, before starting work on the project, unless except under section 2 (7) or (8) of 2005 Oregon Laws Chapter 360. Every subcontract to which Contractor is a party for the performance of work under this Contract shall contain a provision requiring the subcontractor to have a public works bond filed with the Construction Contractors Board before starting work on this project, unless exempt under section 2 (7) or (8) of 2005 Oregon Laws Chapter 360.

16. **Failure to Execute Contract.** Upon failure by the successful bidder to enter into the Contract and furnish the necessary bond within ten (10) calendar days from the date Notice of Award is made, the bid security accompanying the bid shall be forfeited, the proceeds paid to the County, and the award withdrawn. The award may then be made to the next lowest responsible bidder, or all bids rejected and work is re-advertised.

17. **Disclaimer of Responsibility.** Neither the County nor the Director of Solid Waste will be responsible for oral interpretations. Should a bidder find discrepancies in, or omissions from the drawings, specifications, or other pre-bid documents, or be in doubt as to their meaning, he shall notify the County at least seven (7) calendar working days prior to the bid opening date. Any and all such interpretations, any supplemental instructions or approval of manufacturer's materials to be substituted will be made only in the form of written addenda to the specifications, which, if issued, will be hand delivered or mailed by certified mail with return receipt requested to all prospective bidders receiving a set of such documents, not later than two (2) calendar days prior to the date fixed for the opening of bids. Failure of any bidder to receive any such addendum or interpretation shall not relieve such bidder from any obligation under his bid as submitted. All addenda so issued are to be covered in the bid for such addenda to become part of the Contract.
18. **Permits and Licenses.** The successful bidder shall be required to have or obtain, at his expense, any and all permits and licenses required by Deschutes County, any City within the County, and the State of Oregon, pertaining to the service he proposes to furnish. Licensing shall include without limitation registration with Construction Contractors Board and in the case of professional engineers and architects proof of current licensing with the appropriate State licensing board.
19. **Minimum Requirements of Bid.** The following minimum requirements as to the form and manner of submitting bids must be strictly observed; variance from these requirements will result in rejection of the bid as unresponsive.
- a. Each Bid must be submitted on forms furnished by the County, and include a complete original set of all forms provided in Part V-Bid Proposal Forms of these Contract Documents.
 - b. Each Bid must be signed by the bidder.
 - c. Bid security, in the required form and amount, must accompany each bid.
 - d. Each blank in the proposal must be filled in unless an alternative is provided. Each separate bid item must be bid on, unless the proposal form clearly indicates otherwise.
 - e. Each Bid must be submitted in a separate sealed envelope, marked to identify without opening, and in the hands of the Solid Waste Department Director at the time and place specified for bid opening.
 - f. A proposal containing modifications, deletions, exceptions or reservations which in any way conflict with or purport to alter any substantive provision contained in the bid documents, will not be considered.
 - g. A conditional bid will not be considered.
 - h. Any bid submitted without all of the pages of Part V-Bid Proposal Forms of these Contract Documents, but with a sufficient number of the pages of the bid documents to allow the evaluation of the bid, shall be deemed to have been submitted with the missing pages for purposes of bid evaluation. The missing pages of the bid documents shall be deemed to be incorporated into bid by reference.
20. **Plans.** Plans are not to be taken or construed as being reproduced at precisely the indicated scale. Where the plans are photographic reductions of the original tracings, the approximate amount of reduction is indicated by a note on the plans.
21. **Specifications.** The specifications are the minimum acceptable specifications for the project for which proposals are sought. Any deviation from the specifications contained herein, shall render the bid non-responsive.

22. **Examination of Site and Conditions.** Bidders are required, prior to submission of bids, to carefully examine the site and the Plans and Specifications of the contemplated work. Errors and omissions in the Plans or Specifications shall be called to the attention of the Solid Waste Department Director prior to submission of bid so that addenda may be issued. Failure to do so on the part of the Contractor does not relieve him of responsibility for a correct and completely finished job. Only a written interpretation or correction by addendum shall be binding.
23. **Pre-Bid Inquiries.** Bidders with pre-bid inquiries shall contact Gerry Friesen of G. Friesen Associates, Inc. at (971) 235-3317 or by e-mail at: gerry@gfriesen.com.
24. **Prequalification of Bidders.** Bidders shall be pre-qualified with the State of Oregon in accordance with ORS 279C.430 and Deschutes County Code 12.52.020. The prequalification class is as shown in the Invitation to Bid. This contract is subject to ORS 279C.800 to 279C.870. The prequalification classification required for this project is "Earthwork and Drainage Construction." The successful bidders and subcontractors providing labor shall maintain a qualified drug-testing program for the duration of the contract. Bidders shall be licensed with the Construction Contractor's Board. Contractors and subcontractors need not be licensed under ORS 468.710.

The County may make any further investigation deemed necessary to resolve any doubt as to the bidder's qualifications, and the bidder shall furnish to the County all such information and data for this purpose as the County may request. The County reserves the right to reject any bid if the evidence submitted or investigation of such bidder fails to satisfy the County that such bidder is in all respects able to adequately perform the obligations of the Contract and to complete the work contemplated therein.

Any bidder who is disqualified may appeal his disqualification to the Board of County Commissioners of Deschutes County, Oregon, which is the local public contract review board as provided by State Law. Written notice of such appeal must be filed with the Board of County Commissioners by the close of business on the third County business day following the bidder's receipt of notice that he is disqualified.

If a bidder has appealed his disqualification within the time provided, but there has been no disposition of the appeal by the Board of County Commissioners, he may submit his sealed bid on a form marked, "SAMPLE ONLY, NOT TO BE USED FOR BIDDING", and sealed in an envelope marked the same. His bid will not be opened, but will be forwarded to the Board of County Commissioners. If after considering the matter, the Board of County Commissioners determines that the bidder is qualified, the Board shall open and read the bid, and it shall be considered with all other bids. If the bidder is not found qualified after appeal, the bid will be opened, copied and returned to the disqualified bidder. The bid shall not be read publicly, and the Board of County Commissioners action on appeal; or its public disclosure is mandated under the procedure as specified in ORS 192.480 or 192.490.

25. **Contract Award.** Deschutes County reserves the right to postpone award of the contract for twenty-one (21) calendar days from the date of the bid opening, or until a final decision is made on a protest, whichever is later.
26. **Bidder Statement.** Submission of a bid for the project shall constitute a statement by the bidder that the provisions of ORS 279C.840 are to be complied with.

Part III
GENERAL CONDITIONS

General Conditions

1. **Prevailing Rates of Wage.** This Contract is subject to the “Prevailing Wage Rates for Public Works Contracts in Oregon” as published by the Oregon Bureau of Labor and Industries (dated July 5, 2023), and, if applicable the Federal Prevailing Rate of Wage required under the Davis-Bacon Act (40 U.S.C. 3141 et seq.) that may be paid to workers in each trade or occupation required for the public works employed in the performance of the contract either by the contractor or subcontractor or other person doing or contracting to do the whole or any part of the work contemplated by the contract. The following internet link may be used to obtain the access to State and Federal Prevailing Wage Rates:

[BOLI Prevailing Wage Rate Book July 5, 2023.pdf \(oregon.gov\)](#)

2. **Required Conditions in Public Works Contract and Contract Specifications - ORS 279C.800 to 279C.870.** County shall pay to the Bureau of Labor and Industries a fee equal to one tenth of one percent (.001) of the contract price but no less than \$250 nor more than \$7,500 regardless of the contract price; that the fee shall be paid no later than the date the contract is signed; and that the fee shall be delivered to the Bureau at the following address: Prevailing Wage Rate Unit, Wage and Hour Division, Bureau of Labor and Industries, 800 NE Oregon Street #32, Portland, OR 97232.

Posting Requirements. Contractors shall post the prevailing wage rates applicable to the project in a conspicuous place at the site of work. The posting shall be easily accessible to employees working on the project.

When a contractor or subcontractor provides for or contributes to a health and welfare plan or pension plan for employees who are working on a public works project, the contractor or subcontractor shall post a notice containing the following information:

- (1) A description of the plan or plans;
- (2) Information on how and where claims can be made; and
- (3) Where to obtain more information .

All required postings shall be posted in the same place and shall be in a conspicuous place at the site of work and shall be easily accessible to employees working on the project.

3. **Required Payroll Submissions.** Contractors and subcontractors on public works projects are required to prepare **weekly** certified payroll reports and statements and submit them to the public contracting agency by the fifth business day of each month. Contractors and subcontractors who fail to submit certified payroll reports as described above, will be subject to a twenty five percent (25%) withholding of the amounts owed by the County.

Information submitted on certified statements may be used only to ensure compliance with the provisions of ORS 279C.800 to 279C.870. These are public records and must be made available on request. Contractors may submit their own report as long as it contains all the same information as the WH-38 form (see Prevailing Wage Rates published by the Oregon Bureau of Labor and Industries for forms). Contractors must complete the statement of certification and attach it to the payroll submissions.

4. **Contracting Agency Payments.** If the Contractor fails, neglects, or refuses to make prompt payment of any claim for labor or services furnished to the Contractor or Subcontractor by any person, or the assignee of the person, in connection with the public works contract as such claim becomes due, the proper officer or officers

of the public contracting agency may pay such claim and charge the amount of the payment against funds due or to become due the Contractor by reason of the Contract.

5. **Interest Rate For Failure to Make Payment.** If Contractor or a first-tier subcontractor fails, neglects or refuses to make payment to a person furnishing labor or materials in connection with this contract for a public improvement within 30 days after receipt of payment from the County or a Contractor, the Contractor or first-tier subcontractor shall owe the person the amount due plus interest charges commencing at the end of the 10-day period that payment is due under ORS 279C.580(4) and ending upon final payment, unless payment is subject to a good faith dispute as defined in ORS 279C.580. The rate of interest charged to the Contractor or first-tier subcontractor on the amount due shall equal three times the discount rate on 90-day commercial paper in effect at the Federal Reserve Bank in the Federal Reserve district that includes Oregon on the date that is 30 days after the date when payment was received from the County or from the Contractor, but the rate of interest shall not exceed 30 percent. The amount of interest may not be waived.
6. **Construction Contractors Board Complaint.** If Contractor or a subcontractor fails, neglects or refuses to make payment to a person furnishing labor or materials in connection with this contract, the person may file a complaint with the Construction Contractors Board, unless payment is subject to a good faith dispute as defined in ORS 279C.580.
7. **Independent Contractor.** Contractor is engaged hereby as an independent contractor, and will be so deemed for purposes of the following:
 - A. Contractor will be solely responsible for payment of any Federal or State taxes required as a result of this Agreement.
 - B. This Contract is not intended to entitle Contractor to any benefits generally granted to County employees. Without limitation, but by way of illustration, the benefits which are not intended to be extended by this Contract to the Contractor are vacation, holiday and sick leave, other leaves with pay, tenure, medical and dental coverage, life and disability insurance, overtime, Social Security, Workers' Compensation, unemployment compensation, or retirement benefits (except insofar as benefits are otherwise required by law if the Contractor is presently a member of the Public Employees Retirement System).
 - C. Contractor is an independent contractor for purposes of the Oregon Workers' Compensation law (ORS Chapter 656) and is solely liable for any Workers' Compensation coverage under this Contract. If Contractor has the assistance of other persons in the performance of this Contract, the Contractor shall qualify and remain qualified for the term of this Contract as a direct responsibility employer under ORS 656.407, and furnish County with evidence of said insurance. If Contractor performs this contract without the assistance of any other person, Contractor shall execute a Joint Declaration with County's Workers' Compensation carrier absolving County of any and all liability from Workers' Compensation provided in ORS 656.029 (2).
8. **Delegation and Reports.** Contractor shall not delegate the responsibility for providing services hereunder to any other individual or agency, and shall provide County with periodic reports to County at the frequency and with the information prescribed to be reported by County.
9. **Constraints.** Pursuant to the requirements of ORS 279C.500 through 279C.540 and Article XI, Section 10, of the Oregon Constitution, the following terms and conditions are made a part of this Agreement:
 - A. Contractor shall:
 - (1) Make payments promptly, as due, to all persons supplying to Contractor labor or materials for the prosecution of the work provided for in this Agreement.

- (2) Pay all contributions or amounts due the Industrial Accident Fund from such contractor or subcontractor incurred in the performance of this Agreement.
 - (3) Not permit any lien or claim to be filed or prosecuted against County on account of any labor or material furnished.
 - (4) Pay to the Department of Revenue all sums withheld from employees pursuant to ORS 316.167.
 - (5) Demonstrate that an employee drug testing program is in place prior to execution of this Contract.
- B. If Contractor fails, neglects or refuses to make prompt payment of any claim for labor or services furnished to Contractor or a subcontractor by any person in connection with this agreement as such claim becomes due, the proper officers representing County may pay such claim to the person furnishing the labor or services and charge the amount of the payment against funds due or to become due Contractor by reason of this agreement.
- C. Employees of Contractor shall be paid at least time and a half or all overtime worked in excess of eight hours a day or forty (40) hours in any one week when the work week is five consecutive days, Monday through Friday; or for all overtime in excess of 10 hours a day or 40 hours in any one week when the work week is four consecutive days, Monday through Friday, except individuals under this contract who are excluded under ORS 653.010 to 653.261 or under 29 U.S.C. Sections 201 to 209 from receiving overtime.
- D. Employees of Contractor providing labor shall be paid at least time and a half for all work performed on Saturday and Sunday and the following legal holidays:
- a) New Year's Day on January 1.
 - b) Memorial Day on the last Monday in May.
 - c) Independence Day on July 4.
 - d) Labor Day on the first Monday in September.
 - e) Thanksgiving Day on the fourth Thursday in November.
 - f) Christmas Day on December 25.
- E. An employer must give notice to employees who perform work under this agreement in writing, either at the time of hire or before commencement of work on the contract, or by posting a notice in a location frequented by employees, of the number of hours per day and days per week that employees may be required to work.
- F. Contractor shall promptly, as due, make payment to any person or partnership, association or corporation furnishing medical, surgical and hospital care or other needed care and attention incident to sickness and/or injury to the employees of Contractor, of all sums which Contractor agrees to pay for such services, and all monies and sums which Contractor collected or deducted from the wages of Contractor's employees pursuant to any law, contract or agreement for the purpose of providing or paying for such services.
- G. This Agreement is expressly subject to the debt limitation of Oregon counties set forth in Article XI, Section 10, of the Oregon Constitution, and is contingent upon funds being appropriated therefore. Any provision herein which would conflict with law are deemed inoperative to that extent.
- H. All subject employers working under this contract are either employers that will comply with ORS 656.017 or are employers that are exempt under ORS 656.126

10. Early Termination. This Contract may be terminated as follows:

- a. Mutual Consent. County and Contractor, by mutual written agreement, may terminate this Contract at any time.

- b. Party's Convenience. County or Contractor may terminate this Contract for any reason upon 30 calendar days written notice to the other party.
- c. For Cause. County may also terminate this Contract effective upon delivery of written notice to the Contractor, or at such later date as may be established by the County, under any of the following conditions:
 - 1) If funding from state or other sources is not obtained and continued at levels sufficient to allow for the purchase of the indicated quantity of services as required in this contract. This Contract may be modified to accommodate the change in available funds.
 - 2) If state laws, regulations or guidelines are modified, changed or interpreted in such a way that the services are no longer allowable or appropriate for purchase under this Contract or are no longer eligible for the funding proposed for payments authorized by this contract.
 - 3) In the event sufficient funds shall not be appropriated for the payment of consideration required to be paid under this contract, and if County has no funds legally available for consideration from other sources.
 - 4) If any license or certificate required by law or regulation to be held by the Contractor to provide the services required by this Contract is for any reason denied, revoked, suspended, not renewed or changed in such a way that the Contractor no longer meets requirements for such license or certificate.
- d. Contractor Default or Breach. The County, by written notice to the Contractor, may immediately terminate the whole or any part of this Contract under any of the following conditions:
 - 1) If the Contractor fails to provide services called for by this Contract within the time specified or any extension thereof.
 - 2) If the Contractor fails to perform any of the other requirements of this Contract or so fails to pursue the work so as to endanger performance of this Contract in accordance with its terms, and after receipt of written notice from the County specifying such failure, the Contractor fails to correct such failure within 10 calendar days or such other period as the County may authorize.
 - 3) Contractor institutes or has instituted against it insolvency, receivership or bankruptcy proceedings, makes an assignment for the benefit of creditors, or ceases doing business on a regular basis.
- e. County Default or Breach. Contractor may terminate this Contract in the event of a breach of this Contract by the County. Prior to such termination, the Contractor shall give to the County written notice of the breach and intent to terminate. If the County has not entirely cured the breach within 10 calendar days of the date of the notice, then the Contractor may terminate this Contract at any time thereafter by giving notice of termination.

11. Payment on Early Termination. Upon termination pursuant to paragraph 10, payment shall be made as follows:

- a. If terminated under subparagraphs 10 a. through c. of this Contract, the County shall pay Contractor for work performed prior to the termination date if such work was performed in accordance with the Contract. County shall not, however, pay Contractor for any obligations or liabilities incurred by Contractor after Contractor receives written notice of termination.
- b. If this Contract is terminated under subparagraph 10 d. of this Contract, County obligations shall be limited to payment for services provided in accordance with this Contract prior to the date of termination, less any damages suffered by the County.
- c. If terminated under subparagraph 10 e of this Contract by the Contractor due to a breach by the County, then the County shall pay the Contractor for work performed prior to the termination date if such work was performed in

accordance with the Contract (a) with respect to services compensable on an hourly basis, for unpaid invoices, hours worked within any limits set forth in this Contract but not yet billed, authorized expenses incurred and interest within the limits set forth under ORS 293.462, and (b) with respect to deliverable-based Work, the sum designated for completing the deliverable multiplied by the percentage of Work completed and accepted by County, less previous amounts paid and any claim(s) that County has against Contractor. In no event shall County be liable to Contractor for any expenses related to termination of this Contract or for anticipated profits.

12. Remedies. In the event of breach of this Contract the parties shall have the following remedies:

- a. Termination under subparagraphs 10 a. through c. of this Contract shall be without prejudice to any obligations or liabilities of either party already reasonably incurred prior to such termination. Contractor may not incur obligations or liabilities after Contractor receives written notice of termination. Additionally, neither party shall be liable for any indirect, incidental, consequential or special damages under this Contract or for any damages of any sort arising solely from the termination of this Contract in accordance with its terms.
- b. If terminated under subparagraph 10 d. of this Contract by the County due to a breach by the Contractor, County may pursue any remedies available at law or in equity. Such remedies may include, but are not limited to, termination of this contract, return of all or a portion of this Contract amount, payment of interest earned on this Contract amount, and declaration of ineligibility for the receipt of future contract awards. Additionally, County may complete the work either itself, by agreement with another Contractor, or by a combination thereof. If the cost of completing the work exceeds the remaining unpaid balance of the total compensation provided under this Contract, then the Contractor shall pay to the County the amount of the reasonable excess.
- c. In addition to the remedies in paragraphs 10 through 12 of this Contract for a breach by the Contractor, the County also shall be entitled to any other equitable and legal remedies that are provided by law.
- d. If previous amounts paid to Contractor exceed the amount due to Contractor under this Contract, Contractor shall repay any excess to County upon demand.
- e. If the County breaches this Contract, Contractor's sole monetary remedy shall be (a) with respect to services compensable on an hourly basis, a claim for unpaid invoices, hours worked within any limits set forth in this Contract but not yet billed, authorized expenses incurred and interest within the limits set forth under ORS 293.462, and (b) with respect to deliverable-based Work, a claim for the sum designated for completing the deliverable multiplied by the percentage of Work completed and accepted by County, less previous amounts paid and any claim(s) that County has against Contractor. In no event shall County be liable to Contractor for any expenses related to termination of this Contract or for anticipated profits.
- f. Neither County nor Contractor shall be held responsible for delay or default caused by fire, civil unrest, labor unrest, riot, acts of God, or war where such cause was beyond reasonable control of County or Contractor, respectively. Contractor shall, however, make all reasonable efforts to remove or eliminate such a cause of delay or default and shall, upon the cessation of the cause, diligently pursue performance of its obligations under this Contract. For any delay in performance as a result of the events described in this subparagraph, Contractor shall be entitled to additional reasonable time for performance that shall be set forth in an amendment to this Contract.
- g. The passage of this Contract expiration date shall not extinguish or prejudice the County's or Contractor's right to enforce this Contract with respect to any default or defect in performance that has not been cured.
- h. LIQUIDATED DAMAGES. It is impractical to determine the actual damages that the County would sustain in the event the project is not completed by June 1, 2024. Therefore, the Contractor shall pay to the County, not as a penalty, but as liquidated damages, **\$1,295.00 per day**, or any portion thereof, for each day in which the project is not completed by such date.

- i. County's remedies are cumulative to the extent the remedies are not inconsistent, and County may pursue any remedy or remedies singly, collectively, successively or in any order whatsoever.
13. **Contractor's Tender Upon Termination.** Upon receiving a notice of termination of this Contract, Contractor shall immediately cease all activities under this Contract unless County expressly directs otherwise in such notice of termination. Upon termination of this Contract, Contractor shall deliver to County all documents, information, works-in-progress and other property that are or would be deliverables had this Contract been completed. Upon County's request, Contractor shall surrender to anyone County designates, all documents, research, objects or other tangible things needed to complete the work.
14. **Work Standard.** Contractor shall be solely responsible for and shall have control over the means, methods, techniques, sequences and procedures of performing the work, subject to the plans and specifications under this Contract and shall be solely responsible for the errors and omissions of its employees, subcontractors and agents. For goods and services to be provided under this contract, Contractor agrees to:
 - a. Perform the work in a good, workmanlike, and timely manner using the schedule, materials, plans and specifications approved by County;
 - b. Complies with all applicable legal requirements;
 - c. Complies with all programs, directives, and instructions of County relating to safety, storage of equipment or materials;
 - d. Take all precautions necessary to protect the safety of all persons at or near County or Contractor's facilities, including employees of Contractor, County and any other contractors or subcontractors and to protect the work and all other property against damage.
15. **Hold Harmless.** To the fullest extent allowed by law Contractor shall indemnify, save harmless and defend the County from and against all claims, suits or actions for damages, costs, losses and expenses arising from Contractor's torts, as the term "tort" is defined in ORS 30.260(8).
16. **Contractor Not An Agent of County.** It is agreed by and between the parties that Contractor is not carrying out a function on behalf of County, and County does not have the right of direction or control of the manner in which Contractor delivers services under this agreement or exercise any control over the activities of Contractor.
17. **Partnership.** County is not, by virtue of this Contract, a partner or joint venturer with Contractor in connection with activities carried out under this Contract, and shall have no obligation with respect to Contractor's debts or any other liabilities of each and every nature.
18. **Insurance.** In conjunction with all services performed under this agreement: Contractor shall furnish proof of the types and amounts of insurance indicated in Part VI, Agreement Forms, attached hereto and by this reference incorporated herein. County reserves the right to require completed, certified copies of all required insurance policies, at any time.
19. **Non-Discrimination.** Contractor agrees that no person shall, on the grounds of race, color, creed, national origin, sex, marital status, or age, suffer discrimination in the performance of this Agreement when employed by Contractor. Contractor agrees to comply with Title VI of the Civil Rights Act of 1964, with Section V of the Rehabilitation Act of 1973, and with all applicable requirements of federal and state civil rights and rehabilitation statutes, rules and regulations. Additionally, each party shall comply with the Americans with Disabilities Act of 1990 (Pub. L. No. 101-336), ORS 659A.112, and all regulations and administrative rules established pursuant to those laws.

20. **Non-Appropriation.** In the event sufficient funds shall not be appropriated for the payment of consideration required to be paid under the Contract, and if County has no funds legally available for consideration from other sources, then County may terminate this agreement in accordance with Paragraph 10 of these General Conditions.
21. **Attorney Fees.** In the event an action, lawsuit or proceeding, including appeal there from, is brought for failure to observe any of the terms of this Agreement, each party shall be responsible for their own attorney's fees, expenses, costs and disbursements for said action, suit, proceeding or appeal.
22. **Claim, Action, Suit or Proceeding.** This Contract shall be governed by and construed in accordance with the laws of the State of Oregon without regard to principles of conflicts of law. Any claim, action, suit or proceeding (collectively, "Claim") between County and Contractor that arises from or relates to this Contract shall be brought and conducted solely and exclusively within the Circuit Court of Deschutes County for the State of Oregon; provided, however, if a Claim must be brought in a federal forum, then it shall be brought and conducted solely and exclusively within the United States District Court for the District of Oregon. THE RECIPIENT, BY EXECUTION OF THIS CONTRACT, HEREBY CONSENTS TO THE IN PERSONAM JURISDICTION OF SAID COURTS.
23. **Land Use Permit.** This contract does not constitute a land use permit, nor does acceptance of this Contract by Contractor constitute approval of any legislative or quasi-judicial action required as a condition precedent to use of the land for the intended purpose.
24. **Drug Testing Program.** The drug testing program in place at execution of this Contract shall remain in place for the duration of the Contract.
25. **Records Maintenance; Right to Audit Records.**
- A. Records Maintenance; Access. Contractors and subcontractors shall maintain all fiscal records relating to Contracts in accordance with generally accepted accounting principles ("GAAP"). In addition, Contractors and subcontractors shall maintain all other records necessary to clearly document.
 - B.
 - C.
 - 1) Their performance; and
 - 2) Any claims arising from or relating to their performance under this Contract. Contractors and subcontractors shall make all records pertaining to their performance and any claims under a Contract (the books, fiscal records and all other records, hereafter referred to as "Records") accessible to the County at reasonable times and places, whether or not litigation has been filed as to such claims.
 - D.
 - E. Inspection and Audit. County may, at reasonable times and places, have access to and an opportunity to inspect, examine, copy, and audit the Records of any Entity that has submitted cost or pricing data according to the terms of a Contract to the extent that the Records relate to such cost or pricing data. If the Entity must provide cost or pricing data under a Contract, the Entity shall maintain such records that relate to the cost or pricing data for 3 years from the date of final payment under the Contract, unless a shorter period is otherwise authorized in writing.
 - F.
 - G. Records Inspection and Control Audit. County, and its authorized representatives, shall be entitled to inspect, examine, copy, and audit any Contractor's or subcontractor's Records, as provided in Section A of this rule. The Contractor and subcontractor shall maintain the Records and keep the Records accessible and available at reasonable times and places for a minimum period of 3 years from the date of final payment under the Contract or subcontract, as applicable, or until the conclusion of any audit, controversy or litigation arising out of or related to the Contract, whichever date is later, unless a shorter period is otherwise authorized in writing.
 - H.
26. **Contract Rules.** The rules applicable to this contract are the Attorney General's Model Public Contract Rules, Chapter 137-046 and Chapter 137-049, as presently constituted and Deschutes County Code (DCC) Chapter

2.37. The provisions of DCC Chapter 2.37.150 are incorporated herein by reference. These provisions may be viewed at the following web address: <http://www.co.deschutes.or.us/dccode/Title2/docs/Chapter%202.37doc>

27. **Contractor Certifies.** By execution of this contract, Contractor certifies, under penalty of perjury, that:
- A. To the best of Contractor's knowledge, Contractor is not in violation of any tax laws described in ORS 305.380(4), and
 - B. Contractor has not discriminated against minority, women or small business enterprises in obtaining any required subcontracts.
28. **Contract Provisions.** Contractor shall make all provisions of this contract with the County applicable to any subcontractor performing work under the contract.
29. **Contract Content.** This Contract and attached exhibits and attachments constitute the entire agreement between the parties on the subject matter hereof. There are no understandings, agreements, or representations, oral or written, not specified herein regarding this Contract. No waiver, consent, modification or change of terms of this Contract shall bind either party unless in writing and signed by both parties and all necessary County approvals have been obtained. Such waiver, consent, modification or change, if made, shall be effective only in the specific instance and for the specific purpose given. The failure of the County to enforce any provision of this Contract shall not constitute a waiver by County of that or any other provision.
30. **Hazardous Materials.** Contractor shall not generate, store, process, dispose, release or discharge into the environment any hazardous, toxic, radioactive, or other dangerous materials on or about the work site subject to this Contract, nor allow any of its subcontractors to engage in such prohibited activities. Contractor agrees to indemnify, defend and hold the County, its officer, agents, and employees harmless from and against any and all claims, suits, actions, demands, damages, costs, losses and expenses in any manner resulting from, arising out of, or connected with any such prohibited activities of Contractor or its subcontractors. Discovery by Contractor of unanticipated hazardous, toxic, radioactive or other dangerous materials present at the work site shall not constitute a release or discharge by Contractor.
- County and Contractor agree that, Contractor's discovery of unanticipated hazardous, toxic, radioactive, or other dangerous materials constitutes a changed condition mandating re-negotiation of the scope of work to be performed by Contractor, the terms under which the work is to be performed, and the charges therefore. Except as otherwise specified in this paragraph, nothing contained in this Contract shall be construed or interpreted as requiring Contractor to assume the status of an owner, operator, or generator, under any federal or state statute governing the disposal, transportation, storage or treatment of hazardous substances or wastes. Contractor shall not directly or indirectly assume title to such hazardous or toxic substances. Should the proper and lawful transportation and disposal of any such materials be required, Contractor's responsibilities shall be limited to facilitating the preparation of manifests or related documents for execution by County for the proper disposal, storage or treatment of such materials. In the event such materials are discovered at the work sites by County, Contractor or any of their employees, subcontractors or agents, County shall have the option to terminate this Contract pursuant to paragraph 10 herein. Contractor shall have an affirmative duty to disclose and immediately notify County upon discovery or knowledge of the existence of any such materials at the work site.

PART IV
SPECIAL PROVISIONS

Knott Landfill – Cell 9 Construction Project Special Provisions

Table of Contents

DIVISION 1: GENERAL REQUIREMENTS	1
SECTION 01010 - SUMMARY OF THE WORK	1
SECTION 01040 - TECHNICAL SPECIFICATIONS	2
SECTION 01042 - RESTORATION OF SURFACES	2
SECTION 01045 - COOPERATION WITH COUNTY AND OTHER CONTRACTORS	3
SECTION 01050 - SURVEYING	3
SECTION 01060 - CODES, PERMITS AND PREVENTION OF ENVIRONMENTAL DEGRADATION.....	4
SECTION 01070 - SAFETY PROVISIONS.....	5
SECTION 01100 - TEMPORARY WATER POLLUTION/EROSION.....	8
SECTION 01150 - MEASUREMENT, PAYMENT AND RETAINED AMOUNTS.....	9
SECTION 01210 - CONSTRUCTION SCHEDULE	9
SECTION 01220 - PROGRESS MEETINGS	10
SECTION 01230 - PRECONSTRUCTION CONFERENCE	11
SECTION 01340 - SHOP DRAWINGS, PRODUCT DATA AND SAMPLES.....	11
SECTION 01370 - SCHEDULE OF VALUES	13
SECTION 01400 - QUALITY CONTROL	13
SECTION 01510 - MAINTENANCE OF EXISTING FACILITIES AND CONTRACTOR COORDINATION.....	13
SECTION 01530 - TEMPORARY FACILITIES, UTILITIES.....	14
SECTION 01540 - SPECIAL CONTROLS.....	14
SECTION 01570 - TRAFFIC MAINTENANCE AND PROTECTION	15
SECTION 01700 - PROJECT CLOSEOUT	15
SECTION 01710 - CONTRACT CLOSEOUT PROCEDURE.....	16
SECTION 01802 - RATE OF WAGES FOR LABORERS AND MECHANICS	18
SECTION 01803 - PAYROLLS AND PAYROLL RECORDS.....	19
SECTION 01804 - TERMINATION OF WORK ON FAILURE TO PAY AGREED WAGES AND COMPLETION OF WORK	19
DIVISION 2: SITE WORK	21
SECTION 02010 - SITE CONDITIONS	21
SECTION 02020 - QUALITY CONTROL TESTING.....	21
SECTION 02100 - MOBILIZATION	22
SECTION 02110 – INTERFACE FRICTION ANGLE TESTING	23
SECTION 02150 - CLEARING AND GRUBBING	24
SECTION 02200 - EXCAVATION AND EMBANKMENT	24
SECTION 02250 – DRILLING AND BLASTING	27
SECTION 02300 - CUSHIONING LAYER	27
SECTION 02301 – DRAINAGE LAYER.....	28
SECTION 02302 – BASE COURSE	30
SECTION 02303 – AGGREGATE IN STOCKPILE	31
SECTION 02306 – HOT MIXED ASPHALT CONCRETE (HMAC)	32

SECTION 02311 - GEOSYNTHETIC CLAY LINER..... 33

SECTION 02312 - GEOMEMBRANE..... 38

SECTION 02313 - GEOTEXTILE 50

SECTION 02314 – GEONET COMPOSITE 56

SECTION 02410- LANDFILL GAS COLLECTION SYSTEM 61

SECTION 02624 - LEACHATE COLLECTION SYSTEM PIPING 67

SECTION 02635 - BOLLARDS 69

SECTION 02636 – WATER TRUCK FILLING STATION 69

SECTION 02638 – CHAIN LINK FENCE AND GATES..... 71

Knott Landfill – Cell 9 Construction Project Special Provisions

The engineering material and data contained in these Special Provisions was prepared under the supervision and direction of the undersigned, whose seal as an Oregon registered Professional Engineer is affixed below.



Renews: 12/31/2023

G. Friesen Associates, Inc.
Gerald Friesen, P.E.
Principal Engineer

Division 1: General Requirements

Section 01010 - Summary of the Work

- A. General Statement and Extent of Work.** The work to be performed under these Contract Documents consists of furnishing all labor, materials, tools, and equipment necessary for the construction of the Knott Landfill - Cell 9 Construction Project. The project site is at the intersection of SE 27th and Rickard Road in Deschutes County, Oregon. Project location maps are shown on the Drawings.

The work shall be performed in a workmanlike manner, complete and usable as required by the Drawings and these specifications. The work is to be constructed for Deschutes County, herein defined as the Owner.

The general work to be performed for the Knott Landfill Cell 9 Construction Project includes, but is not limited to, the following major items:

- Excavation for refuse cell and construction of embankments;
- Installation of geosynthetic clay liner (GCL), high-density polyethylene (HDPE) geomembrane, geotextile and geonet composite;
- Installation of soil materials for purposes of cushioning, drainage, and protection as part of the liner system and quality control testing of same;
- Construction of leachate collection and removal systems (LCRS);
- Installation of landfill gas (LFG) piping systems;
- Relocation of the existing water truck loading station; and
- Installation of chain link fence.

- B. Drawings for Construction.** Detailed drawings for this project are shown on the contract drawings which bear the general title:

**Contract Drawings for the
Knott Landfill - Cell 9 Construction Project
Deschutes County, Oregon**

- C. Time of Completion and Liquidated Damages.** Performance of the work to be done under the Contract shall be commenced within ten (10) calendar days after receipt of written notice to proceed by the Contractor, unless later commencement of the work is authorized by the Engineer. The Contractor shall complete all work items on or before June 1, 2024. For each calendar day after this date that the work remains uncompleted, the Contractor shall pay to the Owner one thousand two hundred and ninety five dollars (\$1,295) per calendar day as liquidated damages.

Such amounts shall be a reimbursement to the Owner for damages which the Owner will have sustained by reason of such delayed completion. Damages so liquidated are understood to include the additional cost to the Owner for interference with landfilling operations, engineering supervision, observation of construction, interest charges and overhead.

- D. Excess Work Hours.** If the Contractor wishes to work at such a time of the day which is during the period other than the regular business hours of the County, including at night, between the hours of 5:00 pm and 7:00 am, or on a Saturday, Sunday, or legal State holiday, he shall make a written request for authorization to conduct excess work hour operations and construction monitoring services during such period. If such a request is made and granted, the Contractor shall notify the Engineer not less than twenty-four (24) hours in advance of the time when such monitoring services are required.

- E. **Project Coordination.** It shall be the responsibility of the Contractor to coordinate all work to be performed under this Contract. This coordination shall encompass all work to be performed by the Contractor, Contractor's subcontractors, the Owner, and any public utilities which may be involved.
- F. **Access to the Work.** The Contractor shall provide access to the work as may be required by the Owner or Engineer. The Contractor also shall provide access to the work for representatives of local, state, and federal agencies as may be required for inspection of the progress of the work, the methods of construction, and for any other aspect of the work or the Contractor's operation under the jurisdiction of the respective agency.

Section 01040 - Technical Specifications

- A. **General Statement.** Articles, materials, operations or methods mentioned in these Special Provisions, or indicated on the Drawings as being required for the project, shall be provided by the Contractor, and Contractor shall provide each item mentioned or indicated, perform according to the conditions stated in each operation prescribed, and provide, therefore, all necessary labor, equipment, and incidentals necessary to make a complete and operable installation.

No attempt has been made in these Contract Documents to segregate work covered by any trade or subcontract under one specification. Such segregation and establishment of subcontract limits will be solely a matter of specific agreement between the Contractor and Contractor's subcontractors. The Contractor and subcontractor in each case is cautioned that work included in any subcontract may be divided between several general specifications, and that each general specification or subheading of the Special Provisions may include work covered by two or more subcontracts or work in excess of any one subcontract.

- B. **Standard Specifications.** The "Oregon Standard Specifications for Construction", 2021 Edition, prepared by the Oregon Department of Transportation and amendments thereto are hereby made a part of this Contract Document and shall be the "Oregon Standard Specifications". The Oregon Standard Specifications requirements for measurement and payment are not applicable to this project.

Should a conflict occur between the General and Special Provisions as contained herein and those of the Oregon Standard Specifications, the General and Special Provisions shall have precedence.

Where the term "Commission", "Department", "Division", or "Oregon Transportation Commission" appears in the Oregon Standard Specifications, it shall be interpreted to mean the Deschutes County Solid Waste Department.

Where the term "Engineer" appears in the Oregon Standard Specifications, it shall be interpreted to mean G. Friesen Associates, Inc. (GFA) directly or acting through its duly authorized representatives.

Where the term "State" appears in the Oregon Standard Specifications, it shall be interpreted to mean Deschutes County acting through authorized representatives.

Section 01042 - Restoration of Surfaces

- A. **Roads and Streets.** The Contractor shall restore all roads and streets in which the surface is removed, broken or damaged, or in which the ground has caved or settled, due to the performance of work covered by this Contract, to the original grade and cross section unless otherwise indicated. The Contractor shall match the existing surfacing for depth, materials and surface finish, including striping and pavement markings, except as otherwise specified.
- B. **Curbs, Gutters, Driveways and Sidewalks.** The Contractor shall reconstruct all curbs, gutters, driveways, sidewalks and similar structures which are broken or damaged during construction. The Contractor shall reconstruct with the same kind of material with the same finish, and in not less than the same dimensions as the original work. The Contractor shall remove and replace the entire portions between joints or scores and not merely

by refinishing the damaged part. The Contractor shall match the appearance of the existing improvements as nearly as possible, except as otherwise required.

- C. Cultivated Areas and Other Surfaces.** The Contractor shall restore all cultivated areas, which are damaged by actions of the Contractor, to their original condition. The Contractor shall remove ornamental trees and shrubbery with earth surrounding the roots wrapped in burlap, and replant in their original positions, or, as an alternative, replace with equal material.

For lawn areas, the Contractor shall cut the sod, roll and replace after the excavation has been properly compacted. Or, as an alternative, cover the excavated area with top soil to the depth of the original top soil and reseed, water and maintain as directed. The Contractor shall notify the owner of any private property prior to construction upon their premises.

The materials storage areas shall be restored to their original condition by the Contractor at the conclusion of the project. The Contractor shall match the existing surfacing for depth, materials and surface finish, except as otherwise specified.

- D. Measurement and Payment.** No separate or additional payment will be made for Restoration of Surfaces, but shall be considered incidental to the work and shall be included in various unit or lump sum bid items.

Section 01045 - Cooperation with County and Other Contractors

The County will be operating the existing Knott Landfill during construction of the Knott Landfill Cell 9 Improvements. The Contractor will not be allowed to work in the active areas of the site being used for refuse disposal which are located to the west of Cell 9. The Contractor must not restrict access for the Owner and public to those areas of the landfill being used for refuse disposal. The Contractor shall construct and maintain detour routes approved by the Owner to these areas of the landfill as necessary for Contractor's convenience, at no additional cost to the Owner. The Contractor shall submit shop drawing(s) showing proposed detour route including traffic control in accordance with Section 01340.

The Contractor shall extend full cooperation to the County, other contractors, and the public. The Contractor shall schedule and construct his work in conjunction with these and other organizations to minimize mutual interference.

No separate or additional payment will be made for cooperation with the County, the public, and other contractors, but shall be considered incidental to the work and shall be included in various unit or lump sum bid items.

Section 01050 - Surveying

- A. General.** The Contractor shall verify all grades, lines, levels and dimensions shown on the Drawings and shall report any errors or inconsistencies to the Engineer before commencing work. Failure to do so shall make the Contractor responsible for any changes which may be required thereafter in connection therewith. The Contractor shall, at Contractor's expense, furnish all stakes, templates, platforms, equipment, and labor that may be required in setting or laying out any part of the work.

The Contractor will be held responsible for the proper execution of the work to such lines and grades as shown on the Drawings and as may be directed by the Engineer. All stakes or other marks thus established shall be preserved by Contractor until their removal is authorized by the Engineer.

The Drawings show approximate elevations as of June 30, 2023. Additional areas have been excavated and filled by the Owner or other contractors operating on the site since June 30, 2023. Five survey control (horizontal and vertical) points have been established in the field and are shown in the drawings. Note that the horizontal and vertical positions were determined using RTK GPS methods.

Survey control and Drawings are referenced to the Central Oregon Coordinate System prepared by the Deschutes County Surveyor's Office. Projection parameters are on file at said office. The project datum is: Horizontal NAD (83-91), Vertical NGVD 29. Project units are in International Feet.

The Contractor shall place control stakes on each side of, and beyond the limits of the proposed excavation or embankment and wherever needed.

John Thompson Associates (JTA) has been contracted for directly by the County and is responsible for providing surveying for the following major items of work:

1. *Existing Ground Survey.* Prior to the start of clearing and grubbing, excavation or placement of embankment material, JTA will map all areas where work is to be performed. The northing, easting and elevation of points at grade breaks and at intervals not to exceed 50 feet shall be determined. A digital terrain model (DTM) will be prepared to accurately depict a one-foot contour interval. A topographic map showing both the existing grade and proposed depth of excavation or fill will be sent digitally by the Engineer as an AutoCAD data file and drawing to the Contractor for review. The drawing will show the projected excavation and embankment quantities. No work shall begin until after the Contractor has favorably reviewed the Existing Ground Survey DTM.
2. *Earthwork Survey.* After earthwork has been completed and prior to placement of any overlying material, JTA will map the Cell 9 area. A digital terrain model (DTM) will be prepared to accurately depict a one-foot contour interval. A topographic map showing both the existing grade and proposed depth of excavation or fill will be sent digitally by the Engineer as an AutoCAD data file and drawing to the Contractor for review. The drawing will show the actual excavation and embankment quantities.
3. *Final As-Built Survey.* After work has been completed, JTA will survey the final ground surface within Cell 9. A digital terrain model (DTM) will be prepared to accurately depict a one-foot contour interval. Topography (displayed at a contour interval of 2-feet), piping, equipment, and liner system perimeter will be shown on an AutoCAD data file. The survey will include limits, contours, and grade breaks of drainage aggregate layer and thickness verification at 50-foot grid points (x,y,z). The survey will also include determination of the coordinates for any piping and equipment that was installed and the perimeter of the liner system.

The Contractor shall be responsible for coordination with JTA and shall notify JTA at least 24 hours prior to when surveying for any of the above items is needed.

The surveying performed by JTA will be performed under the supervision of a land surveyor licensed in the State of Oregon.

- B. Measurement and Payment.** No separate or additional payment will be made for surveys or coordination with JTA, but shall be considered incidental to the work and shall be included in the various unit or lump sum bid items.

Section 01060 - Codes, Permits and Prevention of Environmental Degradation

- A. General.** Environmental pollution control shall consist of the protection of the environment from pollution during and as a result of construction operations under the Contract. The control of environmental pollution requires the consideration of air, water and land and involves noise, dust, and other pollutants. It is the responsibility of the Contractor to investigate and comply with all applicable federal, state, and county laws and regulations concerning environmental pollution control and abatement.
- B. Protection of Land Resources.** Land resources within the project area and outside the limits of permanent work performed under the Contract shall be preserved in their present condition or be restored to a natural condition that will not detract from the appearance of the surrounding area. Except in areas marked on the Drawings to be

cleared, the Contractor shall not deface, injure or destroy trees or shrubs nor remove or cut them without approval by the Owner. Any tree or other landscape feature scarred or damaged by the Contractor's equipment or operation shall be restored as nearly as possible to its original condition at the Contractor's expense.

- C. Water Pollution.** The Contractor shall not pollute water resources, including streams and drainage systems, with fuel, oils, bituminous materials, calcium chloride, acids, construction wastes, wash waters or other harmful materials. Surface drainage from cuts and fills, whether or not completed, and from borrow and waste disposal areas, shall, if turbidity-producing materials are present, be held in suitable sedimentation ponds or shall be graded to control erosion to meet acceptable limits. Objectionable construction discharges shall be processed, filtered, ponded or otherwise treated prior to their discharge into a waterway or drainage system. Disposal of any material, garbage, oil, grease, chemicals, trash and other similar materials in areas adjacent to streams or drainage systems is prohibited.
- D. Protection of Fish and Wildlife.** The Contractor shall at all times perform all work and take such steps to prevent any interference or disturbance to fish and wildlife.
- E. Permits.** Contractor shall be responsible for obtaining all permits necessary for completing the work.
- F. Dust Control.** The Contractor shall maintain all excavation, embankment, stockpile and all other work within or adjoining the project site free from dust which would cause a hazard or nuisance. Sprinkling, chemical treatment, bituminous treatment or similar methods will be necessary to control dust. Sprinkling must be repeated at such intervals as to keep all pavements and disturbed areas at least damp enough to prevent dust nuisance at all times, and the Contractor shall have suitable and sufficient equipment on the job to accomplish this work.

Before any work commences under this Contract, the Contractor shall submit to the Engineer, for review, a dust control plan to be enforced for the duration of the project. The plan will outline and describe the steps which will be taken to prevent abnormal dust conditions from being caused by Contractor operations, including operations on any unpaved road, excavation or fill area.

Water is available from Avion Water Company using on-site fire hydrants. If Contractor elects to use this water source, Contractor shall procure a hydrant meter from Avion Water Company and pay any and all fees related to hydrant meter rental and water usage.

- G. Subcontractors.** Compliance with the provisions of this section by the subcontractors will be the responsibility of the Contractor.
- H. Non-Compliance.** The Engineer will notify the Contractor of any non-compliance with the foregoing provisions and the action to be taken. If the Contractor fails or refuses to comply promptly, the Engineer, with the approval of the Owner, may issue an order stopping all or part of the work until satisfactory corrective action has been taken. No extension of time or payment for excess costs or damage shall be made to the Contractor for the time lost due to such stop action. Failure to notify does not change the requirements.
- I. Measurement and Payment.** No separate or additional payment will be made for codes, permits and prevention of environmental degradation, but shall be considered incidental to the work and shall be included in various unit or lump sum bid items.

Section 01070 - Safety Provisions

- A. General.** Contractor shall comply with all health and safety rules, regulations, and ordinances promulgated by the local, state, and federal governments, the various construction permits, and other sections of the Contract Documents. Such compliance shall include, but not be specifically limited to, any and all protective devices, guards, restraints, locks, latches, switches, and other safety provisions that may be required or necessitated by state and federal safety regulations. The Contractor shall determine the specific requirements for safety provisions and

shall cause inspections and reports by the appropriate safety authorities to be conducted to insure compliance with the intent of the regulations.

Contractor shall inform employees and subcontractors and their employees of the potential danger of working on and near landfills.

Contractor shall perform whatever work is necessary for safety and be solely and completely responsible for conditions of the job site, including safety of all persons (including employees of the Owner, Engineer, and Contractor) and property during the contract period. This requirement applies continuously and is not limited to normal working hours.

The Engineer's review of the Contractor's performance does not include a review or approval of the adequacy of the Contractor's safety supervisor, the safety program or any safety measures taken in, on, or near the construction site.

Contractor shall provide for the protection of employees and others from fire, explosion, or asphyxiation caused by any gases encountered during construction and landfill leachate emitted from, and present within, the existing solid waste landfill. Contractor shall provide at all times proper facilities for safe access to the work by authorized government officials.

Accidents causing death, injuries, or damage must be reported to the Engineer immediately in person or by telephone or messenger. In addition, Contractor shall promptly report in writing to the Engineer all accidents whatsoever arising out of, or in connection with, the performance of the work whether on, or adjacent to, the site, giving full details and statements of witnesses.

If a claim is made by anyone against the Contractor or any subcontractor on account of any accident, the Contractor shall promptly report the facts in writing within twenty-four (24) hours after occurrence, to the Engineer, giving full details of the claim.

- B. Warning.** The Contractor is advised that portions of the work for the Knott Landfill Cell 9 Construction Project will be performed over and possibly in buried wastes and refuse. These buried materials decompose in the landfill, generating landfill gas typically composed of carbon dioxide (CO₂), methane (CH₄), hydrogen sulfide (H₂S), and other gases dependent on the composition of the buried materials. These gases may migrate laterally away from the landfill or vent through the landfill surface.

Some of the hazards associated with construction in landfill areas include, but are not limited to:

1. Fires which may start spontaneously from exposed or decomposing refuse.
2. Fires or explosions which may occur from the presence of methane gas.
3. Landfill gases which may cause an oxygen deficiency in trenches, borings, manholes, catch basins, and other structures.
4. Landfill gases that may cause acute toxic effects (e.g., H₂S).
5. Possible caving of trenches and excavations when working over or in refuse fills.
6. Biological pathogens or other vectors.

The Contractor is entirely responsible for the health and safety of all personnel on the project site.

- C. Site Safety and Health Plan.** The Contractor shall develop and maintain for the duration of this Contract, a site safety and health plan that will effectively incorporate and implement all required county, state, and federal safety provisions. Contractor shall provide a written site safety and health plan for the construction within ten (10) calendar days after receiving a Notice to Proceed and prior to commencing work on this project. Contractor shall maintain at least one copy of the plan at the work site. Contractor shall assign an individual serving as a Site Safety and Health Officer at the job site at all times during work who is responsible and authorized to supervise and enforce compliance with the site safety and health plan. In addition to the other items that shall be addressed, the site safety and health plan shall list the appropriate procedures to be followed in the event that hazardous wastes are encountered.

Preparation of the written site safety and health plan is the Contractor's responsibility, and no statement made in these provisions relieves the Contractor of responsibility for information included in, and implementation of, the site safety and health plan.

The Contractor's written site safety and health plan should include, but not be limited to:

1. A list of chemical and physical hazards (such as methane exposure and electrical shock), allowable OSHA exposure levels, threshold limit values, other regulatory exposure levels, and the emergency response should an exposure or injury occur.
2. An emergency evacuation plan for immediate removal to a hospital or a doctor's care any person who may be injured on the job site including evacuation plan routes to medical treatment, and emergency telephone numbers including hospital, ambulance, fire, sheriff/police, poison control, the Engineer, and others as deemed necessary.
3. A list of safety and monitoring equipment at the job site and locations where equipment is stored or expected to be maintained.
4. Monitoring equipment action levels, frequency of testing, and recommended responses.
5. Procedures for entering confined spaces.
6. Procedures to be followed if hazardous waste is encountered.

The Contractor shall inform all workers and the public visiting the site of the potential for the presence of methane and other landfill gases emanating from the natural decomposition of refuse buried at or near the job site and the importance of safety precautions to ensure the safety of workers and the public. The Contractor shall instruct all workers and maintain strict control of construction activity to protect and maintain the integrity of the closed portion of the landfill.

The Contractor shall submit copies of the site safety and health plan in accordance with Section 01340 of the Special Provisions. Failure on the part of the Contractor to follow the site safety and health plan or failure to work in a safe manner may result in suspension of the work by the Owner. The Contractor shall not be entitled to extra compensation for health- and safety-related suspensions, nor shall the Contract completion date be extended.

- E. Contractor Safety Equipment.** As part of the safety program, the Contractor shall maintain at the job site safety equipment applicable to the work as prescribed by the governing safety authorities and all articles necessary for giving first aid to the injured.

The Contractor shall train all personnel in use of the appropriate safety equipment that would be utilized during the course of their work. It is the responsibility of the Site Safety and Health Officer to ascertain that all safety equipment is properly maintained and being used when appropriate.

- F. Site Safety and Health Officer.** The Contractor shall provide a person designated as the Site Safety and Health Officer who is thoroughly trained in rescue procedures and the use of safety equipment and gas detectors. The person must be present at all times while work is being performed, and implement the written site safety and health plan and conduct testing, as necessary.

The Contractor shall provide the Site Safety and Health Officer with the delegated authority to order any person or worker on the landfill site to follow the safety rules. Failure to observe these rules is sufficient cause for removal of the person or worker(s) from this project.

The Site Safety and Health Officer is responsible for determining the extent to which any safety equipment must be utilized, depending on conditions encountered at the site.

- G. Measurement and Payment.** No separate or additional payment will be made for safety provisions, but shall be considered incidental to the work and shall be included in various unit or lump sum bid items.

Section 01100 - Temporary Water Pollution/Erosion

- A. General.** The Contractor is required to prevent, control, and stop water pollution or erosion within the project, thereby protecting the work, nearby land, streams, and other bodies of water.

Controlling pollution, erosion, runoff, and related damage may require the Contractor to perform temporary work items including but not limited to:

1. Providing ditches, berms, culverts, and other measures to control surface water;
2. Building dams, settling basins, energy dissipaters, and other measures to control downstream flows;
3. Controlling underground water found during construction; or
4. Covering or otherwise protecting slopes until permanent erosion-control measures are working.

To the degree possible, the Contractor shall coordinate this temporary work with permanent drainage and erosion control work the Contract requires.

If the Owner orders the work suspended for an extended time, the Contractor shall make every effort to control erosion, pollution, and runoff during shutdown.

If natural elements rut or erode the slope, the Contractor shall restore and repair the damage, with the eroded material where possible, and clean up any remaining material in ditches and culverts. The Contractor shall bear all costs of repairing erosion damage.

The Engineer may require temporary control measures if it appears pollution or erosion may result from weather, the nature of the materials, or progress on the work. The Engineer may also require permanent erosion control work to be done with or immediately after grading.

When temporary control devices are no longer needed, the Contractor shall remove them and finish the areas they occupied as the Engineer directs.

Nothing in this Section shall relieve the Contractor from complying with other Contract requirements.

The Contractor shall bear full responsibility for temporary water pollution/erosion control in all sources of material, disposal sites, and haul roads the Contractor provides.

- B. Measurement and Payment.** No separate or additional payment will be made for preparing and implementing the dust control plans and for implementing any water pollution/erosion control measures expressly described and/or implied above, including all labor, materials, and equipment required to execute the plans, but shall be included in the various contract unit and lump sum bid prices.

Section 01150 - Measurement, Payment and Retained Amounts

- A. Existing Topography and Earth Work Computations.** The Contractor shall satisfy himself as to the current existing site conditions. The Cell 9 area will be surveyed by the County's Surveyor (John Thompson Associates (JTA)) prior to the start of any earthwork and after earthwork has been completed. Digital Terrain Models (DTMs) that are utilized for earthwork computations will be sent by the Engineer to the Contractor for review.
- B. Measurement and Payment - General.** Measurement of pay items will be performed by the Engineer and the Contractor according to the United States standard measures and based upon actual units of work performed or installed. The method of measurement is described under each bid item. Each lump sum bid item has a measurement section in them stating that measurement will be by the lump sum.

Payment will be in accordance with the unit or lump sum prices shown on the Bid Schedule shown in the Proposal. The unit or lump sum contract prices shall constitute full compensation for each bid item including all costs for overhead, profit, fees, taxes, bonding, insurance, and for furnishing all plant, materials, labor, equipment, tools, and performing all operations required as well as all work incident or incidental to complete the work in accordance with the Contract Documents, and to provide operation and maintenance manuals, guarantees and warranties as well as as-built documentation of the completed work.

In the event that terms for "measurement and payment" and/or "measurement" and/or "payment" are not directly mentioned in a section, such omission shall be construed to mean that no separate or additional payment will be made for the work described in that section, but shall be considered incidental and included in various unit or lump sum bid items.

- C. Retained Amount (Retainage).** The amount to be retained from progress payments to protect the County's interests shall be 2.5 percent of the value of work accomplished, and shall be withheld as described in Section 00195.50 of the Oregon Standard Specifications.

Section 01210 - Construction Schedule

- A. Construction Schedule.** Within ten (10) calendar days after Notice to Proceed, or such later time as may be designated by the Engineer, the Contractor shall prepare and submit to the Engineer for review a construction schedule, showing the order in which the Contractor proposes to carry on the work, the dates on which salient features will be started (including the procurement of materials, plant and equipment) and the contemplated dates for completing the same. No payment for mobilization will be made until receipt of the construction schedule by the Engineer.

The Contractor shall prepare and submit a construction schedule in the form of a Gantt Chart. The project's critical path, along with the start and end dates of each of the individual work items shall be shown. The construction schedule shall be in sufficient detail that progress of the work can be evaluated accurately at any time during the performance of the Contract.

The construction schedule shall be updated monthly. The Owner will make no progress payments under this Contract until an updated construction schedule has been submitted for review.

All costs associated with the submittal of the construction schedule updates shall be incidental to and included in the various contract items.

Review of any schedule submitted by the Contractor shall not be construed to assign responsibility of performance or contingencies to the Engineer or relieve the Contractor of responsibility to adjust forces, equipment, and work schedules as may be necessary to ensure completion of the work within the prescribed contract time.

- B. Revisions.** If, in the opinion of the Engineer, the Contractor's work activities are inconsistent with the order, sequence, or timing of the activities shown on the construction schedule, the Engineer may require the Contractor to propose methods, such as providing additional equipment and/or workers, to complete the work within the specified time limit. The Engineer may require the Contractor to submit supplementary construction schedules demonstrating the agreed rate of progress and the order and sequence of the work.
- C. Failure to Comply.** Failure of the Contractor to comply with the requirements of the Engineer under the provisions of this section shall be grounds for determination by the Engineer that the Contractor is not prosecuting the work with such diligence as will insure completion within the time specified. Upon such determination, the Owner may terminate the Contractor's right to proceed with the work, or any separable part thereof, in accordance with determination for default or in accordance with other provisions provided in the Contract Documents.
- D. Payment.** No separate or additional payment will be made for the construction schedule, but shall be considered incidental to the work and shall be included in various unit or lump sum bid items.

Section 01220 - Progress Meetings

- A. General.** The Engineer and Contractor shall arrange for and conduct progress meetings. These meetings shall be conducted monthly, unless otherwise agreed, and shall be attended by the Engineer and/or a designated representative, the Contractor's superintendent, and representatives of all subcontractors, utilities and others that are active in the execution of the work. The purpose of these meetings shall be to determine the status of the work; to resolve conflicts; and, in general, to coordinate and facilitate expeditious prosecution of the work.

The Engineer and/or a designated representative will prepare the agenda of progress meetings which shall include review of the progress, payment requests, narrative reports, latest construction schedule update, and record documents. The Engineer and/or a designated representative will prepare and distribute meeting minutes.

- B. Progress and Schedule Review.** The progress of the work and the construction schedule shall be reviewed at the progress meetings to verify:
 - 1. Actual start and finish dates of completed activities since the last progress meeting.
 - 2. Duration and progress of all activities not completed.
 - 3. Reason, time and cost data for change order work that is to be incorporated into the construction schedule.
 - 4. Payment due to the Contractor.
 - 5. Reason and duration of required revisions.
- C. Review of Construction Schedule.** The Contractor shall submit a current construction schedule at the progress meeting in a form agreed upon by the Contractor and the Engineer. The construction schedule shall be in sufficient detail that the progress of the work can be evaluated accurately.
- D. Measurement and Payment.** No separate or additional payment will be made for preparation for or attendance at progress meetings, but shall be considered incidental to the work and shall be included in various unit or lump sum bid items.

Section 01230 - Preconstruction Conference

- A. After the Contract has been executed, but prior to the Contractor beginning the work, a preconstruction conference will be held between the Contractor, Engineer, Owner, and such other interested or affected parties as may be invited. The purposes of the preconstruction conference will be:
1. To review the initial construction schedule.
 2. To establish a working understanding among the various parties associated or affected by the work.
 3. To establish and review procedures for progress payment, notifications, approvals, submittals, etc.
 4. To establish normal working hours for the work.
 5. To review safety standards and traffic control.
 6. To discuss such other related items as may be pertinent to the work.
- B. The Contractor shall prepare and submit at the preconstruction conference the following:
1. A list of proposed subcontractors.
 2. A preliminary schedule of submittals.
 3. A list of material sources for review, if applicable.
 4. A construction schedule.
- C. **Measurement and Payment.** No separate or additional payment will be made for preparation for or attendance at the preconstruction conference, but shall be considered incidental to the work and shall be included in various unit or lump sum bid items.

Section 01340 - Shop Drawings, Product Data and Samples

A. General

1. Promptly after award of the Contract, the Contractor shall notify the Engineer in writing of the proposed sources of materials, suppliers and fabricators including addresses, telephone numbers and names of contact persons. Review by the Engineer is required for all sources of materials, suppliers and fabricators prior to any ordering, fabrication, processing, or delivery.
2. A Record of Materials, listing the materials for which source information will be required, and the submittal requirements for those items, will be given to the Contractor at the preconstruction conference. Submittal information for items shown in the Record of Materials, together with any other submittals that may be requested by the Engineer, shall be submitted sufficiently in advance of their need to allow for ordering, fabrication, inspection, delivery and installation, after the Engineer's review, in accordance with the reviewed construction schedule.
3. The Contractor shall coordinate, check, approve and submit shop drawings, samples, catalogs, catalog cuts, layouts, color charts, bills of material, test reports, and/or materials certifications as specified herein and in the relevant sections of these Contract Documents.

B. Shop Drawings

1. The Contractor shall assemble; label with reference to the relevant section of the specifications, and/or the drawing number, detail number, bid proposal item number, location, name and address, and delivery date; and provide all other pertinent data needed for a complete shop drawing. Deviations from the provisions in the Contract Documents shall be noted on the shop drawings.
2. Contractor shall submit shop drawings electronically in Adobe Acrobat file.
3. The Contractor shall verify all rough-in, backing or blocking, space requirements, field measurements, conformity to Contract Documents, code requirements where applicable, and necessary coordination with other parts of the work.
4. Form of Submittal: The Contractor shall submit a Request for Review of Materials, together with all drawings, to the Engineer for review. The request shall be submitted on a standard form supplied by the Engineer.

C. Product Data

1. The Contractor shall submit manufacturer's catalog cuts, illustrations, brochures, diagrams, mixing or installing instructions for all products specified in the Record of Materials, together with any other submittals that shall be requested by the Engineer. Submittals will be required for all materials requiring coordination, verification of requirements, selection of minor accessories, and as specified in each section of these Special Provisions. Additional or duplicating information also may be required, after review, for use by the Owner in the maintenance and operation of the facilities.
2. Form of Submittal: The Contractor shall submit a Request for Review of Materials, together with all product data, to the Engineer for review. The request shall be submitted on a standard form supplied by the Engineer.
3. Contractor shall submit product data electronically as an Adobe Acrobat, Excel or Word document file.

D. Samples and Color Selections

1. The Contractor shall submit samples, color charts and finish selection requirements as may be specified elsewhere in these Contract Documents.
2. *Samples.* Unless specified otherwise, the Contractor shall submit samples in a manageable size for mailing, and storage in the project file cabinet, and as follows:
 - a. Quantity: Contractor shall submit five (5) sets of samples.
 - b. Character: The material samples shall be representative of the production line, or the product produced by the manufacturer.
3. *Color Charts.* Unless otherwise specified, colors for selection are from the manufacturer's standard color selection as currently published or manufactured in effect at the time of the Invitation to Bid.

- E. After Engineer's Review.** The Engineer may require up to fourteen (14) calendar days from the date the submittals are received at the Engineer's office until they are returned to the Contractor. This time will increase if the drawings and information or samples submitted do not meet the contract requirements, or contain insufficient details.

If more than fourteen (14) calendar days are required for the Engineer's review of any individual submittal or resubmittal, an extension of time will be considered in accordance with the General Provisions.

After receiving the reviewed submittal, the Contractor shall:

1. Review and execute the direction of, and/or respond to, the Engineer's review comments.
2. Revise the material or information, if required, and date and identify revisions if any.
3. Submit revised project data for rejected submittals in the same form as specified above for original submittals.

F. Measurement and Payment. No separate or additional payment will be made for shop drawings, product data and samples, but shall be considered incidental to the work and shall be included in the various unit or lump sum bid items.

Section 01370 - Schedule of Values

Within ten (10) calendar days of receipt of the Notice to Proceed, the Contractor shall submit a complete breakdown of all lump sum bid items showing the value assigned to each part of the work for that item. Upon review by the Engineer of the breakdown of the lump sum price, the schedule of values shall be used as the basis for all progress payments. The schedule of values shall be coordinated and consistent with the reviewed construction schedule.

No separate or additional payment will be made for schedule of values, but shall be considered incidental to the work and shall be included in the various unit or lump sum bid items.

Section 01400 - Quality Control

The Contractor shall collect and test representative samples before incorporating material into the work. The type and quantity of tests shall be as listed in the specifications for each bid item. Test results shall be provided by the Contractor to the Engineer in accordance with Section 01340 of these specifications.

No separate or additional payment will be made for quality control as specified in this section. All costs of quality control shall be considered incidental to the work and shall be included in the various unit or lump sum bid item prices.

Section 01510 - Maintenance of Existing Facilities and Contractor Coordination

A. General. The Contractor may remove, relocate or adjust such existing facilities that are to remain, as may be necessary for the performance of the work, and rebuild any such disturbed existing facilities in as good condition as found (with minimum requirements as herein specified). The Contractor shall make all necessary or required revisions and perform all construction required by operations under the Contract, incident to any interference with power transmission and distribution, telephone, cable and other utility lines or with the maintenance of traffic or service thereon, all in a manner satisfactory to the owners and operators thereof.

The Contractor is warned that several groundwater and landfill gas monitoring wells exist at the Knott Landfill site. These wells consist of below ground and aboveground piping and covers, and are clearly marked in the field. All wells are not to be damaged or disturbed in any way by the construction activities or other operations of the Contractor. Should any of these wells be damaged by the Contractor's operations, the Contractor will be required to replace the groundwater monitoring wells, at Contractor's expense.

B. Cooperation with Other Contractors. The Owner and others will be working within the project area while the work is in progress. The Contractor shall schedule his work in conjunction with these other organizations to minimize mutual interference, in accordance with Section 01014.

C. Coordination of Work. The Contractor shall maintain overall coordination for the execution of the work. Based on the progress schedule prepared in accordance with these Special Provisions, the Contractor shall obtain from

each subcontractor a schedule and shall be responsible for all parties maintaining these schedules or for coordinating required modifications.

- D. Measurement and Payment.** No separate or additional payment will be made for maintenance of existing facilities during construction and contractor coordination, but shall be considered incidental to the work and shall be included in the various unit or lump sum bid items.

Section 01530 - Temporary Facilities, Utilities

- A. Electrical Service.** The Contractor shall arrange with the local utility to provide adequate temporary electrical service, if required for Contractor's operations, at a mutually agreeable location. The Contractor shall then provide adequate job site distribution facilities conforming to applicable codes and safety regulations. The Contractor shall provide, at Contractor's expense, all electric power required for construction, testing, general and security lighting, and all other purposes whether supplied through temporary or permanent facilities.

- B. Water.** Water is available from Avion Water Company using on-site fire hydrants. If Contractor elects to use this water source, Contractor shall procure a hydrant meter from Avion Water Company and pay any and all fees related to hydrant meter rental and water usage.

The Contractor shall pay for and shall construct any other facilities necessary to furnish water for Contractor's use during construction. Water used for human consumption shall be kept free from contamination and shall conform to the requirements of the State and local authorities for potable water.

- C. Temporary Lighting.** The Contractor shall provide temporary lighting in all work areas sufficient to maintain a lighting level during working hours not less than the lighting level required by OSHA standards.
- D. Sanitary Facilities.** The Contractor shall provide suitable chemical toilets or water closets at appropriate locations within the site of the work. The facilities shall be serviced weekly or more often if necessary. At the end of the job such toilets shall be removed completely.
- E. Payment.** No separate or additional payment will be made for temporary facilities and utilities, but shall be considered incidental to the work and shall be included in the various unit or lump sum bid items.

Section 01540 - Special Controls

- A. Public Safety and Convenience.** The Contractor shall at all times conduct work as to insure the least possible obstruction to traffic and inconvenience to the general public and the residents in the vicinity of the work, and to insure the protection of persons and property. No road or street shall be closed to the public except with the permission of the Engineer and proper governmental authority.

The Contractor shall control dust by applying water by means of tank trucks equipped with spray bars. Spray controls shall ensure that the water flows evenly and in the amounts required by the Engineer. The Engineer may direct that the Contractor apply water at night or early in the morning to reduce evaporation losses.

The Contractor shall conduct work, and take preventive measures, including performing dust control to minimize or reduce dust conditions, and such that dust in the project area shall not become objectionable to the adjacent property owners. Should the Owner determine the Contractor is not fulfilling obligations in this regard, the Owner reserves the right to take such action as may be necessary, and to charge the Contractor for any costs that may be incurred in such remedial action. No separate or extra measurement and payment of any kind will be made for dust control, including watering as may be necessary or required by the Engineer.

All work shall be carried on with due regard for the safety of the public. Open trenches shall be provided with barricades of a type that can be seen at a reasonable distance, and at night they shall be distinctly indicated by

adequately placed lights. Safety instructions received from the Engineer, Owner or applicable federal, state, or local agency shall be observed, but the following of such instructions shall in no way relieve the Contractor of responsibility or liability should any accident or loss occur as the result of Contractor's construction operations.

It shall be the Contractor's responsibility to see that all requirements of the Federal Williams-Steiger Occupational Safety and Health Act are observed and enforced to protect all the workers on the project, as well as the general public.

- B. Noise.** The Contractor shall comply with applicable federal, state and local rules and regulations. Daytime sound pressure levels shall comply with applicable federal, state and local regulations. All equipment working on the subject site shall be equipped with sound suppressers.

All costs incurred by the Contractor to comply with the noise restrictions shall be considered incidental to the construction bid items and no separate or additional payment will be made.

- C. Measurement and Payment.** No separate or additional payment will be made for special controls, but shall be considered incidental to the work and shall be included in the various unit or lump sum bid items.

Section 01570 - Traffic Maintenance and Protection

The Contractor shall provide traffic maintenance and protection in accordance with the Oregon Standard Specifications. The work shall be performed under a traffic control plan which has been reviewed by the Engineer and shall create a minimum of interruptions or inconveniences to pedestrian and vehicular traffic. Prior to commencement of construction operations, and not later than 10 days after receipt of Notice to Proceed, the Contractor shall provide in writing a plan of procedure of construction, traffic handling methodology, plans for routing traffic, safety provisions, sequence of operations and any other pertinent data relating to traffic regulation and protection for the public, as may be required. All such plans and provisions shall be submitted in accordance with Section 01340 of these Special Provisions.

All expenses involved in the maintenance of traffic, detours, bridges, barricades, signing, etc. shall be borne by the Contractor and amount thereof shall be included in the unit price or lump sum proposal.

Section 01700 - Project Closeout

- A. General.** It is the intent of these Contract Documents that the Contractor shall deliver a complete and usable facility capable of performing its intended functions and ready for use.
- B. Cleanup.** Throughout the period of construction the Contractor shall keep the work site free and clean of all rubbish and debris, and shall promptly remove from any portion of the site, or from property adjacent to the site of the work, all unused materials, surplus earth and debris, excepting select material which may be required for embankment, backfill, or grading.

Upon completion of the work, and prior to final acceptance, the Contractor shall remove from the vicinity of the work all plant, surplus material and equipment belonging to or used under Contractor's direction during construction.

- C. Waste Disposal.** The Contractor shall dispose of surplus materials, waste products and debris within the landfill at locations to be directed by the Engineer.

Ditches, washes, or drainage ways shall not be filled if this action may create water control problems. Disposal operations shall not create unsightly or unsanitary nuisances. The Contractor shall maintain the disposal site in a condition of good appearance and safety during the construction period.

Prior to final acceptance of the work, the Contractor shall grade the disposal site and cover all wasted material with soil cover.

- D. Project Record Document.** The Contractor shall maintain at the site, available to the Owner and Engineer, one copy of the Contract Documents, Drawings, shop drawings, change orders and other modifications in good order and marked to record all changes made during construction. These documents shall be delivered to the Engineer upon completion and prior to acceptance of the work.

Marking of the Drawings shall be kept current and be done at the time the material and equipment are installed. The Drawings shall be presented monthly to the Engineer for review.

- E. Touch-Up and Repair.** The Contractor shall touch-up or repair finished surfaces on structures, equipment, fixtures or installations that have been damaged prior to final acceptance. Surfaces on which such touch-up or repair cannot be successfully accomplished shall be completely refinished or, in the case of hardware and similar small items, the item shall be replaced.
- F. Releases.** The Contractor shall furnish, before final acceptance, a written release from the property owners of each property disturbed or otherwise interfered with by reason of construction pursued under this Contract, including disposal sites, whenever any of the work is accomplished on or through property other than that owned by the Owner. Should the release be, in the opinion of the Owner, arbitrarily withheld, then the Owner may, at its sole discretion, accept that portion of the work involved and cause final payment therefore to be made. The release must be signed by the Owner, or proper authority acting for the owner, of the property affected, stating that the restoration of the property has been satisfactorily accomplished.
- G. Measurement and Payment.** No separate or additional payment will be made for work performed under this section, but shall be considered incidental to the work and shall be included in the various unit or lump sum bid items.

Section 01710 - Contract Closeout Procedure

A. Substantial Completion

1. The Contractor shall submit the following:
 - a. A written certification to the Owner that the Project or designated portion of the Project is substantially complete; and
 - b. A list of items to be completed or corrected.
2. The Owner will make an inspection after receipt of Contractor's certification.
3. If it appears to the Owner that work is substantially complete:
 - a. The Owner may request of and the Contractor shall prepare and submit to the Owner, a list of items to be completed or corrected as determined by the inspection.
 - b. If the Owner then considers the work to be substantially complete, the Owner will issue a Certificate of Substantial Completion, with appropriate conditions, accompanied by a list of the items to be completed and corrected, as verified and amended by the Owner. Omission of any item from the list shall not relieve the Contractor from responsibility to complete all the work in accordance with the Contract.
 - c. The Owner may commence with occupancy of the Project or designated portion of the project.
 - d. The Contractor shall complete all the work within the time designated in the Certificate, or if not so designated within a reasonable time.

4. Should the Owner consider that work is not substantially complete:
 - a. Owner shall notify the Contractor, in writing stating reasons.
 - b. Contractor shall complete work and send second written notice to the Owner certifying that Project or designated portion of Project is substantially complete.

B. Final Inspection

1. The Contractor shall submit written certification that:
 - a. Work has been completed in accordance with Contract Documents.
 - b. Equipment and systems have been tested in presence of the Owner's representative and are operational.
 - c. The Project is completed, and ready for final inspection.
2. The Owner will make a final inspection within a reasonable time after receipt of certification.
3. Should the Owner consider that work is complete in accordance with requirements of Contract Documents, the Owner shall request the Contractor to make project closeout submittals.
4. Should the Owner consider that work is not complete:
 - a. Owner shall notify the Contractor in writing stating reasons.
 - b. The Contractor shall take immediate steps to remedy the stated deficiencies and upon completion send a second written notice to the Owner certifying that work is complete.
 - c. The Owner will reinspect work.

C. Reinspection Costs. If the Owner is required to perform second inspections because of inaccuracies in original certifications of the Contractor, the Owner will charge the Contractor for the resulting costs incurred by the Owner including consultant(s) fees.

D. Closeout Submittals

1. Project Record Documents: See the requirements of Section 01700-D.
2. Guarantees, Bonds and Letters of Credit required by these specifications.
3. Easement Release(s) if applicable.
4. At the close of the Contract the Contractor shall:
 - a. Pay all utility bills.
 - b. Remove all electrical, telephone, water, offices and any other temporary service equipment that may remain.

E. Release of Liens or Claims. Final acceptance will not be given until satisfactory evidence of release of liens has been submitted to the Owner.

F. Final Acceptance. The Engineer will provide the Owner with a Recommendation of Final Acceptance following satisfactory completion of the final punch list items and all the items listed above. Owner will then provide the Contractor with Final Acceptance which will begin the warranty periods. Date of Final Acceptance from the Owner sets the completion date of the Contract.

G. Final Adjustment of Accounts

1. Submit final statement of accounting to the Owner.
2. Statement shall reflect all uncompleted adjustments:
 - a. Additions and deductions resulting from:
 - 1) Previous Change Orders
 - 2) Cash allowances
 - 3) Unit prices
 - 4) Other adjustments
 - 5) Deductions for uncorrected work
 - 6) Penalties and bonuses
 - 7) Deductions for liquidated damages
 - b. Unadjusted sum remaining due.

H. Final Application for Payment. The Contractor shall submit a final application for payment.

I. Final Certificate for Payment

1. The Owner will issue Final Certificate for Payment.
2. Should final completion be materially delayed through no fault of the Contractor, the Owner may issue a Final Certificate for Payment, in accordance with the specifications and existing laws.

J. Post-Construction Inspection

1. Prior to expiration of one year from Date of Final Acceptance, the Owner may make visual inspection of the Project in company with the Contractor to determine whether correction of work is required, in accordance with provisions of the General Conditions.
2. For guarantees beyond one year, the Owner will make inspections after notification to the Contractor.
3. The Owner will promptly notify the Contractor, in writing, of any observed deficiencies.

K. Measurement and Payment. No separate or additional payment will be made for Contract closeout procedure, but shall be considered incidental to the work and shall be included in the various unit or lump sum bid items.

Section 01802 - Rate of Wages for Laborers and Mechanics

The Contractor is referred to the rates of minimum wages which shall be paid to the various classes of laborers and mechanics engaged in the performance of the Contract on the job site, contained elsewhere herein.

The minimum wages for the Knott Landfill – Cell 9 Construction Project shall not be less than the wages published by the State of Oregon Bureau of Labor and Industries under the title of *Prevailing Wage Rates for Public Works Contracts in Oregon (subject only to state law)*. The publication is available on BOLI’s web site at [BOLI Prevailing Wage Rate Book July 5, 2023.pdf \(oregon.gov\)](#)

No laborer or mechanic shall be permitted or required to work on Saturday, Sunday, or a legal holiday of the State or in excess of eight (8) hours on any other day unless they receive compensation for all hours worked on Saturday, Sunday, and

a legal holiday of the State or in excess of eight (8) hours on any other day at a rate not less than one and one-half times the basic hourly rate of pay. For the purposes of determining overtime compensation, the basic hourly rate of any laborer or mechanic shall not be less than the basic hourly rate determined by the Commissioner of the Bureau of Labor and Industries of the State to be the prevailing basic hourly rate for corresponding classes of laborers and mechanics on projects of similar character in the State.

The Contractor and Contractor's subcontractors shall pay all mechanics and laborers employed on the job site, unconditionally and not less often than once a week, and without deduction or rebate on any account, except as allowed by law, the full amounts of their wages including overtime, accrued to not more than five (5) working days prior to the time of payment, at wage rates not less than those referred to hereinabove, regardless of any contractual relationship which may be alleged to exist between the Contractor or subcontractor and the laborers and mechanics.

The rates of wages to be paid shall be posted by the Contractor in a prominent and easily accessible place at the job site. A copy of the rates of wages required to be posted, shall be given to each laborer and mechanic employed under the Contract by the Contractor at the time of employment, provided that where there is a collective bargaining agreement, the Contractor does not have to provide employees the wage rate schedule.

The Owner may withhold from the Contractor so much of the accrued payments as may be considered necessary to pay to laborers and mechanics employed by the Contractor or any subcontractor on the job site the difference between the wages required as hereinabove referred to and the wages received and not refunded to the laborers and mechanics.

No separate or additional payment will be made for the provisions of this Section, but shall be considered incidental to the work and shall be included in the various unit or lump sum bid items.

Section 01803 - Payrolls and Payroll Records

A certified copy of all payrolls shall be submitted to the Owner within the first 15 days of work and monthly thereafter. The Owner will make no progress payments under this Contract until the payroll records for the period have been submitted for review.

The Contractor shall be responsible for the submission of certified copies of the payrolls of all subcontractors. The certification shall affirm that the payrolls are correct and complete, that the wage rates contained therein are not less than the applicable rates contained in the wage determination decision of the Commissioner of the Bureau of Labor and Industries referred to hereinabove, and that the classifications set forth for each laborer or mechanic conform with the work performed.

Payroll records for all laborers and mechanics working at the site of the work shall be maintained by the general Contractor and Contractor's subcontractors during the course of the work and preserved for a period of three (3) years thereafter. The records shall contain the name of each employee, their correct classification, rate of pay, daily and weekly number of hours worked, deductions made and actual wages paid. The records shall be made available for inspection by the Owner, Commissioner of the Bureau of Labor and Industries of the State, and any authorized representatives thereof who may also interview employees during working hours on the job.

No separate or additional payment will be made for payrolls and payroll records, but shall be considered incidental to the work and shall be included in the various unit or lump sum bid items.

Section 01804 - Termination of Work on Failure to Pay Agreed Wages and Completion of Work

In the event that the Owner finds that any laborer or mechanic employed on the job site by the Contractor or any subcontractor has been or is being paid wages at a rate less than the required rate, the Owner may by written notice to the Contractor, terminate Contractor's right, or the right of any subcontractor, to proceed with the work or with the part of the work in which the required wages of compensation have not been paid and may complete such work or part by contract or

otherwise, and the Contractor and Contractor's sureties shall be liable to the Owner for any excess costs occasioned thereby.

No separate or additional payment will be made for the provisions of this Section, but shall be considered incidental to the work and shall be included in the various unit or lump sum bid items.

Division 2: Site Work

Section 02010 - Site Conditions

Subsurface explorations of soil and foundation conditions at the Knott Landfill have been performed and have been included as Part VII of these Contract Documents. Sound engineering judgment was exercised in preparing the subsurface information herein. The information was prepared and is intended for the Owner's engineering design and estimate. Its presentation with the Contract Documents is for the purpose of providing intended users with access to the same information available to the Owner.

The subsurface exploration of these conditions is presented in good faith and is not intended as a substitute for personal investigation, independent interpretation, or the judgment of the Bidder. The Bidder shall make his own deductions and conclusions as to the nature of the materials to be excavated, and difficulties that may arise from subsurface conditions and of doing any other work affected by the subsurface conditions, and shall accept full responsibility therefore.

No extra or additional payment will be made over and above the contract price due to any difference between the information relating to soil, rock and foundation conditions provided by the Owner and the conditions disclosed at the site of the work during the progress of the contract.

Section 02020 - Quality Control Testing

A. General. Quality control testing of soil and rock materials shall be performed by a geotechnical testing laboratory that is retained and paid for by the Contractor. Samples or locations to be tested shall be selected by the Engineer or his representative. The type of testing and frequency of its performance shall be as listed below.

B. Control Tests

1. *Particle Size.* Soil gradations as used in these specifications shall be defined in the laboratory utilizing test method ASTM D422.
2. *Compaction.* Maximum density of earthen material, as used in these Special Provisions, shall be defined as the maximum density obtained in the laboratory pursuant to test method ASTM D1557. In-place density of compacted backfill shall be determined by ASTM D2937, drive cylinder method, or by nuclear density test procedures per ASTM D2922. Moisture content shall be determined according to ASTM D2216, or ASTM D3017.
3. *Permeability.* The coefficient of permeability as used in these specifications shall be defined in the laboratory utilizing test method ASTM D2434.

C. Frequency of Testing

Quality control testing of soil and rock materials shall be performed by a geotechnical testing laboratory that is retained and paid for by the Contractor. Testing of the material shall be performed after installation of the materials has been completed, unless otherwise directed by the Engineer. The Contractor shall notify the Engineer when material installation is complete and shall anticipate that up to 24 hours will be required for the completion of each test.

1. *Particle Size.* The geotechnical testing laboratory will perform particle size testing at the following minimum frequencies:
 - a. Cushioning Layer - 1 every 2,500 cubic yards
 - b. Drainage Layer - 1 every 2,500 cubic yards

2. *Compaction.* Compaction testing will be performed by the Engineer or his representative. It shall be the responsibility of the Contractor to accomplish the specified compaction for backfill, fill, etc. Testing, rework and retesting shall not constitute a delay in contract time. The frequency of confirmation tests shall be as follows:
 - a. Embankment--1 every 500 cubic yards.
 - b. Cushioning Layer - 1 every 2,500 cubic yards.

If compaction fails to meet the specified requirements, the Contractor shall remove and replace the material at proper density, or shall modify the density to the specified level by other means acceptable to the Engineer.

3. *Permeability:* The geotechnical testing laboratory will perform laboratory hydraulic conductivity testing at the following minimum frequencies:
 - a. Drainage Layer -1 every 2,500 cubic yards

D. Measurement and Payment. No separate measurement or payment shall be made for Quality Control and Testing but shall be considered incidental to the work and shall be included in the various unit or lump sum bid items.

Section 02100 - Mobilization

A. Description. This work shall consist of preconstruction costs of preparatory work and operations performed by the Contractor, including, but not limited to, those necessary for the movement of his personnel, equipment, supplies and incidentals to the project site; for the establishment of his offices, buildings and other facilities necessary for work on this project; for the preparation of the health and safety plan; for premiums on bonds and insurance for the project and for work and operations which he must perform or costs he must incur before beginning production work on the various items on the project site. This cost also includes demobilization upon completion of the project. Mobilization costs for all subcontracted work shall be considered to be included.

B. Measurement and Payment. Measurement and payment for Mobilization shall be in accordance with Section 01150 and the following:

1. *Measurement:* Shall be measured by lump sum (LS), and shall not exceed ten (10%) percent of the overall contract cost.
2. *Payment:* Shall be paid for at the applicable contract lump sum price, payment for which shall constitute full compensation for project mobilization, including move in of personnel and equipment; set up of all temporary offices, facilities and utilities; provision of parking facilities for personnel working on the project; preparation of site health and safety plan; preparation of the Contractor staging area; preconstruction expenses; costs of the preparatory work and operations; and demobilization performed by the Contractor in association with this Contract as described in the Contract Documents. Payment will be made as follows:
 - (1) When five percent (5%) of the total original contract amount is earned from other bid items, excluding amounts paid for materials on hand, fifty percent (50%) of the amount bid for mobilization will be paid.
 - (2) When ten percent (10%) of the total original contract amount is earned from other bid items, excluding amounts paid for materials on hand, the remaining amount bid for mobilization will be paid.

Section 02110 – Interface Friction Angle Testing

- A. General.** Interface friction angle testing shall be performed by a certified geosynthetic testing laboratory that is retained and paid for by the Contractor. The type of testing and frequency of its performance shall be as listed below.
- B. Test Method.** Interface friction angles as used in these Specifications shall be as defined in the laboratory utilizing test method ASTM D5321-B. The tests shall utilize a 12-inch shear box; normal loads of 10, 30 and 60 pounds per square inch; a shear rate of 0.04 in/min; and shall test samples in a saturated and unsaturated condition after a 24-hour period of consolidation as described below. The maximum displacements given in the test method shall be utilized.
- C. Minimum Peak Friction Angles**

It shall be the responsibility of the Contractor to perform interface friction angle testing on each of the material interfaces that are planned. The minimum peak friction angles allowed on the interfaces shall be as follows:

<u>Interface</u>	<u>Minimum Peak Friction Angle</u>
1) On-site Soils/ Geosynthetic Clay Liner	22°
2) Geosynthetic Clay Liner / Geomembrane	22°
3) Geomembrane/ Geonet Composite	22°
4) Geonet Composite/ Drainage Layer	22°
5) Drainage Layer/ Separating Geotextile	22°

Geosynthetic materials which yield peak interface friction angle of less than those listed above shall not be utilized unless otherwise directed by the Engineer.

Please note that interface friction angle test results are required by the Engineer to review Geosynthetic Clay Liner Material, Geomembrane, Geonet Composite and Separating Geotextile submittals in accordance with Section 01340 of these Special Provisions. Review of these materials will not be performed until after interface friction angle test results have been received.

- D. Measurement and Payment.** Measurement and payment for Interface Friction Angle Testing shall be in accordance with Section 01150 and the following:
- Measurement:* Shall be measured by lump sum (LS).
 - Payment:* Shall be paid for at the applicable contract lump sum price, payment for which shall constitute full compensation for Interface Friction Angle Testing including sampling, shipping, sample preparation, testing, retesting if test results are below those specified, report preparation and all other work and incidental materials necessary to obtain interface friction angle test results as specified herein.

Section 02150 - Clearing and Grubbing

- A. Description.** The work under this Section consists of removing vegetation and buried matter and disposing of this material in a stockpile that is to be located adjacent to the working face of the landfill. The areas of work to be cleared and grubbed shall be those within the Cell 9 construction area and the Soil Stockpile Area, unless otherwise directed by the Engineer.
- B. Construction**
1. *Clearing and Grubbing Plan.* Prior to the start of work a clearing and grubbing plan shall be submitted for review in accordance with Section 01340 of these Specifications.
 2. *Clearing and Grubbing Operations.* Clearing and grubbing shall be performed in accordance with Section 00320 of the Oregon Standard Specifications, except as otherwise provided herein.
- C. Measurement and Payment.** Measurement and payment for Clearing and Grubbing shall be in accordance with Section 01150 and the following:
1. *Measurement:* Shall be measured by lump sum (LS). There will be no measurement of area or other measurement for work performed under this Section.
 2. *Payment:* Shall be paid for at the applicable contract lump sum price, payment for which shall constitute full compensation for clearing, grubbing, removal of structures, hauling, disposal, cleanup as well as performing all other work and incidentals necessary to complete the work as specified herein

Section 02200 - Excavation and Embankment

- A. Description.** This section describes the excavation, removal and stockpiling of material; embankment construction; compaction; finish grading; and all other earthwork in accordance with these specifications, in conformity with details shown on the drawings, and as directed by the Engineer. Excavation and embankment shall be performed in accordance with Section 00330 of the Oregon Standard Specifications, except as otherwise provided herein.
- B. Embankment Material**
- Soils from the Cell 9 excavation area shall be utilized for construction of any embankment that is required. Embankment material shall be free of organic matter, debris, and other deleterious substances. Embankment material shall have a maximum particle size of six (6) inches.
- C. Construction**
1. *Plan for Cell 9 Excavation:* Prior to the start of work, a plan for the usage of materials excavated from Cell 9 shall be submitted in accordance with Section 01340 of these Specifications. The plan shall describe the methods that will be utilized to identify, segregate and process materials that will be used for Cushion Layer, Drainage Layer, Base Course, Embankment, and other materials as described in these specifications.
 2. *Surveying.* Surveying shall be performed in accordance with Section 01050 of these specifications prior to the start of excavation/embankment work and after earthwork has been completed.
 3. *Weather Limitations.* Construct only when the weather conditions will not detrimentally affect the quality of the finished work. Any portion of excavations or embankments that are damaged by the effects of rain, wind, freezing temperatures, or other weather conditions during any phase of the construction shall be aerated if excessively wet, moistened if excessively dry, and reshaped and recompacted by the Contractor to conform to the requirements of the specifications, without additional compensation.

4. *Excavation.* The Contractor shall inform and satisfy himself in regard to the character, quantity, and distribution of all material to be excavated. Should the Contractor excavate below the designated lines and grades without prior permission, he shall replace such excavation with suitable materials, in a satisfactory manner and condition as directed by the Engineer, at his own expense.

The Contractor shall perform all excavation of every description, regardless of the type, nature, or condition of material encountered within the limits of the project to the lines and grades indicated on the drawings. The Contractor will encounter basalt rock in varying degrees of weathering and hardness. The basalt rock may be rippable, however, if harder and/or massive zones of basalt rock are encountered, pneumatic vibratory equipment (hoe-ramming) or blasting will be required.

Excavated refuse, when it is encountered, shall be disposed of at the working face of the landfill.

In the unlikely event that hazardous waste is encountered within the limits of the landfill, requiring excavation, the Contractor shall immediately stop work in this area and notify the Engineer. The Engineer will coordinate its removal with the Owner. The Contractor will not be required to handle hazardous waste. Work shall continue in other areas of the landfill until the Owner can remove the hazardous waste.

Any excavated material that is larger than six (6) inches shall be hauled to the crusher and utilized to produce aggregate that is in accordance with Section 02303 of these Specifications.

All excavated materials that are suitable for embankment material shall be placed in the fill areas. All material in excess of that needed for embankment construction and which is less than six (6) inches shall be hauled and placed in the Soil Stockpile Area shown on the drawings. Material placed in the Soil Stockpile Area shall have a maximum particle size of six (6) inches.

Equipment shall be routed to preclude pumping and/or subgrade damage. Where, in the opinion of the Engineer, pumping and wearing have progressed to an extent where damage to subgrade has occurred as evidenced by distortion of surface, rutting, or appearance at the surface of underlying undesiccated soils, the Contractor shall perform subgrade repair at no additional cost to the Owner.

During the process of excavation, the Contractor shall maintain the grade in such condition that it will be drained at all times. The Contractor shall install temporary drains and drainage ditches to intercept or direct surface-water which may affect the promotion or condition of the work.

A condition of excessive moisture will require that operations be temporarily suspended until drying weather permits use of the material or the materials are made suitable.

5. *Soil Stockpile Dust Control.* Upon completion of the placement of all material in the Soil Stockpile Area, the Contractor shall immediately apply a soil stabilizer and dust control product on the soil stockpile. Soil stabilizer and dust control product shall be DustControl DG as manufactured by Terra Novo, Inc. or approved equal.
6. *Subgrade Compaction.* The subgrade in excavated areas shall be compacted to at least 90 percent of the specified maximum dry density as defined by the Modified Proctor (ASTM D 1557). Soft or loose soils that do not compact readily after six passes with a 15-ton or larger, steel-wheeled roller, shall be removed and hauled to stockpile.
7. *Repair of Subgrade.* Settlement or washing that may occur from the action of the elements or any other cause, prior to acceptance of the work, shall be repaired, and grades reestablished to the elevations and slopes shown on the drawings without additional compensation.
8. *Lift Placement.* All fill placement shall occur on level surfaces. Each lift shall be blended with subsequent lifts to prevent the construction of a laminated fill.

Contractor shall allow the Engineer, or a designated representative, to periodically review the fill placement and document material quality and compaction.

9. *Embankment Compaction.* The compaction process shall be performed in a manner that achieves volumetric stability of the embankment. This will require that fill materials be moisture conditioned, placed in reasonably thin lifts (1 to 2 feet) and compacted to achieve at least 90% of the maximum dry density as defined by the Modified Proctor (ASTM D 1557).
10. *Moisture Content.* Place at a moisture content that will achieve the specified degree of compaction without inducing pumping or other instability to the satisfaction of the Engineer.
11. *Haul Routes.* All loaded and unloaded hauling equipment shall be continuously and uniformly routed over the entire width of the embankment. If continued hauling over a completed or partially complete embankment causes the loss of stability as evidenced by pumping, or rutting, or other damage, the Contractor shall repair the damaged embankment at his own expense, and adjust his hauling equipment and procedures to avoid further damage.
12. *Surface Finish.* Blading and rolling shall continue until the surface is smooth, free from waves and irregularities, and in conformance with the elevations shown on the drawings. If, at any time, the material is excessively wet, it shall be aerated by means of blade graders, harrows, or other suitable equipment until the moisture content is satisfactory. The surface shall then be compacted and finished as specified above.
13. *Surface Tolerance.* Grade surface to a tolerance of plus or minus 0.1 foot.

E. Measurement and Payment. Measurement and payment for Excavation and Embankment shall be in accordance with Section 01150 and the following:

1. Excavation.
 - a. Measurement: Shall be measured by the cubic yard (CY) in its original position. Surveying shall be performed prior to the start of any work on clearing and grubbing or excavation and after excavation has been completed. Pay quantities shall be computed to the neat lines of the cross sections as shown on the drawings, or as ordered by the Engineer.
 - b. Payment: Shall be paid for at the applicable contract unit price, payment for which shall constitute full compensation for excavation to subgrade including excavation of whatever material encountered, segregating, hauling, stockpiling, compacting, grading, surveying and testing as well as performing all other work and incidentals necessary to prepare the subgrade as shown on the drawings and as described in the specifications.
2. Embankment.
 - a. Measurement: Shall be measured by the cubic yard (CY) of compacted embankment material that has been constructed. Surveying shall be performed prior to the start of any work on clearing and grubbing or embankment construction and after embankment construction has been completed. Pay quantities shall be computed to the neat lines of the cross sections as shown on the drawings or as ordered by the Engineer.
 - b. Payment: Shall be paid for at the applicable contract unit price, payment for which shall constitute full compensation for the material in-place including hauling, stockpiling, spreading, aeration, moistening, placing, compacting, grading, surveying and testing as well as performing all other work and incidentals necessary to prepare the subgrade as shown on the drawings and as described in the specifications.

Section 02250 – Drilling and Blasting

- A. General.** This work consists of the drilling, blasting, processing, loading, hauling and placement of in-place basalt and all other associated earthwork in accordance with these specifications, in conformity with details shown on the drawings or as directed by the Engineer.

The County has a Conditional Use Permit for crushing operations and it has been included as Part VIII within these Contract Documents. The Contractor shall be responsible for complying with all requirements and stipulations specified in the Conditional Use Permit and for procuring any additional permits for rock crushing required by any local or state permitting authorities.

Contractor shall provide ten (10) day minimum notice to the Owner for all scheduled blasting activities to facilitate Owner notifications to surrounding property owners, as required by the Conditional Use Permit.

B. Construction

1. Blasting and Shot Rock Production. Shot rock shall be produced by a well executed blast and/or processing by other means (such as crushing or secondary breakage) to transform the basalt formation into fragments small enough to be accepted by the Contractors aggregate processing equipment. Blasting operations shall be performed in accordance with Section 00335 of the ODOT Standard Specifications except as otherwise provided herein and with the following modifications:
 - Delete subsection 00335.80
 - Delete subsection 00335.90
2. For each blasting operation, the Contractor shall monitor amplitude of vibration and horizontal particle velocity at two (2) locations near or beyond the perimeter of Knott Landfill. Specific locations will be determined by the Engineer.

C. Measurement and Payment

No separate or additional payment will be made for Drilling and Blasting, but shall be considered incidental to the work and shall be included in the applicable unit or lump sum bid items.

Section 02300 - Cushioning Layer

- A. Description.** The work under this section consists of furnishing and installing the cushioning layer in accordance with these specifications, and in conformance with the lines, grades, depth, and cross-sections shown in the drawings, or as established by the Engineer.
- B. Materials.** Cushioning layer material shall be on-site material that is excavated by the Contractor from the Cell 9 area. Materials excavated by the Contractor for use as cushioning layer material shall consist of pit-run and/or manufactured soils composed of sand with fine gravel and silt sand with fine gravel and silt within the limitations of the following table:

Cushioning Layer Gradations	
U.S. Standard Sieve	Percent Passing
3/4 inch	100

Particle size testing shall be in conformance with Section 02020 of these specifications.

C. Construction. The cushioning layer shall be placed to the lines, grades, and thicknesses shown on the drawings, and shall consist of the material specified above. The cushioning layer shall provide a smooth, stabilized surface on which to place overlying materials.

1. *Preparation of Subgrade.* Subgrade preparation shall consist of dressing, shaping, wetting, and compacting the area exposed by excavation to a minimum density of 90 percent, in accordance with the specifications. Surface shall be cleaned of all foreign substances and debris. Any ruts or soft yielding spots that may appear in the subgrade shall be corrected by loosening, removing, and adding cushioning layer; reshaping; and recompacting the affected areas to the line, grade, and specified density requirements.
2. *Surveying.* The Contractor shall provide and maintain a means of continuously observing the thickness of the cushioning layer, such as an equipment mounted global positioning system (GPS). Stakes will not be allowed.
3. *Placing.* Cushioning layer material shall be deposited, and spread in a uniform layer to the required contour and grades, and to such a loose lift that, when compacted to the density required, will achieve the specified thickness. The material shall be spread uniformly on the prepared subgrade from moving vehicles or spreading boxes, then leveled to the required contour and graded with blade graders. Portions of the layer that become segregated in spreading shall be remixed to the required gradation.
4. *Compacting.* The cushioning layer shall be compacted to at least 90 percent of maximum dry density.
5. *Surface Finish.* Blading and rolling shall continue until the surface is smooth and free from waves and inequalities. If at any time the mixture is excessively moistened by rain, it shall be aerated by means of blade graders, harrows, or other equipment until the moisture content is such that the surface can be recompacted and finished as above. The finished layer shall be maintained by the Contractor in the above-described condition until the GCL is applied. Contractor shall use a smooth drum roller to apply the surface finish to the cushioning layer. Sideslope areas may require the roller application to be performed with the use of a cable from the top of the slope. The surface of the cushioning layer, when finished, shall not show any deviation in excess of 0.1 feet when tested with a 10-foot straight-edge. Any deviation in excess of this amount shall be corrected by loosening, adding, or removing material and reshaping and compacting to satisfy the above requirement.

D. Measurement and Payment. Measurement and payment for Cushioning Layer shall be in accordance with Section 01150 and the following:

1. *Measurement:* Shall be measured by the cubic yard (CY) of compacted material, in place, that is constructed in accordance with these specifications, and limited to the neat lines of the cross-sections as shown on the drawings, or as directed by the Engineer.
2. *Payment:* Shall be paid for at the applicable contract unit price, payment for which shall constitute full compensation for cushioning layer including screening, hauling, stockpiling, spreading, aeration, moistening, grading, compacting, testing and all other work and incidentals necessary to place the material as shown on the drawings and described in the specifications. Excavation shall be paid for under Section 02200 of these Special Provisions.

Section 02301 – Drainage Layer

A. Description. This work shall consist of loading, hauling and installing drainage layer material in accordance with these specifications and in conformance with the lines, grades, depth, and typical cross-sections shown in the drawings, or as established by the Engineer.

B. Materials

1. *Drainage Layer*

Drainage Layer material has been stockpiled on the northwest corner of the landfill at the location shown on the Drawings. The material utilized by the Contractor as Drainage Layer material shall consist of gravel within the gradation limits of the following table:

Drainage Layer Gradations	
U.S. Standard Sieve	Percent Passing
1-1/2 inch	100
1-1/4 inch	95 to 100
1 inch	60 to 100
3/4 inch	25 to 100
1/2 inch	0 to 75
1/4 inch	0 to 20
No. 10	0 to 10
No. 40	Less than 3%

The Drainage Layer material shall have a permeability of greater than or equal to 1 cm/sec as determined by ASTM D-2434. Particle size and permeability testing shall be in conformance with Section 02020 of these specifications.

C. Construction

1. *Plan for Material Placement.* Prior to placement of drainage layer material and leachate collection gravel, the Contractor shall submit to the Engineer for review, methods for material placement and procedures that will be followed if a wave in the geomembrane is formed.
2. *Surveying.* The Contractor shall provide and maintain a means of continuously observing the depth of the drainage layer material, such as an equipment mounted global positioning system (GPS). Stakes will not be allowed.
3. *Presence of Construction Monitor.* A monitor that is provided by the Engineer shall be present at all times during the placement and grading of the drainage layer material/leachate collection gravel overlying the geomembrane, unless this requirement is waived by the Engineer. The Contractor shall provide timely notice (at least one working day in advance of placement or grading) to allow time for the Engineer to arrange for the inspector.
4. *Geomembrane Manufacturer's Certification.* Prior to placement of any material on the geomembrane, the geomembrane manufacturer's representative shall furnish the Engineer with certification that the geomembrane was installed in accordance with the manufacturer's recommendations.
5. *Geomembrane Surface Temperatures.* Placement of drainage layer material/leachate collection gravel shall only be performed when geomembrane surface temperatures are less than the geomembrane surface temperatures were when the geomembrane was welded. The geomembrane is extremely sensitive to changes in temperature. Increases in temperature will cause the length and width of each individual sheet to expand significantly, and will cause a wave to be formed in the geomembrane during placement of the cover material.
6. *Placement of Material.* The initial lift thickness shall be at least 12 inches thick. Track-mounted equipment with low ground-pressure treads including backhoes, no larger than a Caterpillar Model D-6 or equivalent, shall be used for spreading. Maximum average track pressure shall not exceed 4.6 psi. In no case shall tracked

equipment be allowed to operate on less than 12 inches of cover over the geomembrane liner. The Contractor shall avoid sharp turns and sudden darts or stops that may damage the geomembrane.

Material covering the landfill slope shall be pushed up from the bottom. To avoid stressing the geomembrane, material shall not be pushed in from the top of the slope.

During hauling and placement of material, its contamination shall be prevented. If the drainage layer material becomes contaminated, the Contractor shall remove the contaminated material and replace it at the Contractor's sole expense.

7. *No Tensile Forces.* If tensile forces are transmitted to the geomembrane during placement of the drainage layer material, a wave in the geomembrane will be formed. Under no circumstances shall the wave in the geomembrane be allowed to remain.
8. *Folding or Creasing of Geomembrane.* At no time shall the geomembrane be folded or creased during placement operations. If a wave in the geomembrane is formed during material placement, which is likely to form a fold or crease in the opinion of the monitor, work in the adjacent areas shall immediately cease and the wave shall be removed.
9. *Damage Repair.* The location of any damage to the geomembrane by equipment shall be marked for repair. Any and all work associated with repair of the liner system shall be at the Contractor's sole expense.

D. Measurement and Payment. Measurement and payment for Drainage Layer material shall be in accordance with Section 01150 and the following:

1. *Measurement:* Shall be measured by the cubic yard (CY) of material, in place, that is constructed in accordance with these specifications, and limited to the neat lines of the cross-sections as shown on the drawings, or as directed by the Engineer.
2. *Payment:* Shall be paid for at the applicable contract unit price, payment for which shall constitute full compensation for the material, in-place, including loading, hauling, stockpiling, spreading, grading, testing and all other work and incidentals necessary to place the material as shown on the drawings and described in the specifications.

Section 02302 – Base Course

A. Description. This work shall consist of furnishing and installing Base Course in accordance with these specifications and in conformance with the lines, grades, depth, and typical cross-sections shown in the drawings, or as established by the Engineer.

B. Materials

1. Base Course

Base Course shall be furnished by the Contractor. The material supplied shall consist of crushed and processed basalt within the limits of the following table:

Base Course Gradations	
U.S. Standard Sieve	Percent Passing
3/4 inch	90 to 100
3/8 inch	55 to 75
1/4 inch	40 to 60
No. 40	8 to 26
No. 200	0 to 15

C. Construction

1. *Preparation of Subgrade.* Subgrade preparation shall consist of dressing, shaping, wetting, and compacting the area to receive Base Course to a minimum density of 95 percent Modified Proctor (ASTM D-1557). Surface shall be cleaned of all foreign substances and debris. Any ruts or soft yielding spots that may appear in the subgrade shall be corrected by loosening, removing, and adding cushioning layer; reshaping; and recompacting the affected areas to the line, grade, and specified density requirements.
2. *Placement of Material.* Base Course shall be installed in accordance with Section 00640 of the Oregon Standard Specifications at the locations shown on the Drawings.
3. *Base Course Compaction.* Base Course material shall be compacted to have a maximum dry density as defined by the Modified Proctor (ASTM D 1557) that is 95 percent or greater.

D. Measurement and Payment. Measurement and payment for Base Course material shall be in accordance with Section 01150 and the following:

1. *Measurement:* Shall be measured by the cubic yard (CY) of material, in place, that is constructed in accordance with these specifications, and limited to the neat lines of the cross-sections as shown on the drawings, or as directed by the Engineer.
2. *Payment:* Shall be paid for at the applicable contract unit price, payment for which shall constitute full compensation for the material, in-place, including crushing, screening, loading, hauling, stockpiling, subgrade preparation, spreading, grading, compacting, testing and all other work and incidentals necessary to place the material as shown on the drawings and described in the specifications.

Section 02303 – Aggregate in Stockpile

A. Description. This work shall consist of manufacturing and stockpiling of aggregate materials in accordance with these specifications, or as established by the Engineer. Rock that is excavated from the Cell 9 area shall be crushed, screened and stockpiled to be within the gradation limits listed below.

B. Materials

1. 2 inch Minus Aggregate

2 inch Minus Aggregate material shall be manufactured by the Contractor from the rock excavated from within the Cell 9 Limit of Work. The material manufactured by the Contractor for 2 inch Minus Aggregate- Select shall consist of gravel within the gradation limits of the following table:

2-inch Minus Aggregate	
U.S. Standard Sieve	Percent Passing
2 inch	100
3/4 inch	70
No. 200	Less than 20%

C. Construction

1. *Plan for Miscellaneous Aggregate Production.* Prior to mobilization and installation of the crushing and screening plant, the Contractor shall submit to the Engineer for review, a work plan describing proposed methods, equipment, and stockpiling plans for aggregate production.
2. *Plan for Material Stockpiling.* Prior to stockpiling of aggregate materials, the Contractor shall submit to the Engineer for review a plan for material stockpiling.

D. Measurement and Payment. Measurement and payment for 2 inch Minus Aggregate material shall be in accordance with Section 01150 and the following:

1. *Measurement:* Shall be measured by the cubic yard (CY) of material, stockpiled, that is constructed in accordance with these specifications, or as directed by the Engineer.
2. *Payment:* Shall be paid for at the applicable contract unit price, payment for which shall constitute full compensation for the material, in-place, including crushing, screening, loading, hauling, stockpiling, testing and all other work and incidentals necessary to place the material as shown on the drawings and described in the specifications.

Section 02306 – Hot Mixed Asphalt Concrete (HMAC)

A. Description. This work shall consist of furnishing and installing Hot Mixed Asphalt Concrete (HMAC) in accordance with these specifications, Section 00744 of the Oregon Standard Specifications, and in conformance with the lines, grades, depth, and typical cross-sections shown in the drawings, or as established by the Engineer.

B. Materials

HMAC shall be 1/2-inch or 3/8-inch minus, dense graded mix as described in Section 00744 of the ODOT Standard Specifications for Level 2 HMAC. The HMAC shall include Modified Binder PG 64-28 and have air voids that are 4 percent or lower.

C. Construction

1. *Job Mix Formula (JMF).* A Job Mix Formula (JMF) that is in accordance with Section 00744 of the ODOT Standard Specifications shall be submitted for review at least 10 days prior to the start of work.
2. *Placement of Material.* HMAC shall be installed in accordance with Section 00744 of the ODOT Standard Specifications except as modified herein.
3. *HMAC Compaction.* HMAC shall be compacted to have a maximum density as defined by Section 00744.49 of the ODOT Standard Specifications that is greater than 96 percent relative to maximum density as determined by JMF.

D. Measurement and Payment. Measurement and payment for Hot Mixed Asphalt Concrete (HMAC) material shall be in accordance with Section 01150 and the following:

1. *Measurement:* Shall be measured by the cubic yard (CY) of material, in place, that is constructed in accordance with these specifications, and limited to the neat lines of the cross-sections as shown on the drawings, or as directed by the Engineer.
2. *Payment:* Shall be paid for at the applicable contract unit price, payment for which shall constitute full compensation for the material, in-place, including furnishing, loading, hauling, spreading, grading, compacting, testing and all other work and incidentals necessary to furnish and install the material as shown on the drawings and described in the specifications.

Section 02311 - Geosynthetic Clay Liner

A. Description

1. *General.* The work described in this Section shall consist of providing all operations pertaining to the furnishing, installing and testing of the geosynthetic clay liner (GCL) in accordance with the specifications, in conformity with the lines and grades shown on the drawings, and as directed by the Engineer.
2. *Definitions*
 - a. *GCL Manufacturer:* The party responsible for the production of the GCL rolls from bentonite and geotextile.
 - b. *Installer:* The party responsible for field handling, storing, deploying, seaming, temporary restraining (against wind) and other site aspects of the GCL installations, including geomembranes and geotextiles. Also responsible for transportation of these materials to the site and for the anchoring systems.
 - c. *Panel.* The unit area of the GCL that will be placed in the field. A panel may be identified as a roll or a portion of a roll.
3. *Quality Assurance Qualifications.* The GCL shall be furnished by a manufacturer that has previously installed a minimum of 5,000,000 square feet of the material in the past two (2) years in similar landfill installations. The GCL Installer shall have installed a minimum of 1,000,000 SF of material in the past two (2) years in similar landfill installations.
4. *Warranty.* The Contractor shall obtain and furnish to the Owner a warranty from the Geosynthetic Clay Liner manufacturer for the GCL materials used in the Work. The GCL material warranty shall be for defects or failure for twenty years after final acceptance on a prorata basis.

B. Submittals. As noted, submittals shall be made before commencing the work specified in this Section. Copies of the following information and material shall be provided in accordance with Section 01340 of the specifications.

1. *Product Data and Factory Test Results.* Published product properties and specifications for the proposed GCL, as well as factory test results of materials certified by the GCL manufacturer shall be submitted showing conformance with the requirements of these specifications. In addition, the Contractor shall submit the manufacturer's certification stating that the material proposed is similar to and of the same formulation as that for which test results are submitted, and by which actual usage has been demonstrated to be satisfactory for the intended application.
2. *Quality Assurance/Quality Control.* The manufacturer's plan for quality assurance/quality control shall be submitted to the Engineer for review. The plan shall address each item in the material specification and address procedures for quality control.

3. *Delivery, Storage and Handling Instructions.* The manufacturer's recommendations for delivery, storage and handling shall be submitted to the Engineer for review.
4. *Interface Friction Angle Test Results.* Interface friction angle test results that are in accordance with Section 02110 of these Specifications.
5. *Installation drawings, Procedures and Schedules.* Installation drawings, procedures and a schedule for carrying out the work shall be provided by the Contractor to the Engineer for review. Items addressed by the Contractor shall include but not be limited to material unloading, storage, installation, repair, and protection to be provided in the event of rain; a schedule showing the order of placement, location of panels, seams and penetrations; and drawings showing the panel layout, seams and associated details. Following review, these drawings will be used for installation of the GCL. Any deviations from these drawings must be approved in writing by the Engineer.
6. *Post-Installation Requirements.* Upon completion of the installation, the Contractor shall submit the following:
 - a. Certificate stating that the GCL has been installed in accordance with the drawings, specifications, and the manufacturer's recommendations.
 - b. Manufacturer's and Installer's Warranties.

C. Materials

1. *General.* The GCL shall consist of bentonite encased, front and back, with 6.0 oz/sq yd non-woven geotextile. The materials supplied under these specifications shall be first quality products designed and manufactured specifically for the purposes of this work, and which have been satisfactorily demonstrated by prior use to be suitable and durable for such purposes. The GCL shall be Bentomat DN as supplied by Colloid Environment Technologies Company (CETCO), or BentoLiner NWL as supplied by GSE Lining Technology Inc., or equal.

All GCL specifications shall be met on a minimum average roll value (MARV) basis by the manufacturer.

2. *Bentonite Properties.* Requirements for the bentonite component of the GCL shall be as follows (unless otherwise noted):

Property	Test Method	Units	Value
Swell Index	ASTM D5890	ml/2g	24
Fluid Loss	ASTM D5891	ml	18 max.

3. *Hydraulic Properties.* The maximum hydraulic conductivity of the GCL shall be as follows:

Property	Test Method	Units	Value
Flux (5 psi confining stress and 2 psi head pressure)	ASTM D 5887	m ³ /m ² -s	1x10 ⁻⁸

4. *Physical Properties - Geotextile Encased GCL.* Requirements for the physical properties of the geotextile encased GCL shall be as follows:

Property	Test Method	Units	Value
Bentonite Content	ASTM D 5993	lb/sf	0.75
Tensile Strength	ASTM D 6768	lb/in	50
Peel Strength	ASTM D 6496	lb/in	3.5
Hydrated Internal Shear Strength (at 200 psf normal stress)	ASTM D 6243	psf	500

5. *Roll Characteristics.* The GCL shall be supplied in rolls with minimum dimensions as follows:
- Width = 14 feet
- Length = 150 feet
- Core Dia. = 4 inches I.D.
6. *Manufacturer Source Quality Control.* Perform the following quality control tests at the manufacturing plant for the GCL product:

<u>Property Test</u>	<u>Method</u>	<u>Frequency</u>
Bentonite Content	ASTM D 5993	One per 40,000 SF
Grab Tensile Strength	ASTM D 6768	One per 200,000 SF
Peel Strength	ASTM D 6496	One per 40,000 SF

7. Geotextiles utilized in the GCL shall be needle punched. Needle detecting devices shall be utilized prior to roll up and shipment to minimize the presence of broken needles in the final product.

D. Construction

1. *Delivery, Marking, and Packaging.* The GCL shall be shipped in rolls and each roll shall be packaged in a waterproof, UV resistant outside covering. Folded material will not be accepted. Any evidence of folding shall be cause for rejection of the material by the Engineer.

Each roll of GCL shall be given prominent, unique, indelible identifying markings, indicating the sheet number, date of fabrication, and proper direction of unrolling to facilitate layout and positioning in the field. A continuous match line shall be printed on the sheet to indicate minimum recommended overlap. The exterior packaging shall be prominently identified in the same fashion as the sheet within and show the date of shipment.

2. Storage and Handling.

The material shall be handled in strict accordance with the manufacturer's recommendations.

The GCL storage area shall be prepared and reviewed for acceptability prior to the arrival of any material. The Contractor shall submit a written narrative, describing methods of unloading, storage and installation of the material, to the Engineer for review. The submittal shall delineate the responsibility of the Contractor for the material, and its protection from the weather during each phase of the construction process. No material shall be accepted at the site, and no payment shall be made for any of the GCL until this submittal has been satisfactorily reviewed. Under no circumstances shall this review relieve the Contractor from providing adequate protection for the material during all phases of the construction.

The GCL storage area shall be protected and secured from the following:

- (1) Water: The GCL shall be stored in either the original watertight shipping containers, or in a warehouse with a concrete floor and a roof. The material shall not be stored in any areas where ponding could occur. The material shall be protected from water at all times.
- (2) Man or Animal: The storage area shall not be near or adjacent to areas frequented by the general public, unless a fence with a locking gate is provided.
- (3) Dirt/Dust: Dirt or dust will prevent proper bonding from occurring. Material shall be stored in the watertight, UV resistant packaging until the material is ready to be placed.
- (4) Extreme Heat: The material shall be protected from direct sunlight.

3. *Conformance Testing.*

Conformance testing shall be performed in accordance with the following requirements.

- a. Engineer shall identify where samples are to be taken.
- b. Sampling Procedures:
 - Sample across the entire width of the roll excluding the first 3 feet.
 - Cut sample 3 feet by the width of the roll
- c. The Installer shall forward samples to Geosynthetic Quality Assurance Laboratory.
- d. The GQA Laboratory shall perform the following tests.

Property Test	Method	Frequency
Bentonite Content	ASTM D 5993	One per 50,000 SF
Tensile Strength	ASTM D 6768	One per 50,000 SF
Peel Strength	ASTM D 6496	One per 50,000 SF
Index Flux	ASTM D 5887	One per 200,000 SF

All costs for quality control and testing of the GCL material and installation shall be borne by the Contractor.

4. *Subgrade Inspection.* Immediately prior to the placement of each panel, the area to be covered shall be walked by the Engineer to determine the acceptability of the subsurface. No debris, rocks, survey stakes, or any other objects that protrude will be allowed.
5. *Preparation.* The Contractor shall repair damage caused to subgrade during deployment and shall excavate anchor trenches prior to deployment.
6. *GCL Integrity.* The Contractor shall coordinate placement of the GCL with the placement of the geomembrane to maintain the integrity of the GCL at all times. Any material damaged prior to final acceptance of the project, whether due to weather, construction methods, etc., shall be removed and replaced by the Contractor at his sole expense. The GCL is water sensitive and shall be protected from contact with water.
7. *Installation of the GCL*
 - a. The GCL shall be placed in accordance with the reviewed panel layout drawings and the manufacturer's recommendations.
 - b. The GCL shall be installed so that the seams of the material laid on the sideslopes are perpendicular to the landfill bottom. All material shall be pulled tight to smooth out creases, wrinkles or irregularities. No horizontal seams shall be allowed on the sideslopes. The material shall be deployed from the highest to the lowest point and shall be deployed down the slope, not across the slope.
 - c. The GCL shall not be placed in standing water or while raining. Any material that becomes hydrated shall be removed and replaced by the Contractor.
 - d. The GCL seams shall be laid with a 6 inch minimum overlap on each side. Seams shall be heat listered. All seams shall be installed in accordance with manufacturer's recommendations.
 - e. The GCL shall be placed in such a manner to ensure a minimum of handling. The method and equipment used to deploy the GCL shall not damage the GCL or the supporting surface. No machinery or equipment shall be parked or trafficked over the GCL. Any portion of material damaged during the project shall be removed and replaced or repaired. Any necessary repairs to the GCL shall be patched with a piece of the same material. The patch size shall be 12 inches greater than the damaged area, in every direction.

- f. Place ballast (i.e., sandbags) on GCL that prevents uplift from wind and will not damage the GCL. The use of tires for anchoring shall not be allowed.
- g. Only as much GCL shall be deployed in a given day as can be covered during that day by geomembrane. The GCL Installer shall coordinate the placement of GCL with the placement of the geomembrane so as to minimize the exposure of the GCL to the elements. The Contractor shall be prepared to cover all exposed GCL, at any time, in the event of any form of precipitation.

E. Measurement and Payment. Measurement and payment for Geosynthetic Clay Liner shall be in accordance with Section 01150 and the following:

1. *Measurement:* Shall be measured by the square foot (SF) of surface area covered, in place, complete, limited to the dimensions shown on the drawings, and where ordered by the Engineer. Measurements shall be made on material actually in place as measured normal to the slope. Where multiple layers of GCL are shown on the drawings, each layer shall be measured. No allowance shall be made for the overlapping or splicing that is required for seaming.
2. *Payment:* Shall be paid for at the applicable contract unit price, payment for which shall constitute full compensation for anchor trench excavation, furnishing and installing geosynthetic clay liner, storage, seaming, repairs, weather protection and testing as well as performing all other work and incidentals necessary to provide the geosynthetic clay liner as shown on the drawings and described in the specifications.

Section 02312 - Geomembrane

A. Description

1. *General.* The work described in this Section consists of providing all operations pertaining to the furnishing, installing, and testing of the high density polyethylene (HDPE) geomembrane, in accordance with the specifications and in conformity with the lines and grades shown on the drawings, and as directed by the Engineer.
2. *Definitions.*
 - a. Construction Quality Assurance (CQA) Monitor: The site representative for the Engineer.
 - b. Geosynthetic Quality Assurance Laboratory (GQAL): The party, retained by the Contractor and independent of the Manufacturer, Installer, or Owner, that is responsible for conducting and documenting tests on geosynthetic samples obtained at the site.
 - c. Geomembrane Manufacturer: The party responsible for the production of the geomembrane rolls from resin and for the quality of the resin.
 - d. Installer: The party responsible for field handling, storing, deploying, seaming, on-site testing, temporary restraining (against wind), and other aspects of the geosynthetics installations, including geomembranes, geotextiles, and geonet composites.
 - e. Panel: The unit area of geomembrane that will be seamed in the field. A panel is identified as a roll or a portion of a roll.
3. *Quality Assurance Qualifications.*
 - a. Installation of the geomembrane shall be performed by an installer that has previously installed a minimum of 15,000,000 square feet of the material (HDPE) within the past five (5) years, in similar landfill installations.
 - b. All liner superintendents assigned to the project shall have satisfactorily installed 5,000,000 square feet of the material (HDPE) within the past three (3) years.
 - c. All welding machine operators shall have shown proven performance on previous geomembrane installations and shall have seamed a minimum of 500,000 square feet of HDPE in the last three (3) years. All welding machine operators shall perform a demonstration of their welding technique and a test of the welds which they have performed prior to any welding on the project.
4. *Warranty.* The Contractor shall furnish the Owner a warranty from the installer of the HDPE geomembrane which warrants their workmanship to be free of defects on a prorata basis for 2 years after the final acceptance of the work. This warranty shall include but not be limited to all field welded seams, anchor trenches, attachments to appurtenances, and penetration seals.

The Contractor shall furnish the Owner a warranty from the HDPE geomembrane manufacturer for the materials used. The material warranty shall be for defects or failures related to manufacture on a prorata basis for 20 years after the final acceptance of the work.

- B. Submittals.** Unless otherwise noted, submittals shall be made before commencing the work specified in this Section. The following information and material shall be provided in accordance with Section 01340 of the specifications.

1. *Product Data and Factory Test Results.* Published product properties, specifications and seaming techniques for the proposed HDPE, including, but not limited to resin, roll information, and extrudate, as well as factory test results of materials, certified by the HDPE geomembrane manufacturer shall be submitted showing conformance with the requirements of these specifications. In addition, the Contractor shall submit the manufacturer's certification stating that the material proposed is similar to and of the same formulation as that

for which test results are submitted, and by which actual usage has been demonstrated to be satisfactory for the intended application.

2. *Quality Assurance/Quality Control.* The manufacturer's plan for quality assurance/quality control shall be submitted to the Engineer for review. The plan shall address each item in the material specification and address procedures for quality control.
3. *Interface Friction Angle Test Results.* Interface friction angle test results that are in accordance with Section 02110 of these Specifications.
4. *Qualifications.* The Contractor shall:
 - a. Submit list of equipment and personnel proposed for the project. Include equipment type and quantities. Include personnel experience on similar projects.
 - b. Submit resume and references of installation supervisor to be assigned to the project, including dates and duration of employment and pertinent experience information.
 - c. Submit resumes and references of installation welders who will perform seaming operations, including dates and duration's of employment and pertinent experience information.
5. *Delivery, Storage and Handling Instructions.* The manufacturer's recommendations for delivery, storage and handling shall be submitted to the Engineer for review.
6. Installation drawings, Procedures and Schedules.
 - a. Installation drawings, procedures, and a schedule for carrying out the work shall be provided by the Contractor to the Engineer. Shop drawings shall have geomembrane sheet layout with proposed size, number, position, and sequence of placing of all factory fabricated sheets, and indicating the location of all field joints and the direction of shop joints on each sheet. Shop drawings shall also show complete details and/or methods for anchoring the geomembrane at the edges of the geomembrane, and making field seams. Following review, these drawings will be used for installation of the geomembrane.
 - b. Procedures addressed by the Contractor shall include, but not be limited to, material unloading, storage, installation, repair, and protection to be provided in the event of rain. A schedule showing the order of placement, location of panels, seams and penetrations shall be submitted for the Engineer's review.
7. *Field Quality Control Documents.* Contractor shall submit daily quality control documentation prepared during installation.
8. *Post-Installation Requirements.* Upon completion of the installation, the Contractor shall submit the following:
 - a. Certificate stating that the geomembrane has been installed in accordance with the drawings, specifications, and the manufacturer's recommendations.
 - b. Manufacturer's and Installer's warranties.
 - c. Record Drawing Information: Record drawings including but not limited to drawings showing the true panel dimensions, location and coordinates of all seams, panels with roll numbers, repairs, patches, destructive test locations, anchor trenches, and other appurtenances, including measurements and dimensions, shall be prepared by the Contractor and submitted to the Engineer following completion of the project.

C. Materials

1. *General.* The materials supplied under these specifications shall consist of new, first quality products, designed and manufactured specifically for the purpose of this work, which shall have been satisfactorily demonstrated, by prior use, to be suitable and durable for such purposes. The geomembrane shall be high

density virgin polyethylene (HDPE) containing no fillers, chemical additives, or extenders. Materials used should be free from gels, streaks, particles of foreign matter, and undispersed constituents. There should be no physical defects such as holidays, cracks, tears, or blisters.

Two to 3 percent carbon black shall be added to the resin for ultraviolet resistance. The geomembrane shall be supplied in rolls which shall have a minimum width of 15 feet. The roll length shall be maximized to provide the largest manageable sheet for the fewest field seams. Rolls of HDPE geomembrane shall be identified such that the roll numbers, resin lot numbers, and batch numbers used to make each roll and panel will be traceable.

All geomembrane specifications shall be met on a minimum average roll value (MARV) basis by the manufacturer.

2. *Geomembrane Materials.*

- a. Resin Properties: The resin shall be high density polyethylene (HDPE) and shall be new, first quality, compounded and manufactured specifically for producing HDPE geomembrane. The resin shall not consist of mixed resin types or more than 2 percent reprocessed material. The resin shall meet the following requirements:

Property	Test Method	Units	Value
Melt Flow Index (max.)	ASTM D 1238	g/10 min	21.0
Oxidative Induction Time (@ 200° C, 1 atm. O2)	ASTM D 3895	Minutes	>140

- b. Geomembrane Sheet Properties: The HDPE geomembrane sheeting shall be manufactured to meet the following requirements:
 - (1) Do not exceed a combined maximum total of 1 percent by weight of additives other than carbon black. Identify percentage of processing aids, antioxidants, and other additives other than carbon black.
 - (2) Do not exceed 3.5 percent by weight of finished HDPE-FML for total combined processing aids, antioxidants, carbon black, and other additives.
 - (3) Use materials produced in the United States or Canada.
 - (4) Provide finished product free from holes, pin holes, bubbles, blisters, excessive gels, undispersed resins and/or carbon black, contamination by foreign matter and nicks or cuts on edges.
 - (5) Both sides of the textured geomembrane shall be textured.

Physical properties of the HDPE geomembrane shall meet the following requirements:

Property	Test Method	Units	Geomembrane Min Average Value
Type of Finish			Textured
Core Thickness (min. avg.)	ASTM D5994	Mils	57
Density	ASTM D792, Method B	g/cm ³	0.94
Carbon Black Content	ASTM D4218	%	2-3
Carbon Black Dispersion	ASTM D5596	Category	1 or 2
Tensile Properties:	ASTM D 6693		
Tensile Strength at Yield		ppi	132
Tensile Strength at Break		ppi	115
Elongation at Yield		%	12
Elongation at Break		%	200
Tear Resistance	ASTM D 1004	lb.	45
Puncture Resistance	ASTM D 4833	lb.	120

3. *Extrusion Resin/Typical Extrudate.* Extrusion resin/typical extrudate used for extrusion welding of the geomembrane shall be HDPE produced from similar batch lot material as the sheet resin. Physical properties shall be the same as the geomembrane sheet. The extrudate's additives shall be thoroughly dispersed throughout the rod or bead. The extrudate shall be free of contamination by moisture and foreign matter and shall be recommended for use with the associated sheet material.
4. *Manufacturer Source Quality Control.* Perform the following quality control tests at the manufacturing plant for the HDPE geomembrane product.

<u>Property</u>	<u>Test Method</u>	<u>Frequency</u>
Thickness (minimum)	ASTM D5994	per roll
Density	ASTM D792, Method B	(2)
Carbon Black Content	ASTM D4218	(2)
Carbon Black Dispersion	ASTM D5596	(2)
Tensile Properties:	ASTM D6693	
Tensile Strength at Yield		(2)
Tensile Strength at Break		(2)
Elongation at Yield		(2)
Elongation at Break		(2)
Tear Resistance	ASTM D1004	(2)
Puncture Resistance	ASTM D4833	(2)

Notes:

- (1) One per 100,000 square feet of sheet produced or one per resin batch, whichever results in the greatest number of tests.
- (2) One per 50,000 square feet or one per resin batch, whichever results in the greater number of tests.
- (3) Certification only required.

D. Construction

1. *Panel Marking, Packaging, Delivery, Storage and Handling*

- a. General: The HDPE geomembrane shall be delivered, stored and handled in strict accordance with the manufacturer's recommendations.
- b. Marking, Packaging: Each roll of the geomembrane shall be given prominent, unique, indelible identifying markings indicating the sheet number, date of fabrication, and proper direction of unrolling to facilitate layout and positioning in the field. Each roll shall be individually packaged and protected to prevent damage to it during shipment. Packaging shall be prominently identified in the same fashion as the sheet within, and show the date of shipment.
- c. Delivery: Geomembrane shall be shipped in rolls and protected with an outside covering. Folded HDPE geomembrane shall not be accepted. Any evidence of folding shall be cause for rejection of the material by the Engineer.

Materials shall be delivered to the site only after the Engineer reviews and takes no exception to the materials and manufacturer data submitted by Contractor.

- d. Storage: The geomembrane storage area at the construction site shall be prepared, and reviewed for acceptability prior to the arrival of any material. The area shall be secured from the following:
 1. Man or Animal: The storage area shall not be near or adjacent to areas frequented by the general public, unless a security fence is provided.
 2. Puncture, Dirt, Dust, Grease or Water: Contractor shall store HDPE geomembrane rolls to protect from puncture, dirt, grease, water, moisture, water, mud, mechanical abrasions or other damage. Do not store where bonding may occur.

3. No field seaming shall be performed in the presence of precipitation, dust in the air, and/or excessive wind.
- b. Seam Welding Personnel: Provide at least one (1) liner superintendent who has experience welding over 5,000,000 square feet of HDPE using the same type of welding apparatus and material in use at the site.
- Qualify personnel performing welding operations by experience as described in these specifications and by successfully passing field welding tests performed onsite. Liner superintendent will provide direct supervision over other welders.
- c. Trial Seams: Test welds should always be prepared and tested before seaming in order to gauge appropriate welding conditions.
- Trial seams shall be made on fragment pieces of geomembrane to verify that seaming conditions and equipment are adequate. Such trial seams shall be made at the beginning of each seaming period (start of day, midday, and anytime equipment is turned off and allowed to cool down) for each seaming apparatus used. Trial seams shall be made under the same conditions as actual seams.
- The trial seam sample shall be approximately 3 feet long by 1 foot wide (after seaming) with the seam centered lengthwise. Seam overlap shall be nominally 4 inches; 3 inches minimum.
- Two (2) adjoining specimens each 1 inch (25 mm) wide, shall be cut from the trial seam sample by the Installer. The specimens shall be tested respectively in shear and peel using an Installer supplied field tensometer, and they shall not fail in the seam. If the specimen fails, the entire operation shall be repeated. If the additional specimen fails, the seaming apparatus and seamer shall not be accepted and shall not be used for seaming until the deficiencies are corrected and two (2) consecutive successful full trial welds are achieved.
- d. Seaming Equipment: Field seaming shall be performed using extrusion welding and fusion (hot wedge) welding apparatus.
- The extrusion welding apparatus shall be equipped with gauges giving the temperature of the apparatus at the nozzle and extruder barrel.
- The fusion-welding apparatus shall be an automated vehicular mounted device which produces a double seam with an enclosed air space. The fusion-welding apparatus shall be equipped with gauges giving the applicable temperatures.
- The installer shall verify and ensure that:
- Equipment used for seaming is not likely to damage geomembrane;
 - The extrusion welder is purged prior to beginning a seam until all heat-degraded extrudate has been removed from the barrel;
 - The electric generator is placed on a smooth base such that no damage occurs to the geomembrane and that the power source is capable of providing constant voltage under combined line load.
 - Buffing and grinding shall be completed no more than one (1) hour prior to extrusion welding (buffing is not necessary for hot wedge welding);
 - A smooth insulating plate or fabric is placed beneath the hot welding apparatus after usage; and
 - The geomembrane is protected from damage in heavily trafficked areas.
- e. Seaming Procedures:
- All major seams shall be performed using a double hot wedge welder. Extrusion welding shall be used only on cap strips, butt seams, and berm details.

Seaming of the geomembrane shall be performed by a certified welder using the manufacturer recommended welding system, equipment, and techniques. All field seams will be performed on a firm foundation with a supporting smooth surface.

The panels of geomembrane shall be overlapped by a minimum of 4 inches for hot wedge welding and 3 inches for extrusion welding.

Provide adequate material on weld to allow peel testing of both sides of double wedge weld. Inadequate overlaps which do not allow for peel testing shall be repaired by a capstrip.

All cross seams are to be extrusion welded where they intersect. The top flap of geomembrane shall be removed in the area to be extrusion welded and the weld area shall be ground parallel to the seam prior to welding.

If necessary, the Installer shall provide a firm substrata by using a flat board, a conveyor belt, or similar hard surface directly under the weld overlap to achieve firm support. For hot wedge welding, a movable protective layer of plastic may be required to be placed directly below the overlapped membranes being seamed.

The contact surfaces of the sheets shall be wiped clean to remove all dirt, dust, moisture, or other foreign materials prior to welding.

The Installer shall cut fishmouths or wrinkles along the ridge of any wrinkle that is to be repaired in order to achieve a flap overlap. Extrusion weld the cut fishmouths or wrinkles where the overlap is more than 3 inches. When there is less than 3 inches overlap, patch with an oval or round patch extending a minimum of 8 inches beyond the cut in all directions.

Geomembrane surface temperatures shall be recorded on both the geomembrane sheet and in the field records by the Installer at the start and finish of each weld.

Seaming shall extend up the panels to the outside edge and to the bottom of the anchor trench.

All bonded seams and joints, on completion of work, shall be sealed smooth, and provide a bonded seam with tensile and peel strength in accordance with these specifications.

Any geomembrane surface showing injury due to scuffing, penetration by foreign objects, or distress from rough subgrade shall be replaced, or covered and sealed with an additional layer of the geomembrane.

8. *Anchor Trenches:* The geomembrane anchor trenches shall be constructed in accordance with the drawings. The geomembrane anchor trench shall be left open until seaming in that particular area is completed. Expansion and contraction of the geomembrane shall be accounted for in the geomembrane placement.
9. *1/2-inch CDX Exterior Plywood:* 1/2-inch CDX Exterior Plywood shall be furnished and installed on the east perimeter of the Cell 9 Containment Berm at the location shown on the Drawings.
10. *Cover Material Placement.* Cover material shall be placed on the geomembrane by dumping rather than blading so that no tensile forces are transmitted to the geomembrane. Under no circumstances shall wheeled or tracked equipment be allowed on the geomembrane without at least 12 inches of cover.

Initial cover material shall be placed up slope wherever possible. No probes for checking the depth of cover over the HDPE shall be used. No permanent depth markers shall be used on the HDPE unless approved by the Engineer.

Cover material shall be placed so as to minimize the formation of wrinkles in the geomembrane. Wrinkles over 2 inches high shall be cut out and repaired in accordance with this Section prior to cover placement. Under no circumstances will cover material be allowed to be placed over folded geomembrane. Areas of folded material shall be cut out and repaired in accordance with this Section prior to cover placement. Drainage Layer material placement shall be in accordance with Section 02305.

Placement of cover material shall only be performed when geomembrane surface temperatures are less than the geomembrane surface temperatures were when the geomembrane was welded. The geomembrane is extremely sensitive to changes in temperature. Increases in temperature will cause the length and width of each individual sheet to expand significantly, and will cause a wave to be formed in the geomembrane during placement of the cover material.

11. Field Quality Control

- a. General: Geomembrane testing shall be performed in accordance with the following requirements.
- b. Conformance Testing:
 - 1) Perform Conformance Testing on HDPE geomembrane.
 - 2) The Installer shall obtain one sample per 100,000 square feet and per every resin lot of material supplied. Engineer shall identify where samples are to be taken.
 - 3) The Installer shall forward samples to Geosynthetic Quality Assurance Laboratory.
 - 4) The GQA Laboratory shall perform the following tests.
 - Density: ASTM D792, Method B
 - Sheet Thickness: ASTM D5994
 - Tensile Properties: ASTM D6693
 - Tear Resistance: ASTM D1004
 - Carbon Black Content: ASTM D4218
 - Carbon Black Dispersion: ASTM D5596
 - 5) Sampling Procedures:
 - Sample across the entire width of the roll excluding the first 3 feet.
 - Cut sample 3 feet by the width of the roll.
 - Mark machine direction of the roll on the sample.
- c. Non-Destructive Field Testing (performed by Installer):
 - 1) General: The Installer shall non-destructively test all field seams over their full length using a vacuum test unit or air pressure (for double fusion seams only) methods. Perform testing within twenty-four (24) hours of the time that each field seam was completed. Complete all required repairs in accordance with this Specification. Testing shall be performed in the presence of the CQA monitor.
 - 2) Vacuum Testing Equipment:
 - A vacuum box assembly consisting of a rigid housing, a transparent viewing window, a soft neoprene gasket attached to the bottom, port hole, or valve assembly, and a vacuum gauge.
 - A vacuum pump assembly equipped with a pressure control.
 - A rubber pressure/vacuum hose with fittings and connections.
 - A soapy solution and an applicator.
 - 3) Vacuum Test Procedures:
 - The CQA monitor shall be present during vacuum testing of seams.
 - Place the box over the wetted seam area (soapy solution).

- Ensure that a leak-tight seal is created.
 - Energize the vacuum pump and reduce the vacuum box pressure to approximately 10 inches of mercury (i.e., 5 psi gauge).
 - Examine the HDPE through the viewing window for the presence of soap bubbles for a period of not less than ten (10) seconds.
 - Where soap bubbles appear mark and repair in accordance with repair procedures described in this Specification.
- 4) Air Pressure Testing Equipment:
- An air pump (manual or motor driven), equipped with a pressure gauge, capable of generating and sustaining a pressure over 70 psi and mounted on a cushion to protect the HDPE.
 - A rubber hose with fittings and connections.
 - A sharp hollow needle, or other pressure feed device.
 - A pressure gauge with an accuracy of 1 psi.
- 5) Air Pressure Test Procedure:
- Seal both ends of the welded seam to be tested.
 - Insert needle or other pressure feed device into the channel created by the weld.
 - Energize the air pump to a minimum pressure of 60 psi. Allow a five (5) minute relaxing period to equilibrate channel. Sustain pressure for at least an additional five (5) minutes.
 - If loss of pressure exceeds 6 psi, or does not stabilize, locate faulty area and repair in accordance with repair procedures described in this Specification.
 - Puncture opposite end of seam to release air. If blockage is present, locate and test seam on both sides of blockage.
 - Remove needle or other pressure feed device and seal the penetration holes.
- d. Destructive Seam Testing (performed by the Installer).
- 1) Location and Frequency of Testing:
- Collect destructive test samples at a minimum frequency of one (1) test location per 500 feet of seam length or one (1) per seam, whichever results in the larger amount of samples.
 - Determine test locations after seam bonding. Locations may be prompted by suspicion or excess crystallinity, contamination, offset welds, or suspected defect. The CQA monitor will be responsible for choosing the locations. The CQA monitor will not notify Installer in advance of selecting locations where weld samples will be taken.
 - The CQA monitor may increase the test frequency at his/her discretion.
- 2) Sampling Procedures:
- The Installer shall cut samples at locations designated by the CQA monitor as the welding progresses in order to obtain laboratory test results before the HDPE is covered by another material and within twenty-four (24) hours of the request or seam welding.
 - The Installer shall number each sample and mark sample number and location.

- 3) Immediately repair all holes in the HDPE resulting from destructive sampling. Repair in accordance with repair procedures described in these specifications. Test the continuity of the repair in accordance with these specifications.
 - 4) Size of Samples: Minimum 12 inches wide by 44 inches long with the seam centered lengthwise. Cut a 1-inch wide strip from each end of the sample and test for bonded seam strength in the field. Cut the remaining sample into three (3) parts for distribution as follows:
 - One (1) portion for the Installer: 12 inches by 12 inches.
 - (1) portion for the Geosynthetic Quality Assurance Laboratory testing: 12 inches by 18 inches.
 - One (1) portion to the Owner for archive storage: 12 inches by 12 inches.
 - 5) Field Testing:
 - Test the two (2) 1-inch wide specimens using a tensiometer for bonded seam strength and peel adhesion.
 - Test specimens must meet bonded seam strength and peel adhesion requirements for bonded seams specified in this specification.
 - If any field test specimen fails, follow procedures outlined in this specification.
- e. Laboratory Testing by Geosynthetic Quality Assurance Laboratory:
- 1) Test bonded seam strength (ASTM D 3083).
 - 2) Test peel adhesion (ASTM D 413).
 - 3) Test at least five (5) specimens for each test method. Select specimens alternately by test from the samples (i.e., peel, shear, peel, sheer...). For double wedge welded samples, test both sides in peel.
 - 4) A sample passes when four (4) of the five (5) specimens for each test method meet the following requirements:
 - The break is a film tearing bond (FTB).
 - The break is ductile.
 - The peel strength is 70 percent minimum of the specified sheet strength at yield for wedge welded or flat welded seams and 60 percent minimum of the specified sheet strength at yield for extrusion welded seams.
 - The shear strength is 90 percent minimum of the specified strength at yield for all welded seams.
 - 5) Provide test results no more than forty-eight (48) hours after receiving samples.
- f. Failed Seam Procedures:
- 1) Follow these procedures when there is a destructive test failure. These procedures apply when test failure is identified by the Geosynthetic Quality Assurance Laboratory or by field tensiometer. Follow one (1) of the following two (2) options:
 - First Option: Recap the seam between any two passed test locations.
 - Second Option:
 - Trace the seam to a location at least 10 feet or to where welded seam ends, in both directions from the failed test location.
 - Obtain a small sample at both locations for an additional field test.
 - If these additional test samples pass field tests, then take laboratory samples.

- If the laboratory samples pass, then recap the seam between the test sample locations.
- If any sample fails, then repeat the process to establish the zone in which the seam must be recapped.

g. Acceptable Bonded Seams:

- 1) Bounded by two (2) locations from which samples have passed destructive tests and seam has been repaired as required by this Specification.
- 2) For recapped seams exceeding 50 feet, a sample taken from within the recapped seam passes destructive testing.
- 3) Whenever a sample fails, provide additional testing for seams that were welded by the same welder, welding apparatus or welded during the same time shift.
- 4) No seam can be recapped more than two (2) times. The HDPE sheet will then be considered damaged and shall be replaced with acceptable HDPE material.

12. Repair Procedures

- a. Remove damaged HDPE and replace with acceptable HDPE materials if damage cannot be satisfactorily repaired.
- b. Repair any portion of the HDPE geomembrane that has had a sample removed, exhibited a flaw, failed a destructive test or failed a non-destructive test. Installer shall be responsible for repair of damaged or defective areas. Agreement upon the appropriate repair method shall be decided between the Engineer and the Installer. Do not commence welding on geomembrane until trial weld test sample, made by that equipment and operator, passes trial test. Repair procedures available include:
 - 1) Patching: Used to repair all holes, tears, undispersed raw materials, and contamination by foreign matter.
 - 2) Abrading and Re-Welding: Used to repair small sections of seams.
 - 3) Spot Welding or Seaming: Used to repair pin holes or other minor, localized flaws such as where HDPE thickness has been reduced by more than 4 mils by over abrading, etc.
 - 4) Capping: Used to repair large lengths of failed seams.
 - 5) Removing the seam and replacing with a strip of new material.
- c. Patching Procedures:
 - 1) Abrade HDPE surfaces to be repaired (extrusion welds only) no more than one (1) hour prior to the repair.
 - 2) Clean and dry all surfaces at the time of repair.
 - 3) The repair procedures, materials, and techniques shall be accepted in advance of the specific repair by the Engineer.
 - 4) Extend patches or caps at least 8 inches beyond the edge of the defect, and round all corners of material to be patched and the patches to a radius of at least 3 inches. Bevel top edges of patches before extrusion welding.
 - 5) Unless otherwise instructed by the CQA monitor, cut HDPE below large caps to avoid water collection between the sheets.
- d. Verification of Repair:
 - 1) Number and log each repair.
 - 2) Non-destructively test each repair using methods specified in this Specification.

- 3) Destructive tests may be required at the discretion of the CQA monitor and will be at the Contractor's expense.
- 4) Reconstruct repairs until tests indicate passing results.
- 5) Technician making repairs shall initial each repair.
- 6) The CQA monitor shall initial each repair upon acceptance.

13. *Post Installation Inspection.* Upon completion of the installation of the geomembrane, representatives of the Installer, Contractor, and Engineer shall jointly inspect the geomembrane to satisfy themselves that material, factory seams, field seams, repairs, fitments, and anchors are in accordance with these specifications.

Following inspection, the Installer shall furnish the Engineer with certification that the geomembrane was installed in accordance with the manufacturer's recommendations.

14. *HDPE Geomembrane Acceptance.*

- a. Contractor retains all ownership and responsibility for the HDPE geomembrane until acceptance by the Engineer.
- b. The HDPE geomembrane installation shall be accepted by the Engineer when:
 - 1) Conformance test results meet project specifications.
 - 2) All required documentation from the manufacturer, installer and laboratory has been reviewed.
 - 3) The installation is finished.
 - 4) Verification of the adequacy of all field seams and repairs, including associated testing, is complete.
 - 5) Written certification documents from the Installer, including record drawings, have been reviewed by the Engineer.

E. Measurement and Payment. Measurement and payment for Geomembrane shall be in accordance with Section 01150 and the following:

1. *Measurement:* Shall be measured by the square foot (SF) of surface area covered, in place, complete, limited to the dimensions shown on the drawings, and where ordered by the Engineer. Measurements shall be made on material actually in place as measured normal to the slope. Where multiple layers of geomembrane are shown on the drawings, each layer shall be measured. No allowance shall be made for the overlapping or splicing that is required for seaming.
2. *Payment:* Shall be paid for at the applicable contract unit price, payment for which shall constitute full compensation for furnishing and installing the Geomembrane including: anchor trench excavation and backfill; exposing the geomembrane for connections to previous refuse cell liner systems; storage; seaming; repairs; CDX plywood; weather protection and testing; as well as performing all other work and incidentals necessary to provide the Geomembrane as shown on the drawings and described in the specifications.

Section 02313 - Geotextile

A. Description.

1. *General.* The work described in this Section shall consist of providing all operations pertaining to the furnishing, installing and testing of the geotextile in accordance with the specifications and in conformity with the lines and grades shown on the drawings and as directed by the Engineer.
2. Definitions.
 - a. Construction Quality Assurance (CQA) Monitor: The site representative for the Engineer.
 - b. Geosynthetic Quality Assurance Laboratory (GQAL): The party, retained by the Contractor, independent from the Owner, manufacturer, and installer, responsible for conducting tests on geosynthetic samples obtained at the site.
 - c. Geotextile Manufacturer: The party responsible for the production of the geotextile rolls from resin and for the quality of the resin.
 - d. Installer: The party responsible for field handling, storing, deploying, overlapping, on-site testing, temporary restraining (against wind), and other site aspects of the geosynthetics installations, including geomembranes, geotextiles, and geonet composites.
 - e. Panel: The unit area of geotextile that will be seamed in the field. A panel may be identified as a roll or a portion of a roll.

B. Submittals. Unless otherwise noted, submittals shall be made before commencing work specified in this Section. Copies of the following information and material shall be provided in accordance with Section 01340 of the specifications.

1. *Product Data and Factory Test Results.* Published product properties, specifications and seaming techniques for the proposed geotextile, including, but not limited to roll information, as well as factory test results of materials, certified by the geotextile manufacturer shall be submitted showing conformance with the requirements of these specifications.
2. *Quality Assurance/Quality Control.* The manufacturer's plan for quality assurance/quality control shall be submitted to the Engineer for review. The plan shall address each item in the material specification and address procedures for quality control.
3. *Delivery, Storage and Handling Instructions.* The manufacturer's recommendations for delivery, storage and handling shall be submitted to the Engineer for review.
4. *Interface Friction Angle Test Results.* Interface friction angle test results that are in accordance with Section 02110 of these Specifications.
5. Installation Drawings, Procedures and Schedules.
 - a. Installation drawings, procedures, and a schedule for carrying out the work shall be provided by the Contractor to the Engineer.
 - b. Procedures addressed by the Contractor shall include, but not be limited to, material unloading, storage, installation, repair, and protection to be provided in all types of weather. A schedule showing the order of placement, location of panels and seams shall be submitted for the Engineer's review.

C. Materials.

1. *General.* The materials supplied under these Specifications shall consist of new, first quality products, designed and manufactured specifically for the purpose of this work, which shall have been satisfactorily demonstrated, by prior use, to be suitable and durable for such purposes.

All geotextile specifications shall be met on a minimum average roll value (MARV) basis by the Manufacturer.

2. *Cushioning Geotextile Physical Properties*

Cushioning Geotextile shall be a pervious sheet of polyester or polypropylene fibers, oriented into a stable network so that the fibers retain their relative position with respect to each other. The finished edge of the geotextile parallel to the machine direction shall be finished so that the outer fibers are prevented from pulling away from the fabric. The geotextile shall be composed of continuous filament or staple fibers held together through needle punching. Needle detecting devices shall be used prior to roll-up and shipment to minimize the presence of broken needles in the final product.

Thread used to sew geotextiles shall be high strength polypropylene, polyester or Kevlar thread. Nylon threads will not be allowed. Thread color shall contrast with the geotextile being sewn so that the stitches will be visible for inspection. The thread shall be resistant to ultraviolet radiation.

The cushioning geotextile shall be non-woven fabric. Physical properties for the cushioning geotextile shall be as follows:

<u>Property</u>	<u>Test Method</u>	<u>Units</u>	<u>Min Average Roll Value</u>
Weight	ASTM D5261	oz/yd ²	16.0
Thickness	ASTM D5199	mils	175
Grab Tensile	ASTM D4632	lb	390
Grab Elongation	ASTM D4632	%	50
Puncture Resistance	ASTM D6241	lb	1125
Trapezoidal Tear	ASTM D4533	lb	145
Apparent Opening Size	ASTM D4751	US Sieve #	100

3. *Separating Geotextile Physical Properties.* The separating geotextile shall be woven monofilament polypropylene fabric. Physical properties for the separating geotextile shall be as follows:

<u>Property</u>	<u>Test Method</u>	<u>Units</u>	<u>Min Average Roll Value</u>
Grab Tensile (W/F)	ASTM D4632	lb	365/200
Grab Elongation (W/F)	ASTM D4632	%	24/10
Trapezoidal Tear (W/F)	ASTM D4533	lb	115/75
CBR Puncture Strength	ASTM D6241	lb	675
Permittivity	ASTM D4491	sec ⁻¹	2.1
Apparent Opening Size	ASTM D4751	US Sieve #	40
UV Resistance (500 hrs)	ASTM D4355	%	90
Water Flow	ASTM D4491	gpm/sq ft	100
Open Area	COE-02215	%	10

4. *Manufacturer Source Quality Control.*

- a. Test the geotextile at a minimum of once for every 100,000 square feet produced or each lot provided, whichever results in the greater number of tests, to evaluate the pertinent characteristics for quality control. If testing does not meet the specifications the Engineer shall reject the applicable rolls. At the manufacturers' discretion and expense, additional testing of individual rolls may be performed to more closely identify the non-complying rolls and/or to qualify individual rolls.

- b. Certify the quality of the rolls of geotextiles. Provide quality control certificates for each lot and each shift's production in accordance with this Section. Include the following:
 - 1) Roll numbers and identification.
 - 2) Sampling procedures.
 - 3) Results of quality control tests, including a description of test methods used.

5. *Labeling.*

- a. Each roll shall be wrapped in impermeable and opaque protective covers prominently and indelibly marked or tagged with the following information:
 - 1) Manufacturer's name.
 - 2) Product identification.
 - 3) Lot number.
 - 4) Roll number.
 - 5) Roll dimensions.
- b. If any special handling is required, mark special handling requirements on the geotextile itself, e.g., "This side up", or "This side against geomembrane". Overlap guidelines shall be marked on the geotextile. The rolls of geotextile shall be identified such that the roll numbers, lot numbers and product identification allow each roll to be traceable.

D. Construction.

1. *Panel Marking, Packaging, Delivery, Storage and Handling.*

- a. General: The geotextile shall be delivered, stored and handled in strict accordance with the Manufacturer's recommendations.
- b. Packaging: Each factory roll shall be individually packaged and protected to prevent damage to it during shipment. It shall be prominently identified in the same fashion as the roll within, and show the date of shipment.
- c. Delivery: Materials shall be delivered to the site only after the Engineer reviews and takes no exception to the materials and Manufacturer submitted by Contractor.
- d. Storage: The geotextile storage area at the construction site shall be prepared by the Contractor and reviewed for acceptability prior to the arrival of any material. The area shall be secured from the following:
 - 1) Puncture, Dirt, Dust, Grease or Water: Store geotextile rolls to protect from puncture, dirt, grease, water, moisture, water, mud, mechanical abrasions or other damage. Do not store where bonding may occur.
 - 2) Extreme Heat - The geotextile shall be protected from direct sunlight and extreme heat.
- e. Handling: Use appropriate handling equipment recommended by the Manufacturer to load, move, and deploy geotextile rolls. Appropriate handling equipment may include, but not be limited to, cloth chokers, spreader bar, and roll bars for deployment. Dragging panels or rolls on ground surface will not be permitted.

Contractor is responsible for off-loading, storage, and transporting material from storage area to installation site.

- 2. *Preparation.* Excavate anchor trenches prior to deployment. Round edges of anchor trench.

3. *Installation of Geotextile.*

- a. The geotextile shall be placed in such a manner as to assure minimum handling. Extreme care shall be taken to protect the underlying materials. The geotextile shall be installed as shown on the drawings and in accordance with the reviewed panel placement plan.
- b. Any portion of the geotextile damaged during installation shall be removed and repaired in accordance with these Specifications.
- c. Should any underlying materials be damaged during the installation of the geotextile, the underlying materials shall be repaired in accordance with their respective specifications.
- d. Assign each panel an identifying code number or letter consistent with the Contractor's submitted panel layout drawing.
- e. Deploy no more panels in one (1) shift that can be secured during that same day.
- f. Do not allow vehicular traffic directly on the geotextile.
- g. Do not damage the geotextile by handling, by traffic, or any other means. Do not smoke, wear damaging shoes or engage in activities that could damage the geotextile.
- h. On slopes greater than 20 percent, securely anchor in an anchor trench and then roll down slope keeping the geotextile sheet in sufficient tension to preclude folds and wrinkles.
- i. If in place, special care must be taken to protect other geosynthetic materials from damage which could be caused by the cutting of the geotextiles.
- j. During placement, do not entrap stones, excessive dust, or moisture that could damage the geotextile, negatively impact the geotextile's intended use, or hamper subsequent seaming.
- k. Examine the geotextile over the entire surface, after installation, to ensure that no potentially harmful foreign objects, such as needles, are present. Remove any foreign objects encountered.
- m. If white colored geotextile is used, protect personnel against "snow blindness".

4. *Overlaps and Field Seams.*

- a. Orient overlaps parallel to the line of maximum slope, (i.e., down, not across slope). Keep horizontal overlaps (overlaps running perpendicular to the slope line) at least 5 feet away from toe or crest of slope. Minimize the number of overlaps in the corners, odd-shaped geometric locations and outside corners. The overlaps shall be identified with a numbering/labeling system that is compatible with the panel identification system.
- b. Overlap geotextile in accordance with manufacturer recommendations for seams. Do not place horizontal seams on side slopes.
- c. Ensure that no cover material could be inadvertently inserted beneath the geotextile at the overlaps.
- d. Heat fusion welding or a flat or prayer seam (Type SSa-2) with two rows of stitches, shall be used for all geotextile seams including repair of damaged in-place geotextile. The shear strength shall be 50 percent minimum of the specified grab tensile strength for all welded or sewn seams. The minimum distance from the edge of the geotextile to the nearest stitchline shall be one and one-half (1-1/2) inch. The stitch type shall be "401" Two Thread Chainstitch. There shall be a minimum of 3 stitches per inch per row.
- e. Separating geotextile shall be seamed in accordance with manufacturer recommendations.

5. *Anchor Trench.* The anchor trench shall be left open until all seaming (GCL, geomembrane, geotextile) in that particular area is completed.

6. *Sand Bag Ballasting.* Sand bags shall be placed 10-feet on-center each way over the portions of the Separating Geotextile that are exposed at the completion of the work. In addition, a row of sand bags shall be placed 5-foot on-center around the Separating Geotextile perimeter.

2. *Payment:* Shall be paid for at the applicable contract unit price, payment for which shall constitute full compensation for anchor trench excavation and backfill, furnishing and installing geotextile, storage, seaming, repairs, weather protection and testing as well as performing all other work and incidentals necessary to provide the geotextile as shown on the drawings and described in the Specifications.

Section 02314 – Geonet Composite

A. Description.

1. *General.* The work described in this Section shall consist of providing all operations pertaining to the furnishing, installing and testing of the geonet composite in accordance with the specifications and in conformity with the lines and grades shown on the drawings and as directed by the Engineer.
2. *Definitions*
 - a. Construction Quality Assurance (CQA) Monitor: The site representative for the Engineer.
 - b. Geosynthetic Quality Assurance Laboratory (GQAL): The party, retained by the Contractor, independent from the Owner, manufacturer, and Installer, responsible for conducting tests on geosynthetic samples obtained at the site.
 - c. Geonet Composite Manufacturer: The party responsible for the production of the geonet composite rolls from resin and for the quality of the resin.
 - d. Installer: The party responsible for field handling, storing, deploying, overlapping, tying, on-site testing, temporary restraining (against wind), and other site aspects of the geosynthetics installations, including geomembranes, geotextiles, and geonet composites.
 - e. Panel: The unit area of geonet composite that will be seamed in the field. A panel may be identified as a roll or a portion of a roll.

B. Submittals. Unless otherwise noted, submittals shall be made before commencing work specified in this Section. Copies of the following information and material shall be provided in accordance with Section 01340 of the specifications.

1. *Product Data and Factory Test Results.* Published product properties, specifications and joining techniques for the geonet composite, including, but not limited to roll information and factory test results that are certified by the geonet composite manufacturer and which show conformance with the requirements of these specifications. In addition, the Contractor shall submit the manufacturer's certification stating that the material proposed is similar to and of the same formulation as that for which test results are submitted, and by which actual usage has been demonstrated to be satisfactory for the intended application.
2. *Quality Assurance/Quality Control.* The manufacturer's plan for quality assurance/quality control shall be submitted to the Engineer for review. The plan shall address each item in the material specification and address procedures for quality control.
3. *Delivery, Storage and Handling Instructions.* The manufacturer's recommendations for delivery, storage and handling shall be submitted to the Engineer for review.
4. *Interface Friction Angle Test Results.* Interface friction angle test results that are in accordance with Section 02110 of these Specifications.
5. Installation Drawings, Procedures and Schedules.
 - a. Installation drawings, procedures, and a schedule for carrying out the work shall be provided for review.
 - b. Procedures addressed by the Contractor shall include but not be limited to material unloading, storage, installation, tying methodology, and repair.

C. Materials

1. *General.* The materials supplied under these specifications shall consist of new, first quality products, designed and manufactured specifically for the purpose of this work, which shall have been satisfactorily demonstrated, by prior use, to be suitable and durable for such purposes. The geonet composite shall be manufactured by heat bonding needle punched, non-woven, continuous filament or staple fiber polyester geotextiles to two sides of a geonet core.
2. *Geonet Composite Properties.* Properties for the geonet composite shall be as follows:

Property	Test Method	Units	Value
Geocomposite			
Transmissivity	ASTM D4716	m ² /sec	7 x 10 ⁻⁴
Ply Adhesion	ASTM D7005	lb/in	1.0
Geonet Component			
Density	ASTM D792, Method B	g/cm ³	0.94
Thickness	ASTM D5199	mils	275
Tensile Strength	ASTM D7179	lbs/in	65
Geotextile Component			
Fabric Weight	ASTM D 5261	oz/yd ²	8.0
Grab Strength	ASTM D 4632	lbs	220
CBR Puncture Strength	ASTM D 6241	lbs	575
Water Flow Rate	ASTM D 4491	gpm/ft ²	95
AOS	ASTM D 4751	Sieve Size	80

All geonet composite specifications shall be met on a minimum average roll value (MARV) basis.

3. *Manufacturer Source Quality Control.*

Certify the quality of the rolls of geonet composite. Provide quality control certificates for each lot and each shift's production in accordance with this Section. Include the following:

- 1) Roll numbers and identification.
- 2) Sampling procedures.
- 3) Results of quality control tests, including a description of test methods used.

4. *Labeling.*

- a. Each roll shall be wrapped in impermeable and opaque protective covers and prominently and indelibly marked or tagged with the following information:
 - 1) Manufacturer's name.
 - 2) Product identification.
 - 3) Lot number.
 - 4) Roll number.
 - 5) Roll dimensions.
- b. If any special handling is required, mark special handling requirements on the geonet composite itself, such as, "This side up". Overlap guidelines shall be marked on the geonet composite. The rolls of geonet composite shall be identified such that the roll numbers, lot numbers and product identification allow each roll to be traceable.

D. Construction.

1. Panel Marking, Packaging, Delivery, Storage and Handling.

- a. General: The geonet composite shall be delivered, stored and handled in strict accordance with the manufacturer's recommendations.
- b. Packaging: Each factory roll shall be individually packaged and protected to prevent damage to it during shipment. It shall be prominently identified in the same fashion as the roll within, and show the date of shipment.
- c. Delivery: Materials shall be delivered to the site only after the Engineer reviews and takes no exception to the materials and manufacturer submitted by Contractor.
- d. Storage: The geonet composite storage area shall be prepared and reviewed for acceptability prior to the arrival of any material. The area shall be secured from the following:
 - 1) Man or Animal: The storage area shall not be near or adjacent to areas frequented by the general public, unless a security fence is provided.
 - 2) Puncture, Dirt, Dust, Grease or Water: Store geonet composite to protect from puncture, dirt, grease, water, moisture, water, mud, mechanical abrasions or other damage. Do not store where bonding may occur.
 - 3) Extreme Heat - The geonet composite shall be protected from direct sunlight and extreme heat.
- e. Handling: Use appropriate handling equipment recommended by the manufacturer to load, move, and deploy geonet composite rolls. Appropriate handling equipment may include, but not be limited to, cloth chokers, spreader bar, and roll bars for deployment. Dragging panels or rolls on ground surface will not be permitted.

2. Installation of Geonet Composite

- a. The geonet composite shall be placed in such a manner as to assure minimum handling. Extreme care shall be taken to protect the underlying materials. The geonet composite shall be installed as shown on the drawings and in accordance with reviewed panel layout drawings.
- b. Any portion of the geonet composite damaged during installation shall be removed and repaired in accordance with these specifications.
- c. The Installer shall take any necessary precautions to prevent damage to underlying layers during placement of the geonet composite. Should any underlying materials be damaged during the installation of the geonet composite, the underlying materials shall be repaired in accordance with their respective specifications.
- d. Do not allow vehicular traffic directly on the geonet composite.
- e. On slopes, the geonet composite shall be secured and rolled down the slope in such a manner as to continually keep the geonet composite sheet in tension. If necessary, the geonet composite shall be positioned by hand after being unrolled to minimize wrinkles.
- f. If in place, special care must be taken to protect other geosynthetic materials from damage which could be caused by the cutting of the geonet composite. Geonet composite shall only be cut using manufacturer recommended cutting tools that will not damage underlying geosynthetics.
- g. During placement of geonet composite, care shall be taken not to entrap dirt, excessive dust, or fugitive bentonite clay in the geonet composite that could cause clogging of the drainage system, and/or stones that could damage the adjacent geomembrane. If dirt or excessive dust is entrapped in the geonet composite, it should be cleaned prior to placement of the next material on top of it.
- h. Examine the geonet composite over the entire surface after installation to ensure that no potentially harmful foreign objects are present. Remove any foreign objects encountered.

3. *Joints and Overlaps*

The following requirements for joining the adjacent geonet composite shall be met:

- a. Adjacent rolls shall be overlapped by at least 4 inches.
- b. The geonet composite overlaps shall be tied with plastic fasteners. Tying devices shall be white or yellow for easy inspection. Metallic devices are not allowed. Tying devices shall not have any sharp corners or edges and shall be constructed such that their installation does not damage the geomembrane.
- c. Tying shall be every 5 feet along the length at the adjacent rolls and every 6 inches along end-to-end seams.
- d. When more than one layer of geonet composite is installed, joints shall be staggered.
- e. When several layers of geonet composite are stacked, rolls shall be deployed in the same direction to prevent strands of one layer from penetrating the channels of the adjacent layer.

4. *Repair Procedures:*

- a. If the hole or tear width is less than 50% of the width of the roll, the damaged area shall be repaired as follows:
 - 1) A patch shall be placed extending 1 foot beyond the edges of the hole or tear.
 - 2) The patch shall be secured to the original geonet composite by tying every 6 inches. Tying devices shall be as previously indicated.
- b. If the hole or tear width across the roll is equal to or more than 50% of the width of the roll, the damaged geonet composite shall be removed and replaced.

5. *Field Quality Control.*

- a. General: Geotextile testing shall be performed in accordance with the following requirements.
- b. Conformance Testing (performed by the GQAL):
 - 1) Obtain one (1) sample per 100,000 square feet and per every lot of material supplied. Contractor shall obtain samples at a location selected by the CQA monitor.
 - 2) Perform the following tests for confirming conformance with the Specifications.
 - Transmissivity ASTM D4716
 - Ply Adhesion ASTM D7005
 - 3) Sampling Procedures:
 - Sample across the entire width of the roll excluding the first 3 feet.
 - Sample 3 feet by the width of the roll.
 - Mark machine direction of the roll on the sample.

6. *Geonet Composite Acceptance.*

- a. The Contractor retains all ownership and responsibility for the geonet composite until acceptance by the Engineer.
- b. The geonet composite will be accepted by the Engineer when:
 - 1) The installation is finished.
 - 2) All documentation of installations is completed

- 3) Verification of the adequacy of all overlaps and repairs, including associated testing, is complete.

E. Measurement and Payment. Measurement and payment for Geonet Composite shall be in accordance with Section 01150 and the following:

1. *Measurement:* Shall be measured by the square foot (SF) of surface area covered, in place, complete, limited to the dimensions shown on the drawings, and where ordered by the Engineer. Measurements shall be made on material actually in place as measured normal to the slope. Where multiple layers of geonet composite are shown on the drawings, each layer shall be measured. No allowance shall be made for the overlapping that is required for seaming.
2. *Payment:* Shall be paid for at the applicable contract unit price, payment for which shall constitute full compensation for furnishing and installing the geonet composite, storage, seaming, repairs, weather protection and testing as well as performing all other work and incidentals necessary to provide the geonet composite as shown on the drawings and described in the specifications.

Section 02410- Landfill Gas Collection System

A. Description

General. The work under this section consists of the performance of all operations pertaining to furnishing and installing the Landfill Gas(LFG) Collection system within Cell 9, modifying the existing condensate sump south of Cell 9, and connecting into the existing header, in accordance with the drawings, these specifications, and as required by the Engineer.

B. Submittals

The Contractor shall supply all submittal information in accordance with Section 01340-Shop Drawings, Product Data, and Samples. Minimum (but not limited to) material submittal requirements will include details for:

1. Pipe and fittings,
2. Valves,
3. Gasket Material,
4. Wellheads,
5. Fasteners, and
6. Condensate sump materials and equipment.

C. Materials

1. *High-Density Polyethylene (HDPE) Pipe:*

The polyethylene pipe shall be HDPE pipe, polyethylene resin type 4710, conforming to ASTM D3350. Minimum cell classification values shall be PE345434C, as referenced in ASTM D3350. Pipe shall be SDR 11 for liquid and compressed air conveyance lines and SDR 17 for LFG conveyance lines unless otherwise requested by the County or the Engineer. SDR 11 can be substituted for SDR 17. The pipe shall contain a minimum of 2-percent carbon black.

The pipe shall contain no recycled compound except that generated in the manufacturer's own plant from resin of the same specification from the same raw material supplier.

The polyethylene pipe shall be homogeneous throughout, and free of visible cracks, holes, foreign inclusions, or other injurious defects. Any pipe with nicks, scrapes, or gouges deeper than 5 percent of the nominal wall thickness shall be rejected. The pipe shall be uniform in color, opacity, density, and other physical properties.

The following information shall be continuously marked on the pipe, or spaced at intervals not exceeding 5 feet:

1. Name and /or trademark of the pipe manufacturer
2. Nominal pipe size
3. Standard Dimensional Ratio (SDR)
4. PE 4710
5. Manufacturing Standard Reference
6. A production code from which the date and place of manufacture can be determined

Compliance of the requirements of these specifications shall be certified in writing by the pipe manufacturer and submitted in accordance with Section 01340 of these specifications.

Damaged pipe that results in a reduction of the wall thickness by more than 10-percent shall be cut out and discarded.

2. *Fittings:*

Fittings shall be butt fusion type, meeting the requirements of ASTM D3261. Fittings shall be manufactured using polyethylene resin type 4710 in accordance with the requirements of ASTM D2513. All fittings shall be

rated to match the system piping to which they are fused. Pipe connections between dissimilar materials shall be joined by stub end and backing flange.

Electro-fusion type fittings may be substituted where required when approved by the Engineer.

3. *LFG Wellheads*

LFG wellheads shall be 2" HDPE horizontal Flo-Wing with quick-connect sampling connections, electrofusion welded to 2" HDPE Polygate valve or approved equal. The valve handle and the quick-connect connections should be oriented straight-up.

4. *LFG Flexible Hosing*

LFG flexible hose shall be 2" Kanaflex Hose 101 IPS, UV resistant.

5. *Flanges:*

Flanges, when required, shall be of a plate type ANSI B16.5, Class 150 lb. Flange surfaces that require gaskets shall use Hypalon, Buna-N, Viton, or an approved equal .

6. *Fasteners:*

Bolts shall conform to the requirements of ASTM A307. Below grade bolts shall be galvanized steel, Grade B, heavy hex, hot dip zinc coated in accordance with the requirements of Class C or ASTM A153. Above grade bolts shall be stainless steel, type 304 in accordance with the requirements of ASTM F593. Nuts shall conform to the requirements of Class C or ASTM A563. Nuts shall be Grade A, heavy hex, hot dip zinc coated in accordance with the requirements of Class C ASTM A153. Washers shall be Grade A, hot dip zinc coated in accordance with the requirements of Class C of ASTM A153.

7. *Valves:*

All valves shall be complete with all necessary operators, actuators, handwheels, worm and gear operators, wrenches, and other accessories or appurtenances which are required for the proper completion of work included under this Section.

Valves shall be suitable for the intended service. Renewable parts, including discs, packing, and seats, shall be of types recommended by valve manufacturer for intended service, but not of lower quality than specified herein.

A. *Butterfly Valves:*

- 1) All valve shafts shall be connected to operators by use of keys and keyways. The use of compression or friction connection will not be accepted.
- 2) Butterfly valves shall have ductile or cast-iron full lug-style valve body with contoured 316 stainless steel disc, 316 stainless steel stem and Buna-N or Viton resilient seat. Valves shall be bubble-tight at 150 psi differential pressure and shall be suitable for installation between ANSI 150-pound flanges.
 - a) Valve body shall be lug-style if installed on header lateral, either in-line or termination point.
 - b) Valve body shall be wafer-style if installed in-line.
 - c) Valve body shall be lug-style if installed at a pipe termination point.
- 3) Valves greater than 4-inches shall have a gear operator. Valves 4-inches and less shall have a multi-position locking handle.
- 4) All butterfly valves shall open left or counterclockwise when viewed from the stem. Manual valve operators shall be either gear or lever type, or as shown on the drawings. All operators shall have mechanical stop limiting devices to prevent over travel of the disc.
- 5) Interior of valve body (except for valve disc, valve seat, and stainless steel valve seat rings) shall be coated in accordance with the latest version of AWWA C550. Coatings shall be free of imperfections

with a minimum thickness of 12 mils. Surface shall be clean, dry, and free from rust and grease before coating.

- 6) All exterior surfaces of butterfly valves shall be clean, dry and free from rust and grease coatings. The exterior ferrous parts of all valves shall be shop primed at the factory.
- 7) For all valves installed below grade, without a vault, stems shall be extended so that operation of handwheel is above grade. A housing for the stem shall be installed if necessary.
- 8) For all valves installed below grade in a vault, stems shall be extended so that operation of handwheel is within 6" of vault lid for ease of access.

B. Gate Valves:

- 1) Valves shall have replaceable disc and stem assembly.
- 2) HDPE wellhead gate valves to be two inch (2") Polygate or approved equal.

8. *Condensate Sump*

Condensate sump modifications are to be fabricated and located as per the drawings. Variation from drawings are to be approved by the Engineer.

A. Sump Reservoir

- 1) Sump reservoir and isolation well are to be custom fabricated from HDPE SDR17 or as otherwise approved.
- 2) Reservoir body to include appropriate gusset supports.

B. Sump Pump

- 1) The existing integral pump is an air operated, submersible, bottom loading liquids pump with automatic level control.
- 2) Existing pump is QED Short AP4+ Bottom Loading Aggressive Fluid Pump or approved equal.
- 3) Inlet screen, connection fittings, and internal controls are 316 stainless steel.

C. Sump Accessories

- 1) Existing removable quick cap cover is used for ease of pump removal and maintenance. Quick cap is Real Environmental or approved equal. All cap fittings are to be quick-connect style for ease of removal of the cap, pump, and associated tubing as an assembly.
- 2) Sheathed tubing is to be supplied for connection between the pump and the Quick Cap.
- 3) Existing bubbler depth measurement assembly is to be mounted so that it's easily readable from grade. The depth tubing is to be terminated near the base of the pump.

D. Sump Vault

- 1) Precast concrete vault around sump head to be Oldcastle 575-LA or equal.

D. Construction

1. *Aboveground Installation*

Thermal expansion and contraction play a critical role in above-grade installed pipes. Temperature changes both externally and internally will cause the pipe to expand or contract, and limiting and accommodating these expansions and contractions is very important.

Prior to installation of the pipe, the Contractor shall prepare grade along the pipe route to lines and grades as shown in the drawings. The grade shall be finished relatively smooth to accommodate movements of the pipe in all directions during expansion and contraction.

Pipe to be installed on the prepared grade as shown in the design drawings.

Where piping is required to be installed above grade, adequate pipe supports, anchoring, or expansion joints will be utilized to manage thermal expansion movement and minimize stress at connection fittings.

2. *Below-Ground Installation:*

Trench excavation shall be as shown on the design drawings and shall be open cut from the ground surface. Contractor most probably will encounter rock. Contractor shall complete excavation to depths specified in the drawings, regardless of conditions encountered.

Trenches shall be excavated to maintain depth and width as required to maintain minimum cover and condensate drainage slope as shown in the drawings. Where not shown, a minimum of 0.5% continuous slope is to be maintained in the direction of the condensate collection points.

Unless otherwise specified, all LFG piping shall be installed in below grade trenches with a minimum of 1-foot of cover measured from the top-of-pipe. Where required to provide a smooth grade, or if trenching is located within the refuse, a minimum of 4-inches pipe bedding shall be utilized. Bedding material shall be clean soil or as approved by the engineer.

The Contractor shall be responsible for maintaining alignment and depth of the pipeline.

When lowering pipe into the trench, prevent damage to or twisting of the pipe. Proper facilities shall be provided for lowering sections of pipe into the trenches. Under no circumstances shall pipe be laid in water, and no pipe shall be laid when the trench or weather conditions are unsuitable for such work. Diversion of drainage or dewatering of trenches during construction shall be provided as necessary.

All pipe, fittings, weld joints must be reviewed by the Engineer prior to backfilling. The Contractor shall provide timely notice (at least 2 working days in advance of backfilling) to allow time for the Engineer to arrange for necessary inspections. Backfilling will not be allowed prior to the Engineer's review. This review does not relieve the Contractor of the responsibility for protection of the pipe against damage during backfilling.

Compact all embankment and bedding material to 95 percent of Modified Proctor maximum density as defined by ASTM D 1557.

3. *Pipe Drainage Slope:*

All piping installed on or in compacted native soils shall be installed with a minimum 0.5% drainage slope unless otherwise shown in the drawings or approved by the Engineer. Slope direction is to be as shown in the drawings or as required to direct condensate within the piping system to a condensate collection point.

4. *Pipe Cutting:*

Cutting shall be done with approved mechanical equipment in a manner that will not damage the pipe. Pipe shall be firmly and uniformly supported. Pipe interior shall be kept thoroughly clean as the work progresses.

All pipe cuts shall be square, perpendicular to center of the pipe.

5. *Pipe Joining:*

Unless otherwise shown on the drawings, the HDPE pipe shall be joined by the method of thermal butt-fusion, as outlined in ASTM F2620 and PPI TR-33. Butt-fusion joining of pipe and fittings shall be performed in accordance with the procedures recommended by the manufacturer.

Thermal butt-fusion of the pipe shall be performed by an experienced technician, certified by the pipe manufacturer in the jointing of high-density polyethylene pipe, in accordance with ASTM F2620. The pipe manufacturer, or his authorized representative, shall submit descriptive information about the fusion equipment to be used, and the qualifications of the joining technician. Written certification of the individual welders shall be required prior to the performance of any welding.

The Contractor shall remove all interior debris, clean, and flush all piping prior to installation.

6. *Pipe Bending:*

Where changes in pipe alignment are required, the HDPE pipe shall be bent on a curve with a minimum radius of 50-feet.

7. *Pipe Pressure Testing:*

The Contractor shall conduct testing of installed piping, including fittings and flanges where applicable. All necessary equipment and materials are to be furnished by the Contractor.

Testing may be completed on complete lengths of piping or on isolated sections as required.

Piping joints and flanges to be backfilled are to remain exposed until completion of the associated test.

The QC Engineer shall be notified at least 48-hours in advance of testing.

The HDPE LFG conveyance piping shall be subjected to a pneumatic test of 10 psig for one hour. Pressure in the test section shall be gradually increased to the target pressure. During the observation period, the pressure should remain steady within 5-percent to indicate no leakage. Pressure readings shall be recorded at 15-minute intervals.

The Contractor and Engineer should visually inspect the piping being tested prior to applying pressure.

Ambient temperature should be monitored and limited to 10-percent variation during the testing observation period. Temperature readings shall be recorded at the same time the pressure readings are recorded.

The Contractor shall recognize the hazards associated with pneumatic testing and shall take all necessary precautions to protect test personnel. During the testing, no personnel should be allowed to walk along the test piping unless authorized by the Contractor.

During the observation period, the Contractor shall listen for any leakage and apply a liquid solution to inspect connection points and suspect portions of the piping for leaks. Leaks are to be fixed as required and the piping re-tested in the area of repair.

Upon Engineer approval the Contractor may modify the testing procedures if required due to field conditions.

Test Records shall include:

1. Date of test,
2. Description and identification of the piping tested,
3. Test pressure,
4. Remarks such as leaks or repair locations, and
5. Certification by the Contractor and signed acknowledgement by the QC Engineer.

8. *Valves:*

Valves of the size and type as shown on the drawings shall be set plumb and installed at the locations indicated or otherwise approved by the Engineer.

Valves shall be installed in accordance with the manufacture's installation instructions.

Valves shall be installed such that they are supported properly in their respective positions, free from distortion and strain. Valves shall be installed such that their weight is not borne by equipment that is not designed to support the weight of the valve.

Valves shall be tested at the same time that the associated pipeline is tested.

Valves shall be carefully inspected by the QC Engineer during installation; they shall be opened wide and then tightly closed and the various nuts and bolts shall be tested for tightness. Special care shall be taken to prevent foreign matter from becoming lodged in the valve seat. Check and adjust valves for smooth operation.

Install valves with the operating stem in either horizontal or vertical position.

Allow sufficient clearance around the valve operator for proper operation.

If the size of the disc interferes with the inside diameter of the pipe, the Contractor may order flange adapters with an ID larger than the disc diameter, to be approved by the Engineer.

E. Measurement and Payment - Measurement and payment for Landfill Gas Collection System shall be in accordance with Section 01150 and the following:

1. *Measurement*: Shall be measured by the lump sum (LS) complete and in place.
2. *Payment*: Shall be paid for at the applicable contract unit price, payment for which shall be full compensation for the Landfill Gas Collection System, in place, complete including sump extension, excavation, furnishing, hauling, assembling, pipe, valves, jointing, special fittings, joint materials, pipe bedding, testing and all incidental work and material necessary for a complete installation to the required lines and grades shown on the drawings and where ordered by the Engineer.

Section 02624 - Leachate Collection System Piping

A. Description

The work under this section consists of the performance of all operations pertaining to furnishing and installing leachate collection and cleanout piping, in accordance with the drawings, these specifications, and as required by the Engineer.

B. Materials

1. *Resin and Material Requirements.* All material shall be manufactured from a PE 4710 resin listed with the Plastic Pipe Institute (PPI) as TR-4. The resin material shall meet the specifications of ASTM D 3350 with a minimum cell classification of 445474C. HDPE pipe and fittings shall contain no recycled compounds except that generated in the manufacturer's own plant from resin of the same specification from the same raw material. HDPE products shall be homogeneous throughout and free of visible cracks, holes, foreign inclusions, voids, or other injurious defects.
2. *HDPE Pipe*
 - a. Pipe shall be made of HDPE material with a minimum material designation code of PE4710 and with a minimum Cell Classification of 445474C. The polyethylene compound shall be suitably protected against degradation by ultraviolet light by means of carbon black of not less than 2 percent. The manufacture of the HDPE resin shall certify the cell classification indicated.
 - b. Pipe sizes 3" and larger shall have a manufacturing standard of ASTM F 714, while pipe smaller than 3" shall be manufactured to the dimensional requirements listed in ASTM D 3035. Pipe shall have a working pressure exceeding 160 psi at 73.4 degrees F., and a SDR of at least 11.0.
 - c. Pipe shall meet AWWA C901 (3/4" to 3") or AWWA C906 (4" to 63"), and shall be listed as meeting NSF-61.
 - d. Perforated leachate collection piping shall consist of rows of 1/2-inch diameter holes spaced as shown on the drawings.
 - e. The Contractor shall remove all interior pipe weld beads and shall clean and flush all piping prior to installation.
 - f. The following information shall be continuously marked on the pipe, or spaced at intervals not exceeding 5 feet:
 - 1) Name and /or trademark of the pipe manufacturer
 - 2) Nominal pipe size
 - 3) Standard Dimensional Ratio (SDR)
 - 4) PE 4710
 - 5) Manufacturing Standard Reference
 - 6) A production code from which the date and place of manufacture can be determined
 - g. Compliance of the requirements of these specifications shall be certified in writing by the pipe manufacturer and submitted in accordance with Section 01340 of these specifications.
3. *HDPE Fittings*
 - a. *Butt Fusion Fittings-* Fittings shall be made of HDPE material with a minimum material designation code of PE4710 and with a minimum Cell Classification of 445474C. Fittings shall have a minimum pressure rating equal to or greater than the pipe to which they are joined unless otherwise specified on the plans or accepted by the Engineer. All fittings shall meet the requirements of AWWA C901 or C906.

- 1) Molded fittings shall comply with the requirements of ASTM D 3261.
 - 2) All fabricated elbows, tees, reducing tees and end caps shall be produced and meet the requirements of ASTM F 2206.
 - 3) Socket fittings shall meet ASTM D 2683.
- b. *Electrofusion Fittings* - Fittings shall be made of HDPE material with a minimum material designation code of PE 4710 and with a minimum Cell Classification of 445474C. Electrofusion Fittings shall have a manufacturing standard of ASTM F1055. Fittings shall have a minimum pressure rating equal to or greater than the pipe to which they are joined.
- c. *Bolted Connections*- Flanges and MJ Adapters shall be fused onto the pipe and have a minimum pressure rating equal to or greater than the pipe unless otherwise specified on the plans.
- 1) Metallic back-up rings (Van-Stone style lap joint flanges), shall have a radius on the inside diameter of the bore so as to be compatible with HDPE Flanges. Back up rings shall have bolt pattern that will mate with AWWA C207 Class D (generically known as 150 pound patterns).
 - 2) Where shown on the drawings, 4" and larger transitions to mechanical joint fittings and valves shall be accomplished using a MJ Adapter with kit. The D.I./HDPE mechanical joint adaptor shall consist of an HDPE mechanical joint transition fitting, rubber gasket, a mechanical joint backup drive ring, and Corten mechanical joint tee bolts.
- d. *Mechanical Fittings*: The use of mechanical coupling and saddles shall be approved by the owner or engineer prior to installation. Mechanical Fittings shall be designed for use and compatible with HDPE pipe, including SS stiffeners when required by manufacturer. Mechanical fittings shall have a pressure rating equal to or greater than the pipe.

C. Construction

1. *Pipe Laying*: The leachate collection piping shall be bedded as shown on the drawings.
2. *Pipe Joining*: The HDPE pipe shall be joined by the method of thermal butt-fusion, as outlined in ASTM F2620 and PPI TR-33. Butt-fusion joining of pipe and fittings shall be performed in accordance with the procedures recommended by the manufacturer.

Thermal butt-fusion of the pipe shall be performed by an experienced technician, certified by the pipe manufacturer in the jointing of high-density polyethylene pipe, in accordance with ASTM F2620. The pipe manufacturer, or his authorized representative, shall submit descriptive information about the fusion equipment to be used, and the qualifications of the joining technician. Written certification of the individual welders shall be required prior to the performance of any welding.

The test joints shall be visually examined in accordance with ASTM F2620. The Engineer reserves the right to request that five samples be cut from the pipe during the jointing process, at no additional cost to the Owner, to document the integrity of the fusion process.

The Contractor shall remove all interior pipe weld beads and shall clean and flush all piping prior to installation.

All pipe joints must be reviewed by the Engineer prior to backfilling. The Contractor shall provide timely notice (at least 1 working day in advance of backfilling) to allow time for the Engineer to arrange for necessary inspections. Backfilling will not be allowed prior to the Engineer's review. This review does not relieve the Contractor of the responsibility for protection of the pipe against damage during backfilling.

3. *Pipe Bending*. Where changes in pipe alignment are required, the HDPE pipe shall be bent on a curve with a minimum radius of 50-feet. In order to facilitate access by inspection and cleaning equipment, fittings shall not be utilized.
4. *Pipe Testing*. 8-inch pipe shall be tested by pulling a 5.0-inch mandrel through the pipe interior.

D. Measurement and Payment. Measurement and payment for 8-inch Perforated HDPE Pipe shall be in accordance with Section 01150 and the following:

1. *Measurement:* Shall be measured by the linear foot (LF) of completed installation. Measurement shall be made along the pipe invert and shall include the length through elbows, tees and fittings.
2. *Payment:* Shall be paid for at the applicable contract unit price, payment for which shall be full compensation for the pipe, in place, complete including excavation, furnishing, perforating, hauling, assembling, jointing, special fittings, joint materials, pipe bedding, stainless steel cable, testing and all incidental work and material necessary for a complete installation to the required lines and grades shown on the drawings and where ordered by the Engineer.

Section 02635 - Bollards

A. Description. This work shall consist of furnishing and installing the bollards as shown on the drawings.

B. Materials

1. *Concrete:* Shall be in accordance with Section 00440 of the Oregon Standard Specifications.
2. *Pipe:* Pipe shall be 4 inch diameter hot-dip galvanized Schedule 40 steel pipe, in accordance with the drawings.
3. *Paint:* Paint and primer shall be suitable for outdoor application on steel pipe and shall be yellow.

C. Construction

1. The bollard shall be constructed in a vertical position, to the dimensions as shown on the drawings.
2. The steel pipe shall have all rough edges, areas and burrs ground smooth prior to painting.
3. Steel pipe shall be filled with concrete. The top of the bollard shall be graded to drain.
4. Paint and primer shall be applied after the concrete has set. Paint and primer shall be applied in accordance with the manufacturer's recommendations.

D. Measurement and Payment

No separate or additional payment will be made for Bollards, but shall be considered incidental to the work and shall be included in the applicable unit or lump sum bid items.

Section 02636 – Water Truck Filling Station

A. Description. The work under this section consists of the performance of all operations pertaining to furnishing and installing water truck filling station, in accordance with the drawings, these specifications, Avion Water Company's standards, City of Bend's Standards, Plumbing Code, and as required by the Engineer.

B. Materials

1. *Concrete:* Shall be in accordance with Section 00440 of the Oregon Standard Specifications.
2. *Pipe:* Pipe shall be ductile iron (DI) Thickness Class 52 from saddle on existing water main through the end unless specified otherwise on drawings.

3. *Vaults:* Vaults shall be Oldcastle 675-LA Precast Concrete Vault or equal.
4. *Flow Meter:* Flow Meter is to be Hersey/Mueller HB Mag Meter Hot Rod Ready w/Hot Rod Transmission Unit and external battery or approved equal.
5. *Double Check Valve Assembly:* DCVA's shall be Watts LF709 or equal.
6. *Valves:* Valves shall be Mueller 3" gate valve or equal.
7. *Valve Box:* Valve Boxes shall be cast iron valve box, East Jordan 910 18" top with an "AVION WATER" 3639 valve cover box cover. The riser pipe shall be a 6" 3034 PVC pipe.
8. *Mechanical Joint Restraint:* Mechanical joints shall have restrained glands of Megalug or equal. Restraint joints with transition gaskets must be used. Mechanical joint gaskets shall be pipe type specific gaskets. No universal gaskets will be accepted.
9. *Drain Rock:* Drain Rock to be 3" washed drain rock.
10. *Fittings:* All direct bury fittings shall be mechanical joint fittings. Fittings in a vault shall be flange.

C. Construction

1. Coordinate with Avion Water Company for the saddle connection to the existing fire hydrant supply pipe. If blasting will be utilized in excavation, Avion Water requires prior notification, no less than 24hrs, anytime blasting will be within 50ft from any live or abandoned Avion Water mainlines or facilities.

2. *Below-Ground Installation:*

Trench excavation shall be as shown on the design drawings and shall be open cut from the ground surface. Contractor most probably will encounter rock. Contractor shall complete excavation to depths specified in the drawings, regardless of conditions encountered. Water lines shall be a minimum of 12" from any rock, powerline, pipe, or other obstruction.

Unless otherwise specified, all piping shall be installed in below grade trenches with a minimum of 3-foot of cover measured from the top-of-pipe. Where required to provide a smooth grade a minimum of 6-inches pipe bedding shall be utilized. Bedding material shall be ¾" minus crushed rock or as approved by the engineer.

The Contractor shall be responsible for maintaining alignment and depth of the pipeline.

The proper locating tape and 14 gauge, or larger, wire shall be installed as directed. Proper wire nuts, rated for direct bury, with silicone, shall be used (e.g., DryConn DBR/Y-600, or equivalent). Locate wires in Valve tubes shall run outside the 3034 Riser Sleeve and inside the 910 Cast Iron Valve tube.

All pipe, fittings, weld joints must be reviewed by the Engineer and Avion Water Company prior to backfilling. The Contractor shall provide timely notice (at least 2 working days in advance of backfilling) to allow time for the Engineer to arrange for necessary inspections. Backfilling will not be allowed prior to the Engineer's review. This review does not relieve the Contractor of the responsibility for protection of the pipe against damage during backfilling.

Compact all embankment and bedding material to 95 percent of Modified Proctor maximum density as defined by ASTM D 1557.

3. *Inspection:*

The construction and installation from the saddle of the existing fire hydrant supply pipe through the flow meter and including the double check valve assembly will need to be inspected, approved and disinfected by Avion Water Company before water may be introduced into the system.

D. Measurement and Payment. Measurement and payment for the Water Truck Fill Station shall be in accordance with Section 01150 and the following:

1. *Measurement:* Shall be measured by the lump sum (LS) complete and in place.
2. *Payment:* Shall be paid for at the applicable contract unit price, payment for which shall be full compensation for the Water Truck Fill Station, in place, complete including excavation, furnishing, hauling, assembling, pipe, valves, jointing, special fittings, joint materials, pipe bedding, testing and all incidental work and material necessary for a complete installation to the required lines and grades shown on the drawings and where ordered by the Engineer.

Section 02638 – Chain Link Fence and Gates

A. Description. The work under this section consists of the performance of all operations pertaining to furnishing and installing Chain Link Fence and Gates, in accordance with the drawings, these specifications, and as required by the Engineer. All work shall be performed in accordance with Section 01050 of the Oregon Standard Specifications.

Chain Link Fence and Gates shall be Type CL-6 and shall be constructed in accordance with Oregon Standard Drawing No. RD815.

B. Materials

1. *Concrete:* Shall be in accordance with Section 00440 of the Oregon Standard Specifications.
2. *Chain Link Fabric:* Shall be in accordance with Section 03010.30 of the Oregon Standard Specifications.
3. *Double Swing Gates:* Double swing gates shall be 12-feet in width and shall be in accordance with Section 03010.60 of the Oregon Standard Specifications.
4. *Fence Grounding:* Shall be in accordance with Section 03010.50(e) and (f) of the Oregon Standard Specifications.
5. *Fence Posts, Braces and Appurtenances:* Shall be in accordance with Section 02110.30 and 03010.50 of the Oregon Standard Specifications.

C. Construction

Chain Link Fence and Gates shall be constructed in accordance with Section 01050 of the Oregon Standard Specifications.

D. Measurement and Payment

- 1) **Chain Link Fence:** Measurement and payment for Type CL-6 Chain Link Fence shall be in accordance with Section 01150 of these Specifications and the following:
 - a. *Measurement:* Shall be measured by the linear foot (LF) of completed installation. Measurement shall be made from center to center of posts, measured along the line and grade of each separate continuous run of fence as constructed, exclusive of gates.
 - b. *Payment:* Shall be paid for at the applicable contract unit price, payment for which shall be full compensation for the Chain Link Fence, in place, complete including clearing, grubbing and grading prior to the start of work; furnishing and installing fence posts, chain link fabric, braces, appurtenances and all incidental work and material necessary for a complete installation to the required lines and grades shown on the drawings and where ordered by the Engineer.

- 2) **Double Swing Gate:** Measurement and payment for 12-foot Double Swing Gate shall be in accordance with Section 01150 of these Specifications and the following:
1. *Measurement:* Shall be measured per Each that is complete and in place.
 2. *Payment:* Shall be paid for at the applicable contract unit price, payment for which shall be full compensation for the Double Swing Gate, in place, complete including clearing, grubbing and grading prior to the start of work; furnishing and installing fence posts, chain link fabric, braces, appurtenances and all incidental work and material necessary for a complete installation to the required lines and grades shown on the drawings and where ordered by the Engineer.

PART V
BID PROPOSAL FORMS

Bid Proposal

Bid Schedule

Bid Bond

First-Tier Subcontractor Disclosure Form

BID PROPOSAL

To: Deschutes County Department of Solid Waste
61050 SE 27th Street
Bend, Oregon 97702

Project Name: **Knott Landfill
Cell 9 Construction Project**

The undersigned, hereinafter called the Bidder, declares that the only persons or parties interested in this Proposal are those named herein; that this Proposal is, in all respects, fair and without fraud; and it is made without collusion with any official of Deschutes County, Oregon, hereinafter called County; and that the Proposal is made without any connection or collusion with any person making another proposal on this Contract.

The Bidder further declares that he has carefully examined the Contract documents and conditions of work involved, that he has satisfied himself as to the quantities involved, including materials and equipment, and conditions of work involved; and that this proposal is made according to the provisions and under the terms of the Contract documents, which documents are hereby made a part of this Proposal.

The Bidder agrees that all of the applicable provisions of Oregon law relating to public contracts (ORS Chapter 279) are, by this reference, incorporated in and made a part of this Proposal. Bidder hereby states that bidder will comply with ORS 279C.840.

Bidder (is) (is not) a resident bidder of the State of Oregon. If Bidder is a resident of another state, specify state of residency:

_____.

The Bidder further agrees that if this Proposal is accepted, he will, within ten (10) calendar days after notification of acceptance, execute the contract with the County in the form of contract annexed hereto; and will, at the time of execution of the contract, deliver to the County the Contract and Payment Bond (See Section 13 - Information for Bidders) required herein; and will, to the extent of this Proposal, furnish all materials necessary to complete the work in the manner, in the time, and according to the methods as specified in the contract documents and required by the Director of Solid Waste.

Bidder certifies that it has a drug testing program in place for its employees, or warrants that a drug testing program will be in place prior to execution of this contract, that the drug testing program is in writing, that new employees must pass a drug screening, that existing employees may be tested for reasonable cause or when an employee is injured or involved in an accident resulting in property damage. Bidder agrees that each subcontractor providing labor under this Contract shall maintain a qualifying drug testing program for the duration of the Contract.

The Bidder agrees to commence work upon the issuance of a "Notice to Proceed" by the County and fully complete the project according to the time schedule specially set forth in the contract documents. Bidder further agrees to pay liquidated damages for failure to complete within the specified time.

It is agreed that if the Bidder is awarded the contract for the work herein proposed and shall fail or refuse to execute the contract and furnish the contract and furnish the specified Performance and Payment Bond within ten (10) calendar days after receipt of notification of acceptance of his proposal, then, in that event, the bid security deposited herewith according to the conditions of the Invitation to Bid and Information for Bidders shall be retained by the County as liquidated damages; and it is agreed that the said sum is a fair measure of the amount of damage the County will sustain in case the Bidder shall fail or refuse to enter into the contract for the said work and to furnish the Performance and Payment Bond (See Section 13 Information for Bidders) as specified in the contract documents. Bid security in the form of a certified check shall be subject to the same requirements as a bond.

If the Bidder is awarded a contract on this Proposal, the Surety who will provide the performance bond will be

_____, whose address is

STREET

CITY

STATE

ZIP

Bid Schedule

Knott Landfill - Cell 9 Construction Project

Bid Item #	Specification Section	Item	Approximate Quantity	Unit	Unit Price	Total
1	02100	Mobilization	Lump Sum	LS	\$ Lump Sum	\$ _____
2	02110	Interface Friction Angle Testing	Lump Sum	LS	\$ Lump Sum	\$ _____
3	02150	Clearing and Grubbing	Lump Sum	LS	\$ Lump Sum	\$ _____
4	02200	Excavation	500,000	CY	\$ _____	\$ _____
5	02200	Embankment	10,000	CY	\$ _____	\$ _____
6	02300	Cushioning Layer	10,000	CY	\$ _____	\$ _____
7	02301	Drainage Layer	22,000	CY	\$ _____	\$ _____
8	02302	Base Course	250	CY	\$ _____	\$ _____
9	02303	2 inch Minus Aggregate	20,000	CY	\$ _____	\$ _____
10	02306	Hot Mixed Asphalt Concrete (HMAC)	125	CY	\$ _____	\$ _____
11	02311	Geosynthetic Clay Liner	560,000	SF	\$ _____	\$ _____
12	02312	Geomembrane	570,000	SF	\$ _____	\$ _____
13	02313	Cushioning Geotextile	15,000	SF	\$ _____	\$ _____
14	02313	Separating Geotextile	180,000	SF	\$ _____	\$ _____
15	02314	Geonet Composite	560,000	SF	\$ _____	\$ _____
16	02410	Landfill Gas Collection System	Lump Sum	LS	\$ Lump Sum	\$ _____
17	02624	8-inch Perforated HDPE Pipe	660	LF	\$ _____	\$ _____
18	02636	Water Truck Fill Station	Lump Sum	LS	\$ Lump Sum	\$ _____
19	02638	Type CL-6 Chain Link Fence	3,970	LF	\$ _____	\$ _____
20	02638	12-foot Double Swing Gate	5	Each	\$ _____	\$ _____
Total Bid Price						\$ _____
Total Bid Price (in Words) _____						
Submitted By: _____					Date: _____	

NOTES:

1. Bidder must bid on all items listed in the Bid Schedule.
2. All bids must be accompanied by a bid security in the amount of ten percent (10%) of the Total Bid Price. The bid award will be based upon the lowest bid submitted for the combined Total Bid Price.
3. The successful Bidder must post both a performance and payment bond each in the amount of one hundred percent (100%) of the awarded contract amount to guarantee that the successful bidder will fulfill all of his obligations under this Contract.

ACKNOWLEDGEMENT OF ADDENDUMS

The undersigned acknowledges receipt of and has incorporated the addenda listed below in the Total Bid Price submitted herein:

Addenda #	Signature	Date
_____	_____	_____
_____	_____	_____
_____	_____	_____
_____	_____	_____
_____	_____	_____
_____	_____	_____

It is understood that the right is reserved by Deschutes County to reject any or all proposals or bids. In the event that the Contract is not awarded within thirty (30) days after the receipt of bids, the Bidder will be released from his bid unless an extension of time is mutually agreed upon.

The undersigned certifies the bid prices contained in this proposal or bid have been carefully checked and are submitted as correct and final.

SIGNED AND SEALED THIS _____ day of _____, 2023

(Seal)

Firm Name

Location

By:

For:

Title:

Title:

The name of the Bidder submitting this Proposal is:

CCB#

Telephone Number

FAX Number

E-Mail Address

The address to which all communication regarding this proposal and the Contract shall be sent is:

Street or PO Box

City, State Zip

The names of the principal officers of the corporation submitting this Proposal, or of the partnership, or of all persons interested in this Proposal as principals, are as follows:

(IF SOLE PROPRIETOR OR PARTNERSHIP)

IN WITNESS THERETO, the undersigned has set his/her hand this _____ day of _____, 2023.

Signature of Bidder

Title

(IF CORPORATION)

IN WITNESS THEREOF, the undersigned corporation has caused this instrument to be executed and its seal affixed by its duly authorized officers this _____ day of _____, 2023.

Name of Corporation

By: _____
(Attach Power of Attorney or Corporate Resolution)

Title: _____

Attest: _____
Signature and Title

BID BOND

BOND NO. _____

KNOW ALL MEN BY THESE PRESENTS, that _____
_____, hereinafter called the Principal, and _____,
a corporation duly organized under the laws of the State of _____, having its principal place of business at
_____ in the state of _____, and authorized to do business in the State of
Oregon, as Surety, are held and firmly bound unto the _____
hereinafter called the Obligee, in the penal sum of _____ DOLLARS
(\$ _____), for the payment of which, well and truly to be made, we bind ourselves, our heirs, executors,
administrators, successors and assigns, jointly and severally, firmly by these presents.

The condition of this Bond is that, whereas the Principal herein is herewith submitting his or its bid for KNOTT LANDFILL
CELL 9 CONSTRUCTION PROJECT, said bid proposal, is by reference thereto made a part hereof.

NOW THEREFORE, if the said bid proposal submitted by the said principal be accepted, and the Contract be awarded to said
Principal, and if the said Principal shall execute the proposed Contract and shall furnish the Performance and Payment Bond as
required by the bidding and Contract documents with the time fixed by said documents, then this obligation shall be void,
otherwise to remain in full force and effect. Signed and sealed this ____ day of _____, 2023.

SURETY

CONTRACTOR

Surety's Name

Bidder's Name

By: _____

By: _____

Title: _____

Title: _____

FIRST-TIER SUBCONTRACTOR DISCLOSURE FORM

PROJECT NAME: **KNOTT LANDFILL CELL 9 CONSTRUCTION PROJECT**

BID CLOSING: Date: _____

Time: **2:00 pm**

NAME OF BIDDING CONTRACTOR: _____

List below the name of each subcontractor that will be furnishing labor or materials and that is required to be disclosed, the category of work that the subcontractor will be performing and the dollar value of the subcontract. Enter "NONE" if there are no subcontractors that need to be disclosed. (ATTACH ADDITIONAL SHEETS IF NEEDED.)

NAME	DOLLAR VALUE	CATEGORY OF WORK
1) _____	\$ _____	_____
2) _____	\$ _____	_____
3) _____	\$ _____	_____
4) _____	\$ _____	_____
5) _____	\$ _____	_____
6) _____	\$ _____	_____
7) _____	\$ _____	_____

Note: Within two working hours of the time bids are due to be submitted, all bidders shall submit this First Tier Subcontractor Disclosure Form to Mr. Tim Brownell County Department of Solid Waste either by fax at (541) 317-3959 or by delivery of this form to the Solid Waste Department Office at 61050 SE 27th Street, Bend, Oregon.

Failure to submit this form by the disclosure deadline will result in a nonresponsive bid. A nonresponsive bid will not be considered for award.

Form Submitted by (Bidder Name): _____

Contact Name: _____ Phone No.: _____

PART VI
AGREEMENT FORMS

Contract
Performance Bond
Payment Bond
Certificate of Insurance

CONTRACT

THIS CONTRACT, made and entered into, in duplicate, by and between DESCHUTES COUNTY, a political subdivision of the State of Oregon, hereinafter called "County" and _____, hereinafter called "Contractor", for the project entitled:

Knott Landfill Cell 9 Construction Project

WITNESSETH:

THAT the said Contractor, in consideration of the sums to be paid by the County in the manner and at the times herein provided, and in consideration of the other covenants and agreements herein contained, hereby agrees to perform and complete the work herein described and provided for, and to furnish all necessary things in accordance with the applicable contract documents, bound herewith, and in accordance with such alterations or modifications of the same as may be made by the County, and according to and within the meaning and purpose of this contract. This Agreement shall be binding upon the heirs, executors, administrators, successors and assigns of the Contractor.

THAT the Contract Documents, consisting of Invitation to Bid, Information for Bidders, General Conditions, Special Provisions, Bid Proposal, Bid Schedule, Bid Bond, Award, Subcontractor Disclosure, Contract, Performance Bond, Payment Bond, Certificate of Insurance, Prevailing Wage Rates, Supplemental Standard Specifications, and Plans and Standard Drawings bound herewith are hereby specifically referred to and by this reference made a part hereof, and shall by such reference have the same force and effect as though all of the same were fully written or inserted herein.

THAT the Contractor shall faithfully complete and perform all of the obligations of this Contract, and in particular, shall promptly, as due, make payment of all just debts, dues, demands and obligations incurred in the performance of said Contract; and shall not permit any lien or claim to be filed or prosecuted against the County, its agents or employees. It is expressly understood that this Contract in all things shall be governed by the laws of the State of Oregon, and the Ordinances of the County.

THAT in consideration of the faithful performance of all of the obligations, general and special, herein set out, and in consideration of the faithful performance of the work as set forth in the Contract Documents in accordance with the directions of the Director of Solid Waste and to his satisfaction, the County agrees to pay to the said Contractor the amount earned, as determined from the quantities of work performed, and taking into consideration any amounts that may be deductible and under the terms of the Agreement, and to make such payments in the manner and at the times provided in the applicable provisions, and schedule of contract prices.

IN WITNESS WHEREOF, DESCHUTES COUNTY has caused this agreement to be signed in its name, by its Board of County Commissioners, duly attested by its Recording Secretary; and the said Contractor has caused this Agreement to be signed and sealed the same as of the _____ day of _____, 2023.

DATED this _____ day of _____, 2023.

BOARD OF COUNTY COMMISSIONERS
OF DESCHUTES COUNTY, OREGON

Anthony DeBone, County Commissioner

Patti Adair, County Commissioner

Phil Chang, County Commissioner

Attest: _____
Recording Secretary

CONTRACTOR

By: _____
(Attach Power of Attorney or Corporate Resolution)

Title: _____

Attest: _____
Signature and Title

APPROVED

Tim Brownell, Director of Solid Waste

APPROVED AS TO FORM:

Legal Counsel

Performance Bond

Bond No. _____

KNOW ALL MEN BY THESE PRESENTS that

(Name of Contractor)

(Address of Contractor)

a _____, hereinafter called
(Corporation/Partnership/Individual)

Principal, and _____
(Name of Surety)

hereinafter called Surety, are held and firmly bound unto Deschutes County, hereinafter called OWNER, in the penal sum of _____ dollars (\$ _____) in lawful money of the United States, for the payment of which sum well and truly to be made, we bind ourselves, successors, and assigns, jointly and severally, firmly by these presents.

THE CONDITION OF THIS OBLIGATION is such that whereas the Principal entered into a certain Contract with the Owner, dated the _____ day of _____, 2023, a copy of which is hereto attached and made a part hereof for the construction of the **Knott Landfill Cell 9 Construction Project**.

NOW THEREFORE, if the Principal shall well, truly and faithfully perform its duties, all the undertakings, covenants, terms, and conditions, and contracts of said Contract during the original term thereof, and any extensions thereof which may be granted by the OWNER, with or without notice to the Surety and during the **ONE YEAR GUARANTY PERIOD**, and if he shall satisfy all claims and demands incurred under such Contract, and shall fully indemnify and save harmless the OWNER from all costs and damages which it may suffer by reason of failure to do so, and shall reimburse and repay the OWNER all outlay and expense which the OWNER may incur in making good any default, then this obligation shall be void; otherwise to remain in full force and effect.

PROVIDED FURTHER, that the said surety, for value received hereby stipulates and agrees that no change, extension of time, alteration or addition to the terms of the Contract or to WORK to be performed thereunder or the SPECIFICATIONS accompanying the same shall in any wise affect its obligation on this BOND, and it does hereby waive notice of any such change, extension of time, alteration or addition to the terms of the Contract or to the WORK or the SPECIFICATIONS.

PROVIDED FURTHER, that no final settlement between the OWNER and the Principal shall abridge the right of any beneficiary hereunder, whose claim may be unsatisfied.

IN WITNESS WHEREOF, this instrument is executed in _____ counterparts, each one of which shall be deemed an original,
this _____ day of _____ 2023.

ATTEST:

(Principal) Secretary
(Seal)

Principal
BY: _____

Witness as to Principal
Address

Address

ATTEST:
(Seal)

Witness as to Surety
Address

Agent of Record Telephone Number

Surety
BY: _____
Attorney in Fact

Address

NOTE: Date of BOND must not be prior to date of Contract.
If CONTRACTOR is partnership, all partners should execute BOND.

Payment Bond

Bond No. _____

KNOW ALL MEN BY THESE PRESENTS that

(Name of Contractor)

(Address of Contractor)

a _____, hereinafter called
(Corporation/Partnership/Individual)

Principal, and _____
(Name of Surety)

hereinafter called Surety, are held and firmly bound unto Deschutes County, hereinafter called OWNER, in the penal sum of _____ dollars (\$ _____) in lawful money of the United States, for the payment of which sum well and truly to be made, we bind ourselves, successors, and assigns, jointly and severally, firmly by these presents.

THE CONDITION OF THIS OBLIGATION is such that whereas the Principal entered into a certain Contract with the Owner, dated the ____ day of _____, 2023, a copy of which is hereto attached and made a part hereof for the construction of the **Knott Landfill Cell 9 Construction Project**.

NOW, THEREFORE, if the Principal shall promptly make payment as due to all persons, firms, SUBCONTRACTORS, and corporations furnishing materials for or performing labor in the prosecution of the WORK provided for in said contract, and any authorized modification thereof, including all amounts due for materials, lubricants, oil, gasoline, coal and coke, repairs on machinery, equipment and tools consumed or used in connection with the construction of such WORK, and all insurance premiums on said WORK, and for all labor performed in such WORK whether by SUBCONTRACTOR or otherwise, then this obligation shall be void; otherwise to remain in full force and effect.

PROVIDED FURTHER, that the said surety for value received hereby stipulates and agrees that no change, extension of time, alteration or addition to the terms of the Contract or to the WORK to be performed thereunder or the SPECIFICATIONS accompanying the same shall in any wise affect its obligation on this BOND, and it does hereby waive notice of any such change, extension of time, alteration or addition to the terms of the Contract or to the WORK or the SPECIFICATIONS.

PROVIDED FURTHER, that no final settlement between the OWNER and the CONTRACTOR shall abridge the right of any beneficiary hereunder, whose claim may be unsatisfied.

IN WITNESS WHEREOF, this instrument is executed in _____ counterparts, each one of which shall be deemed an original, this _____ day of _____ 2023.

ATTEST:

(Principal) Secretary
(Seal)

Principal
BY: _____

Witness as to Principal
Address

Address

ATTEST:
(Seal)

Witness as to Surety
Address

Agent of Record Telephone Number

Surety
BY: _____
Attorney in Fact

Address

NOTE: Date of BOND must not be prior to date of Contract.
If CONTRACTOR is partnership, all partners should execute BOND.

DESCHUTES COUNTY
INSURANCE REQUIREMENTS

Contractor shall at all times maintain in force at Contractor's expense, each insurance noted below. Insurance coverage must apply on a primary or non-contributory basis. All insurance policies, except Professional Liability, shall be written on an occurrence basis and be in effect for the term of this contract. Policies written on a "claims made" basis must be approved and authorized by Deschutes County.

Project: Knott Landfill - Cell 9 Construction Project

Workers Compensation Insurance in compliance with ORS 656.017, requiring Contractor and all subcontractors to provide workers' compensation coverage for all subject workers, or provide certification of exempt status. Worker's Compensation Insurance to cover claims made under Worker's Compensation, disability benefit or any other employee benefit laws, including statutory limits in any state of operation with Coverage B Employer's Liability coverage all at the statutory limits. In the absence of statutory limits the limits of said Employer's Liability coverage shall be not less than \$1,000,000 each accident, disease and each employee. This insurance must be endorsed with a waiver of subrogation endorsement, waiving the insured's right of subrogation against County.

Professional Liability insurance with an occurrence combined single limit of not less than:

Per Occurrence limit	Annual Aggregate limit
----------------------	------------------------

- | | |
|--------------------------------------|--------------------------------------|
| <input type="checkbox"/> \$1,000,000 | <input type="checkbox"/> \$2,000,000 |
| <input type="checkbox"/> \$2,000,000 | <input type="checkbox"/> \$3,000,000 |
| <input type="checkbox"/> \$3,000,000 | <input type="checkbox"/> \$5,000,000 |

Professional Liability insurance covers damages caused by error, omission, or negligent acts related to professional services provided under this Contract. The policy must provide extended reporting period coverage, sometimes referred to as "tail coverage" for claims made within two years after the contract work is completed or the facts underlying County's claim could reasonably have been discovered, whichever is later.

Required by County Not required by County (one box must be checked)

Commercial General Liability insurance with a combined single limit of not less than:

<u>Per Single Claimant and Incident</u>	<u>All Claimants Arising from Single Incident</u>
---	---

- | | |
|---|---|
| <input checked="" type="checkbox"/> \$1,000,000 | <input checked="" type="checkbox"/> \$2,000,000 |
| <input type="checkbox"/> \$2,000,000 | <input type="checkbox"/> \$3,000,000 |
| <input type="checkbox"/> \$3,000,000 | <input type="checkbox"/> \$5,000,000 |

Commercial General Liability insurance includes coverage for personal injury, bodily injury, advertising injury, property damage, premises, operations, products, completed operations and contractual liability. The insurance coverages provided for herein must be endorsed as primary and non-contributory to any insurance or self insurance of County, its officers, employees or agents. Each such policy obtained by Contractor shall provide that the insurer shall defend any suit against the named insured and the additional insureds, their officers, agents, or employees, even if such suit is frivolous or fraudulent.

The policy shall be endorsed to name ***Deschutes County, its officers, agents, employees and volunteers as an additional insured***. The additional insured endorsement shall not include declarations that reduce any per occurrence or aggregate insurance limit. The Contractor shall provide additional coverage based on any outstanding claim(s) made against policy limits to ensure that minimum insurance limits required by the County are maintained. Construction contracts may include aggregate limits that apply on a "per location" or "per project" basis. The additional insurance protection shall extend equal protection to County as to Contractor or subcontractors and shall not be limited to vicarious liability only or any similar limitation. To the extent any aspect of this Paragraph shall be deemed unenforceable, then the additional insurance protection to County shall be narrowed to the maximum amount of protection allowed by law.

Required by County Not required by County (One box must be checked)

Claims Made Policy Approved by County Not Approved by County

Automobile Liability insurance with a combined single limit of not less than:

Per Occurrence

\$500,000

\$1,000,000

\$2,000,000

Automobile Liability insurance includes coverage for bodily injury and property damage resulting from operation of a motor vehicle. Commercial Automobile Liability Insurance shall provide coverage for *any* motor vehicle (symbol 1 on some insurance certificates) driven by or on behalf of Contractor during the course of providing services under this contract. Commercial Automobile Liability is required for contractors that own business vehicles registered to the business. Examples include: plumbers, electricians or construction contractors. An Example of an acceptable personal automobile policy is a contractor who is a sole proprietor that does not own vehicles registered to the business.

Required by County Not required by County (one box must be checked)

Additional Requirements. Contractor shall pay all deductibles and self-insured retentions. A cross-liability clause or separation of insured's condition must be included in all commercial general liability policies required by this Contract. Contractor's coverage will be primary in the event of loss.

Certificate of Insurance Required. Contractor shall furnish a current Certificate of Insurance to the County with the signed Contract. Contractor shall notify the County in writing at least 30 days in advance of any cancellation, termination, material change, or reduction of limits of the insurance coverage. The Certificate shall also state the deductible or, if applicable, the self-insured retention level. Contractor shall be responsible for any deductible or self-insured retention. If requested, complete copies of insurance policies shall be provided to the County. Any violation by Contractor of this Certificate of Insurance provision shall, at the election of County, constitute a material breach of the Contract.

PART VII
GEOTECHNICAL SITE CONDITIONS

SIEMENS & ASSOCIATES

G. Friesen and Associates, Inc.
4088 Orchard Drive
Lake Oswego, Oregon 9035
Attention: Gerry Friesen, P.E.

August 29, 2023

Project Number 230026

Project: Knott Landfill: Cell 9 Design and Analysis
Deschutes County, Oregon

Subject: Geotechnical Site Conditions

Hello Gerry:

Siemens & Associates (SA) is pleased to deliver this report describing the soil and rock exploration throughout the area proposed for expansion into Cell 9 and beyond. The findings are presented in graphical format including geophysical profiles, a summary of conditions encountered and laboratory test results in an appendix. Figure 100 (Site Plan: Geotechnical Exploration) illustrates the location of the various exploration points. This report was originally submitted in September of 2021 and has been updated to reflect current conditions.

Scope

The exploration and interpretation are based on results from geophysical methods combined with basic geotechnical field reconnaissance, previous site experience and data from historic borings. The boundary of the exploration extends through the proposed Cell 9 footprint with explorations extrapolated as necessary to provide more global analysis where required.

Purpose

The purpose is to provide information useful for the design and permitting process and general information for construction planning. The interpretation is not prepared specifically for construction estimation. SA recognizes that this document may represent the most current and detailed information for construction planning and estimating yet recommend that construction cost estimation be developed by prospective bidders using independent interpretation as appropriate to supplement the information reported here.

Project Understanding

The project includes several tasks related to the geotechnical exploration including:

- Effective excavation and reuse of the soil and rock removed to shape the subgrade for Cell 9
- Production of select soil layers to build various liner components (subgrade, cushion layer,

Siemens & Associates
office: 541-385-6500

siemens@bendcable.com
19134 River Woods Drive

Bend, Oregon
fax: 503-296-2271

- pipe bedding and drainage layers)
- Perimeter road extension
- Aggregate production for various crushed rock products

Encountered Conditions

History

The geotechnical conditions interpreted from this exploration are consistent with neighboring geology associated with previously explored landfill cells. Currently, landfill operations are procuring soils for daily operations from sources stockpiled from previous excavation of similar geology. With minor exceptions, the topography as illustrated on the drawings is an accurate representation of the existing conditions. Prior earthwork operations removed the majority of the upper basalt layer. The remaining area of upper basalt is obvious in some areas and less so in others including the southwestern area of Cell 9. Previous excavation and rock processing have resulted in the scattered deposition of rocky spoils embedded within the otherwise sandy and finer grained native materials.

Topography and Surface Conditions



Surface conditions are essentially void of vegetation. However, a few areas have collected wind-blown debris (mostly paper, plastic and other lightweight trash) which must be removed as part of the clearing and grubbing operation. The exception is the northern slope of Area A where grubbing of surficial vegetation (grasses and weeds) must be removed.

The Cell 9 construction zone has been utilized as a borrow source and stockpile for landfill operations and the topography has been shaped to include an access road to Cell 8 which extends through the western area of the proposed Cell 9. Figure 100 includes shaded areas to illustrate zones that are believed to be dominated by municipal solid waste (MSW) associated with historic disposal in what is known as Area A1. Other activities including onsite rock processing have left behind surface accumulations of cobbles and boulders in various areas. The rock particles (greater than 6 inches) render the material inappropriate for export to soil stockpile. In the opinion of SA, the rocky materials are suitable for processing as aggregate through crushing operations.

Stratification

The native soil and rock encountered are typical of the Knott Landfill geology which is composed of a thin layer of topsoil underlain by an upper basalt formation further underlain by a thick sequence of unconsolidated soil layers which rest on a lower basalt formation of variable elevation and character. Stratification is defined using a numeric system consistent with previous exploration that SA has presented for soils at Knott Landfill to define geotechnical conditions. These conditions are summarized as follows:

Table 1: Stratification			
Stratum	Thickness (ft)	Visual Description	Anticipated Project Uses
3a	0 to 32	Upper Basalt: Gray – moderate to heavily fractured and jointed (vertically), some horizontal fractures, moderate to highly vesicular	Process for aggregate products: Drainage layer, base course, and loosely specified 2 inch minus aggregate useful for general landfill operations
2s	3 to 7	Sand: Brown: - small amount silt, trace fine gravel	Cushioning layer, structural backfill, general embankment, pipe bedding and stockpile
2g	5 to 10	Sand & Fine Gravel: Gray to Black – Clean sand with fine gravel, trace silt	Cushioning layer, structural backfill, general embankment, pipe bedding and stockpile
2c	7 to 16	Cemented Sand with Silty Seams: - Gray to Black – lightly cemented fine sand with alternating silty lenses: Tends to excavate with stiff, silty blocks, difficult to breakdown for some uses	Cushioning layer (if blocky structure is broken down), general embankment, and stockpile
2sm	2 to 15	Sand w/ Silt: Brown	Cushioning layer, structural backfill, general embankment, and stockpile
2m	2 to 8	Silt w/ clay: Brown – occurs above lower basalt, wet, moderately plastic	General embankment, stockpile, and low permeability gas migration layer
3b	0 to 20+	Lower Basalt: Gray – moderately vesicular, jointed and fractured, hard. This layer includes anomalies including voids and soil filled zones	Process for aggregate products: Drainage layer, base course, and loosely specified 2 inch minus aggregate useful for general landfill operations

To develop a description of the existing conditions, SA implemented electrical resistivity tomography (ER) as a primary geophysical exploration tool. The method was very effective in describing the soil thickness and position of the underlying lower basalt along with some indications of the nature of the soils themselves. The soils described in Table 1 were found to be layered through the excavation depth in a reasonably uniform manner. Figure 200 (Conceptualized Stratification) is presented in the appendix to provide a sense of the typical soil profile. The stratification defined by Figure 1 is conceptual and not related to any specific area of Cell 9.

Groundwater

No groundwater was encountered although the silty soils of Stratum 2m become very wet near the contact with the lower basalt (Stratum 3b) and due to low permeability, these soils will drain poorly such that surface water may temporarily pond as a free water surface given heavy rain or snow melt.

Excavation/Materials Usage Considerations

Difficulty

The soils encountered are anticipated to excavate readily using conventional equipment including powerful excavators, scrapers and blades rated D-8 and larger. Deschutes County scraper operators commonly experience some difficulty with Stratum 2c and typically loosen the strata with rippers prior to removal. Other soil layers offer only minor resistance to scraper removal.

Basalt excavation (Strata 3a and 3b) is expected to be difficult requiring drill and blast efforts for any cut greater than a few feet. Minor rock excavation is commonly accomplished using pneumatic chisel techniques. Upper basalt excavation is anticipated through limited zones along the north, east and southern perimeter of the work area. Lower basalt is expected throughout portions of the Cell 9 floor.

Strata between the upper and lower basalt generally excavate with ease except for Stratum 2c as discussed. As described through Table 1 (Stratification), there are significant differences in the layers to be encountered although each layer has common usage including export to stockpile. The cemented nature of Stratum 2c differentiates this layer from the others due to a tendency to excavate in a blocky manner with the generation of many chunks that can be difficult to break down for usage such as the cushion layer which requires grading to precise lines. For this reason, soils associated with Strata 2s and 2g are judged to be the most appropriate set-aside for use as cushion layer.

MSW (municipal solid waste) is anticipated to dominate excavation in the southwestern area of Cell 9. The extent of the MSW is illustrated by shaded areas on Figure 100 and as low inverted resistivity on the electrical tomograms. This is an area of complicated subsurface and the 3D model presented in the appendix effectively describes the conditions.

Special consideration for various geotechnical products is discussed as follows:

Rock and Aggregate Products

Upper and lower elevation basalt and miscellaneous loose rocky debris from previous activity is anticipated to be utilized to produce various rock products including drainage layer, and a loosely graded 2 inch minus crushed aggregate.

A total rock excavation volume is not presented although only a modest percentage of the cut is anticipated to be rock. A typical swell factor from in-place to loose shot rock stockpile or processed aggregate ranges from 30% to about 40%.



Soil Products

The soils of Strata 2s and 2g are best suited for grading and compaction for select purposes including cushion layer and pipe bedding. Therefore, there is advantage in separating and stockpiling these materials as they are encountered, reserving the soil for special use during construction of the liner and ancillary components. Included in the appendix is a log describing the general sequence of stratification (Figure 200, Conceptualized Stratification). This log represents an exposure that no longer exists; however, the general descriptions remain valid for Cell 9.

Liner System Subgrade Performance

The southern edge of the Cell 9 liner system is anticipated to be supported by subgrade composed of MSW. Other areas offer traditional subgrade support composed of either native soils or embankment composed of native soils or rock. These conditions have historically provided excellent subgrade and will not be discussed further.

To evaluate liner performance where constructed on MSW, SA has assessed the condition through interpretation of the geophysical findings including the ER to provide estimate of thickness and LM (S-wave velocity, shear modulus) to provide estimation of consolidation characteristics. These

characteristics have been combined with an estimate of load based on the current closure model. The analyses consider the existing MSW to be slowly loaded to an elevation of roughly 3740 feet suggesting a surcharge of about 30 feet.

Using the geophysical results to estimate existing MSW thickness and strength combined with an elastic analysis, as much as three inches of consolidation is expected to be induced by the surcharge. The transition from strong subgrade to MSW with thickness on the order of 50 feet occurs over a span of about 20 feet. As a result, the three-inch settlement will be differential across this 20-foot span.



Summary

The geotechnical exploration described in this report and supported by illustrations provided in the appendix provides a valuable resource that has been used to guide the design of geotechnical components and preparation of construction documents. The information is presented in a concise format complete with graphics illustrating the interpretation of the conditions encountered through long geophysical traverses.

Limitations

The information provided in this report represents an endeavor to meet the prevailing area standard of care practiced by geoprofessionals conducting geotechnical and geophysical exploration and interpretation for similar purpose in the Bend, Oregon area. SA offers no other warrantee express or implied.

SA appreciates the opportunity to provide this information and sincerely hope that it meets your requirements. As you and the design team have questions, please call.

Prepared by:

Siemens & Associates

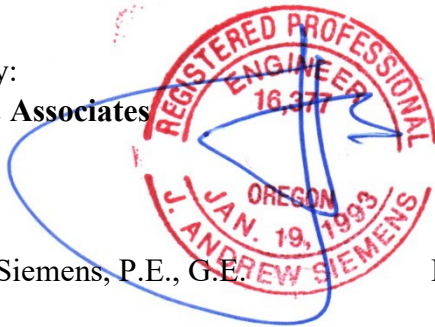

J. Andrew Siemens, P.E., G.E.

Renews: 6-30- '24

Addressee: 1 electronic

Enclosures: Field Data Appendix

Appendix:

Field Exploration Appendix to Geotechnical Site Conditions

The subsurface exploration began with a review of existing data followed by foot reconnaissance then geophysical reconnaissance using electrical resistivity imaging (ER), linear microtremor (LM) and the spatial auto-correlation (SPAC) method. The results developed from the procedures used provide a robust description of the subsurface conditions to a level of detail appropriate for developing an understanding of the type of soils, rock and other materials including MSW (municipal solid waste) to be expected along with distribution of these materials.

Geophysical lines are numbered in sequence with previous, similar work. Therefore, the numbers do not start at one. The field work, data processing and interpretation were conducted by J. Andrew Siemens PE, GE, during August and September of 2021. Procedures are described as follows:

Linear Microtremor (LM): How it works

The LM analysis develops the shear-wave velocity/depth profile using an engineering seismograph, low frequency receivers (geophones) and straight-line array. Ambient surface wave energy is recorded using relatively long sample window (30 seconds) recording the ambient wavefield which at this site was limited and was enhanced



with high frequency from a plate and hammer at each end of the array and by landfill operations that were underway during the time of the survey.

The microtremor records are transformed as a simple, two-dimensional slowness-frequency (p-f) plot where the ray parameter “p” is the horizontal component of slowness (inverse velocity) along the array and “f” is the corresponding frequency (inverse of period). The p-f analysis produces a record of the total spectral power in all records from the site, which plots within the chosen p-f axes. The trend within these axes where a coherent phase has significant power is “picked” (as illustrated by the blue points on the spectral plot). Then the slowness-frequency picks can be transformed to a typical period-velocity diagram for dispersion analysis as shown on the figures that accompany the shear-wave profile identified as the Supportive Illustrations. Picking the points to be entered into the dispersion curve is done manually along the lowest velocity envelope bounding the energy appearing in the p-f image.

It is important to recognize that the one dimensional interpretation (plot) of shear-wave velocity versus depth from an LM survey is representative of the “average” conditions in the area of the survey and may or may not correlate well with data gathered from more traditional methods such as cross-hole techniques that measure conditions at a select location. The LM analysis would, however, agree well with the average of many down-hole measurements if



such extensive work were done in the area of the LM survey and agreement would be achieved with a single down-hole test if subsurface conditions were reasonably uniform across the survey site.

LM data is utilized to verify assumptions associated with the Seismic Site Hazard Evaluation presented in a separate report. The information also bears directly upon the strength of the materials sampled and has been used to evaluate the strength and consolidation characteristics of the MSW expected to be encountered and utilized as support for an isolated segment of the new liner system.

Electrical Resistivity Tomography (ER): How it works

Two-dimensional (2D) electrical resistivity tomography is a geophysical method to evaluate the electrical characteristics of the subsurface by taking measurements along a survey line at the surface. These measurements are then inverted to provide a description of the electrical resistivity in two dimensions which is in turn related to the likely distribution of geologic or cultural features known to offer similar electrical properties. A measurement in an electrical survey involves injecting DC current into the ground through two current-carrying electrodes and measuring the resulting voltage difference at two potential electrodes. The apparent resistivity is calculated using the value of the injected current, the voltage measured, and a geometric factor related to the arrangement of the electrodes.

The investigation depth of electrical resistivity is related to the spacing between the electrodes that inject electrical current. Therefore, sampling at different depths can be done by changing the spacing between the electrodes. Measurements are repeated along a survey line with various combinations of electrodes and spacing to produce an apparent resistivity cross-section. In this case, SA used data sets from three arrays (Dipole-Dipole, Inverted Schlumberger, and Strong



Gradient) from lines with 6.25 m electrode spacing. Rugged topography (including cliffs) were surveyed and the steep zones caused some distortion in the results.

Since consecutively deeper readings are influenced by overlying strata, apparent resistivity data are inverted mathematically to generate the model. Many geological/environmental or cultural factors affect or control the resistivity of the subsurface. Geologic layers are interpreted from electrical contrast. In this survey, the character of the contrast varies and the bottom of the upper basalt appears to offer a similar inverted electrical resistivity as the underlying sand and gravel layer cinder. Therefore, upper to readily distinguish soil from rock. SA inverted the data using Advanced Geosciences Earth Imager software in both 2D and 3D.

Spatial Auto-correlation (SPAC): How it works

In support of various engineering endeavors, surface wave analysis is widely utilized for obtaining near surface shear wave velocity models to define geologic conditions in terms of shear wave velocity. The analyses provide information about the variation in shear-wave velocity with depth averaged across a relatively large area (compared to a boring) gaining insight regarding geologic conditions that can be difficult to detect through alternative methods. SPAC is a passive method using ambient vibrations and the Rayleigh waves that these ambient energy sources produce. Since the array occupies a small, 2D footprint, the SPAC method is well suited for this site to provide a second opinion regarding the position of geologic boundaries.



Ambient seismic noise or microtremor observations used in the SPAC method consist of a wide frequency range of surface waves from the frequency of about 3 Hz to several tens of Hz in this survey. The wavelengths (and hence depth sensitivity of such surface waves) allow determination of the site S-wave velocity model from depths of a few feet down to a maximum of several

thousand feet with large arrays and low frequency receivers. SPAC is a passive seismic method using only ambient noise as the energy source.

SA utilized a 2D seismic array composed of 24, 4.5 Hz receivers on 10 foot spacing representing a series of nested equilateral triangles (longest leg = 60 feet) to estimate the phase velocity dispersion curve and hence the 1D S-wave velocity depth profile very near the intake and diversion structure. Direct fitting of observed and model SPAC spectra generally provides a bandwidth of useable data like the more common, linear MASW array when linear results from a pair of mutually perpendicular arrays are averaged. Available case histories demonstrate the method with a range of array types including L-shaped multi-station arrays, triangular, and circular arrays. Array sizes from a few feet to thousands of feet in diameter have been successfully deployed in sites ranging from downtown urban settings to rural and remote desert sites.

A fundamental requirement of the method is the ability to average wave propagation over a range of azimuths; this can be achieved with either or both of the wave sources being widely distributed in azimuth, and the use of a 2D array sampling the wave field over a range of azimuths. SA has had best success using dense to moderately dense nested triangular arrays. 2D passive seismic arrays have become the method of choice when characterizing average S-wave velocity to a depth of 100 feet (V_{s100}) and deeper, with active (or passive) linear seismic methods such as multichannel analysis of surface waves (MASW) being a complementary method for use if and when conditions so require. The use of computer inversion methodology allows estimation of not only the average S-wave velocity profile but also parameter uncertainties in terms of layer thickness and velocity.

The SPAC analysis develops the shear-wave velocity/depth profile using engineering seismographs, low frequency receivers (geophones), and 2D array aperture. Surface wave energies (Rayleigh Waves) are recorded using a relatively long sample window (120 to 240 seconds) recording the ambient wavefield. For this project, a broad range of low to high frequency signal was consistently recorded from energy and vibrations developed from landfill operations and other sources that were not readily defined. Data were processed using Surface Plus 9.3 software produced by Geogiga Technology Corporation of Calgary, Canada.

In processing, the microtremor records are transformed as a simple, two-dimensional frequency (f) plot. The f analysis produces a record of the total spectral power in all records from the site, which plots within the chosen f axes. The trend within these axes, where a coherent phase has significant power, is “picked”. Then the frequency picks are transformed for dispersion analysis. Picking the points to be entered into the dispersion curve is done manually along the velocity appearing in the f image. The solution is not unique, and a trial-and-error approach is utilized to build a theoretical model that represents a reasonable “fit” with the observations (data).

Survey Line Locations, Data Acquisition and Gear

The location of each survey is illustrated on Figure 100. The locations shown were marked in the field with four foot wood lath and flagging. Distances were measured using 300-foot fiberglass tape measures with reference to various survey control points set by the project surveyor (John Thompson, P.L.S.). In the opinion of SA, horizontal positioning is likely within a few feet as shown on Figure 100 and vertical positions are estimated to be within about two feet as illustrated on the tomograms.



Seismic data were collected using a 24 channel DAQLink 4 digital seismograph manufactured by Seismic Source, Ponca City, Oklahoma and data were processed by us using GeoGiga DW Tomo 9.3 software, Calgary, Canada.



Electrical data were procured with a SuperSting R-8 resistivity instrument manufactured by Advanced Geosciences, Inc., (AGI) Austin Texas utilizing AGI's Earth Imager inversion software.

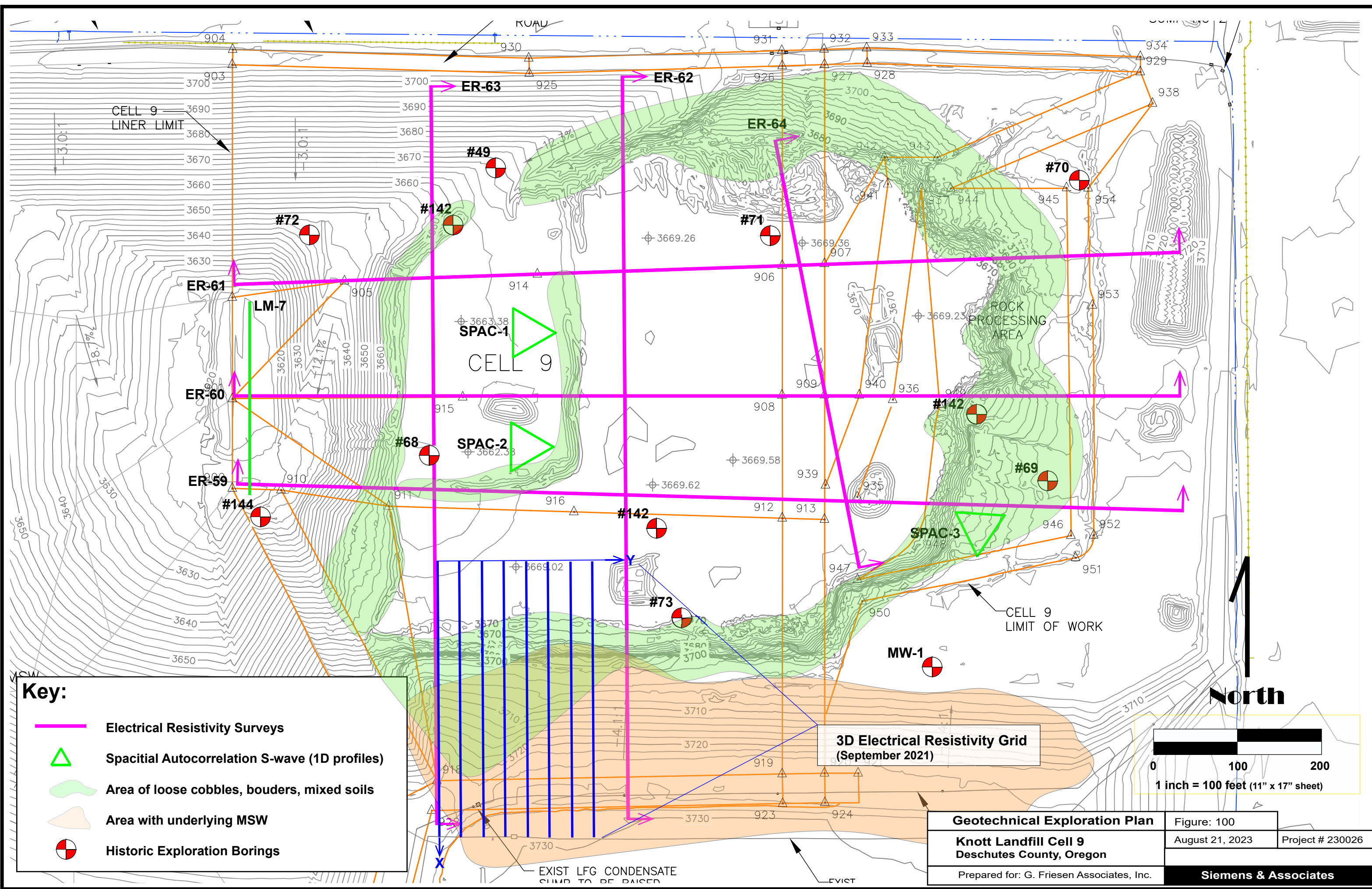

Key:

- Electrical Resistivity Surveys
- △ Spacial Autocorrelation S-wave (1D profiles)
- Area of loose cobbles, bouders, mixed soils
- Area with underlying MSW
-  Historic Exploration Borings

**3D Electrical Resistivity Grid
(September 2021)**

Geotechnical Exploration Plan		Figure: 100
Knott Landfill Cell 9 Deschutes County, Oregon		August 21, 2023
Prepared for: G. Friesen Associates, Inc.		Project # 230026
Siemens & Associates		

Figure 200

Conceptualized Stratification

Knott Landfill: Cell 9 Design and Analysis
Deschutes County, Oregon

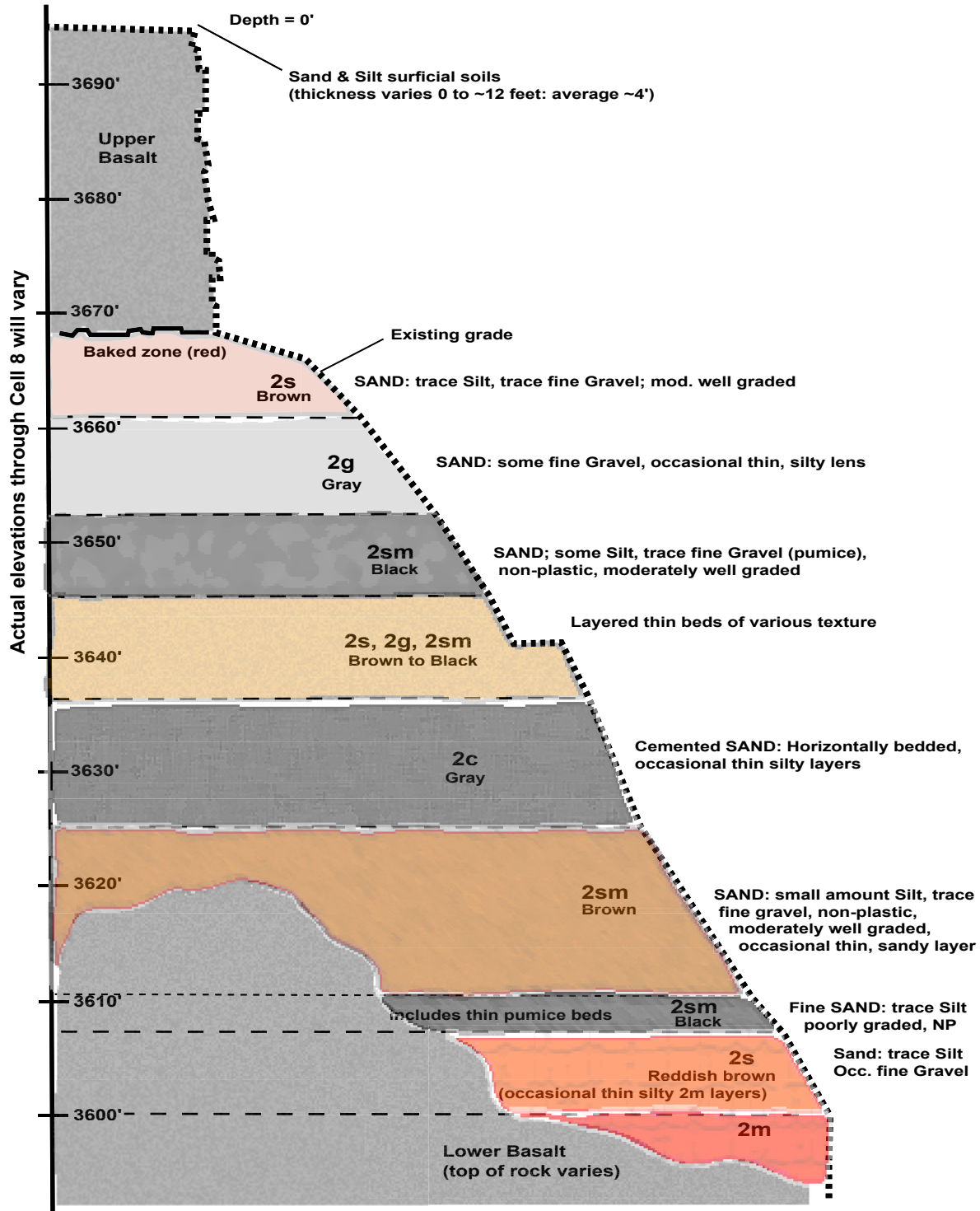

Electrical Resistivity Tomography: ER-59

(56 electrodes on 6.25 m spacing: combined Dipole-Dipole, inverted Schlumberger and Strong Gradient arrays)

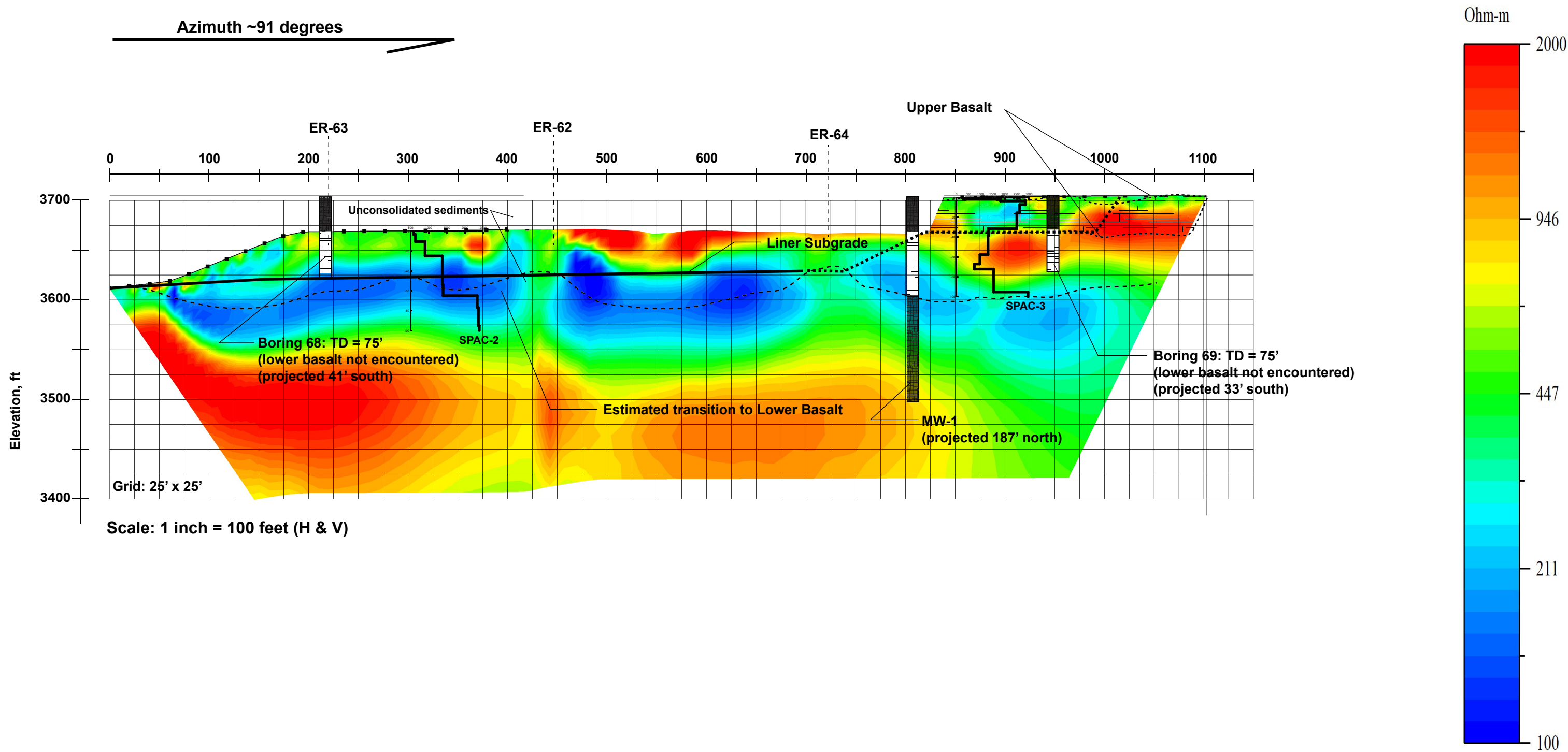

Note: boring data are from historic surveys at Knott Landfill and presented as additional information bearing on this project

Electrical Resistivity Tomography: ER-59	Figure: ER-59	
Knott Landfill Cell 9 Deschutes County, Oregon	September 7, 2021	Project # 210021
Prepared for: G. Friesen Associates, Inc.	updated August 2023	
Siemens & Associates		

Electrical Resistivity Tomography: ER-60

(56 electrodes on 6.25 m spacing: combined Dipole-Dipole, inverted Schlumberger and Strong Gradient arrays)

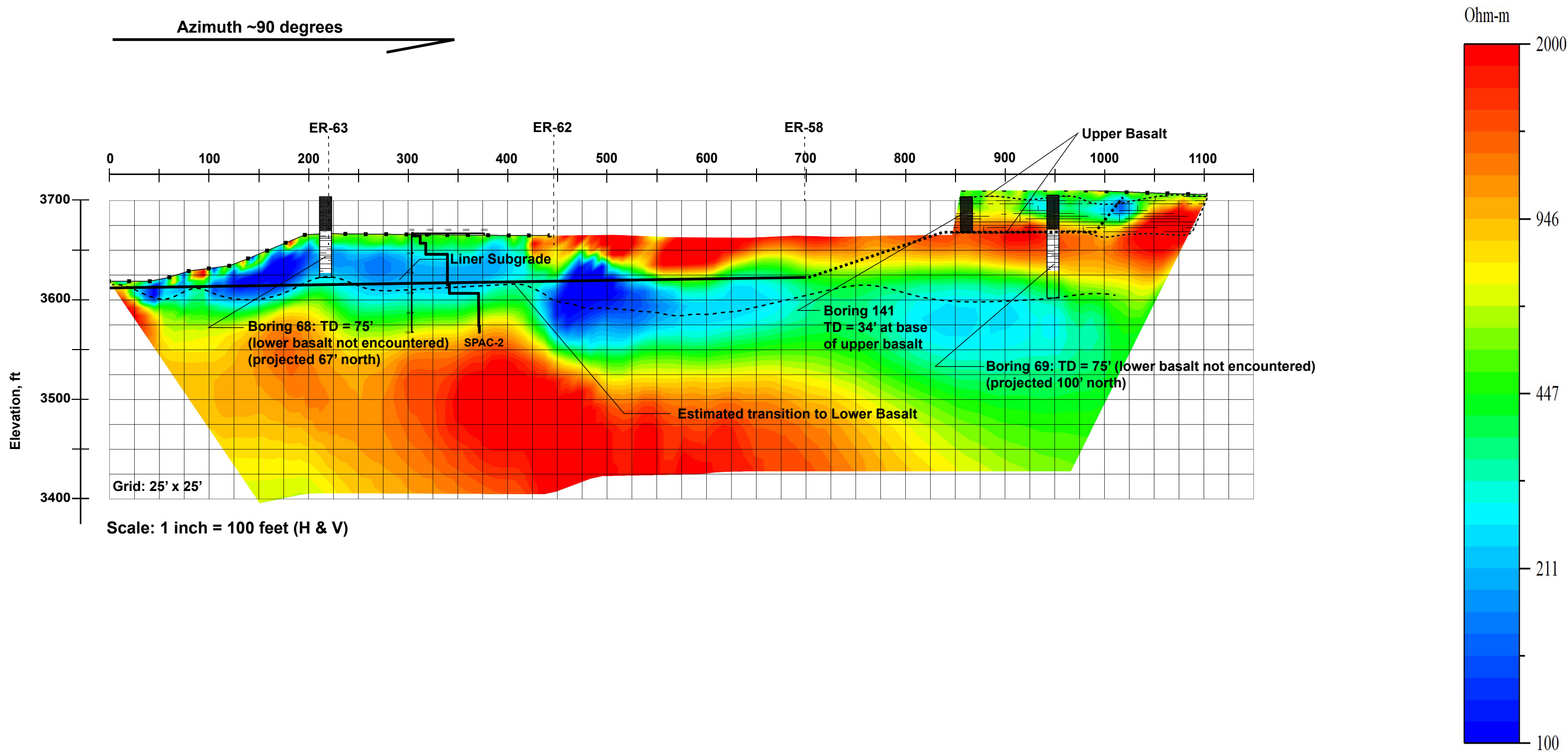

Note: boring data are from historic surveys at Knott Landfill and presented as additional information bearing on this project

Electrical Resistivity Tomography: ER-60	Figure: ER-60
Knott Landfill Cell 9 Deschutes County, Oregon	September 8, 2021 Project # 210021
Prepared for: G. Friesen Associates, Inc.	updated August 2023
	Siemens & Associates

Electrical Resistivity Tomography: ER-61

(56 electrodes on 6.25 m spacing: combined Dipole-Dipole, inverted Schlumberger and Strong Gradient arrays)

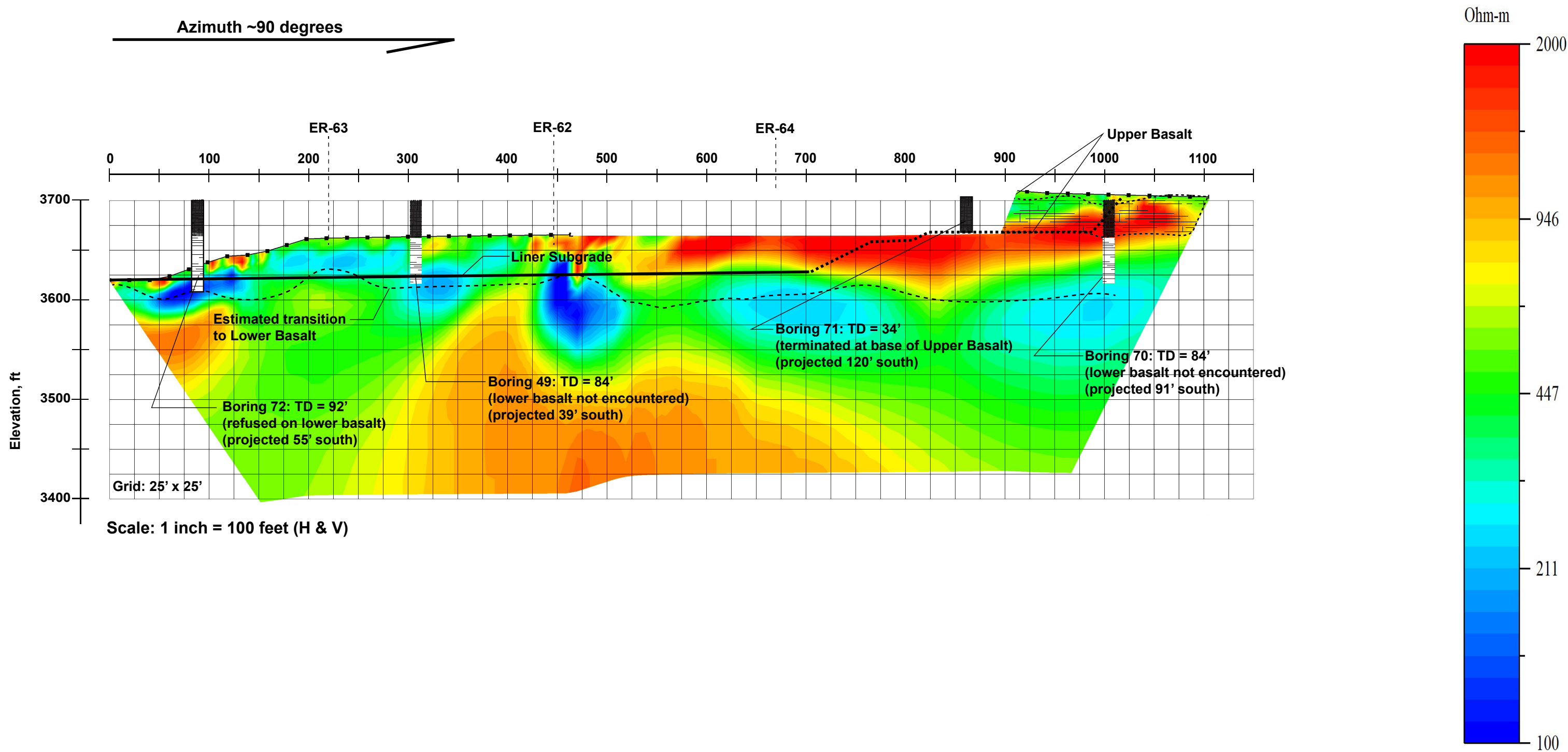

Note: boring data are from historic surveys at Knott Landfill and presented as additional information bearing on this project

Electrical Resistivity Tomography: ER-61	Figure: ER-61	
Knott Landfill Cell 9 Deschutes County, Oregon	September 8, 2021	Project # 210021
Prepared for: G. Friesen Associates, Inc.	updated August 2023	
	Siemens & Associates	

Electrical Resistivity Tomography: ER-62

(45 electrodes on 6.25 m spacing: combined Dipole-Dipole, inverted Schlumberger and Strong Gradient arrays)

Azimuth ~180 degrees

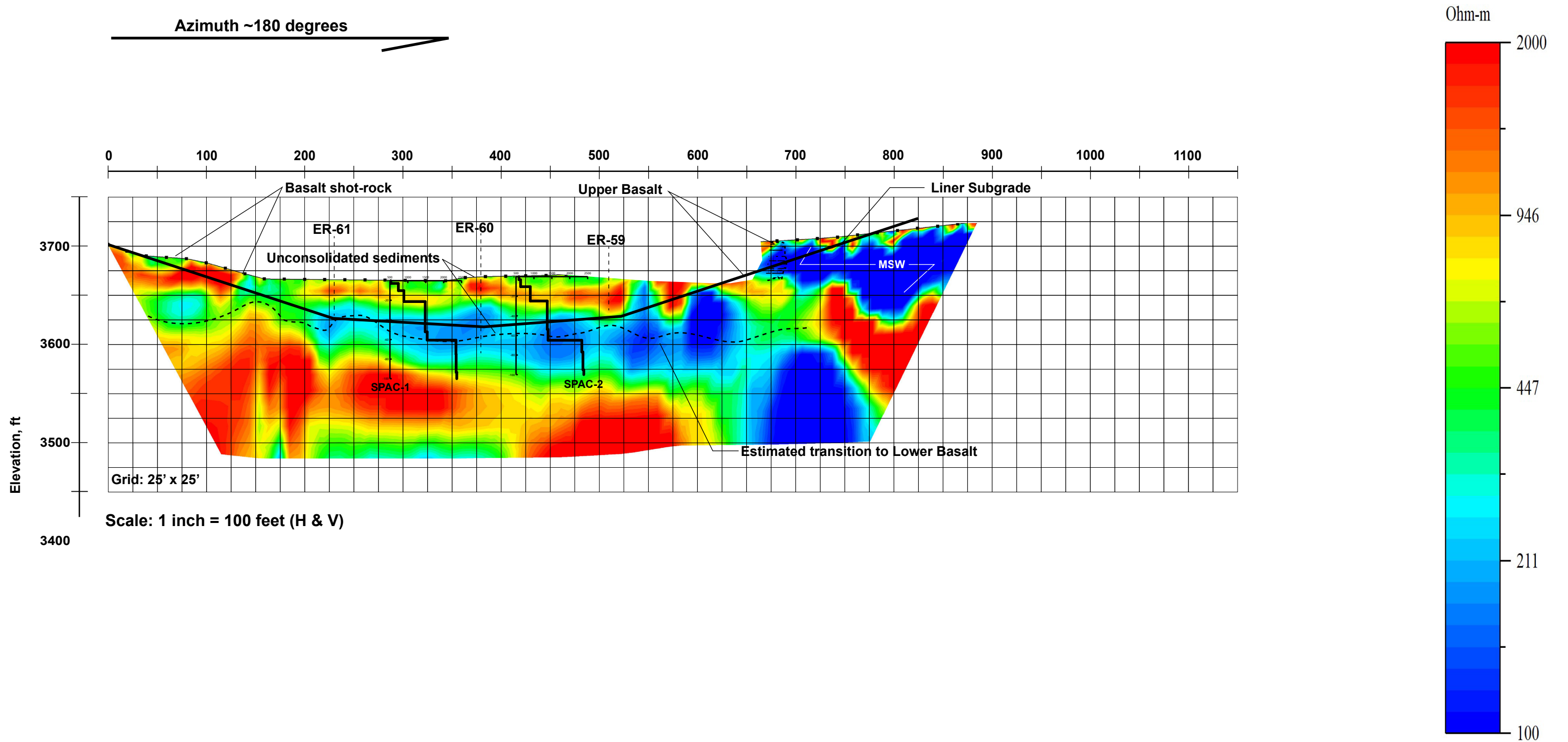

Electrical Resistivity Tomography: ER-62

Figure: ER-62

Knott Landfill Cell 9
Deschutes County, Oregon

September 13, 2021 Project # 210021

updated August 2023

Prepared for: G. Friesen Associates, Inc.

Siemens & Associates

Electrical Resistivity Tomography: ER-63

(45 electrodes on 6.25 m spacing: combined Dipole-Dipole, inverted Schlumberger and Strong Gradient arrays)

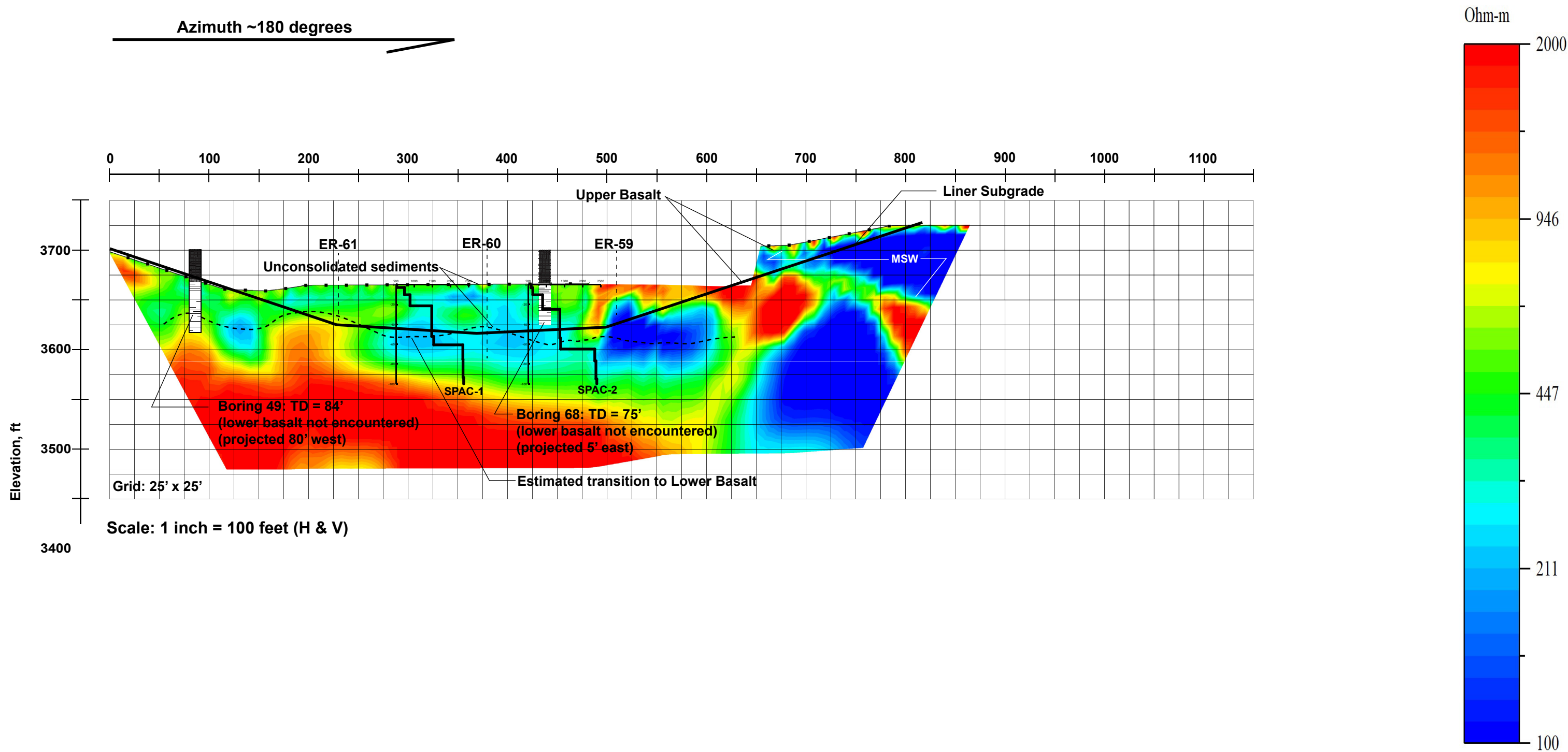

Note: boring data are from historic surveys at Knott Landfill and presented as additional information bearing on this project

Electrical Resistivity Tomography: ER-63	Figure: ER-63
Knott Landfill Cell 9 Deschutes County, Oregon	September 13, 2021 Project # 210021
Prepared for: G. Friesen Associates, Inc.	updated August 2023
	Siemens & Associates

Electrical Resistivity Tomography: ER-64

(39 electrodes on 4 m spacing: combined Dipole-Dipole, inverted Schlumberger and Strong Gradient arrays)

Azimuth ~169 degrees

Ohm-m

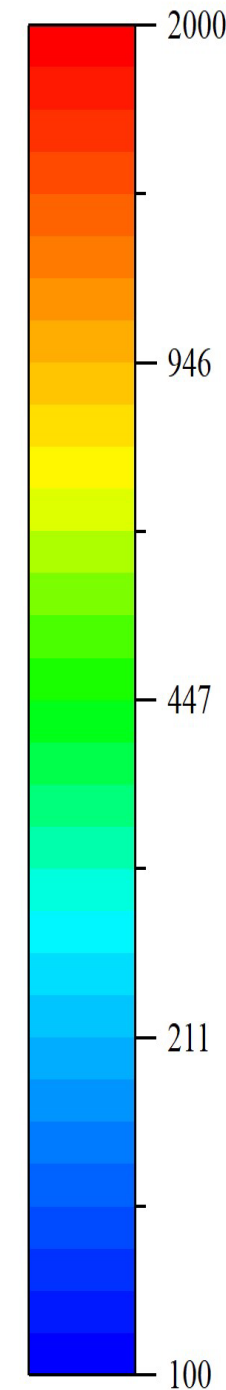

0 100 200 300 400 500 600 700 800 900 1000 1100

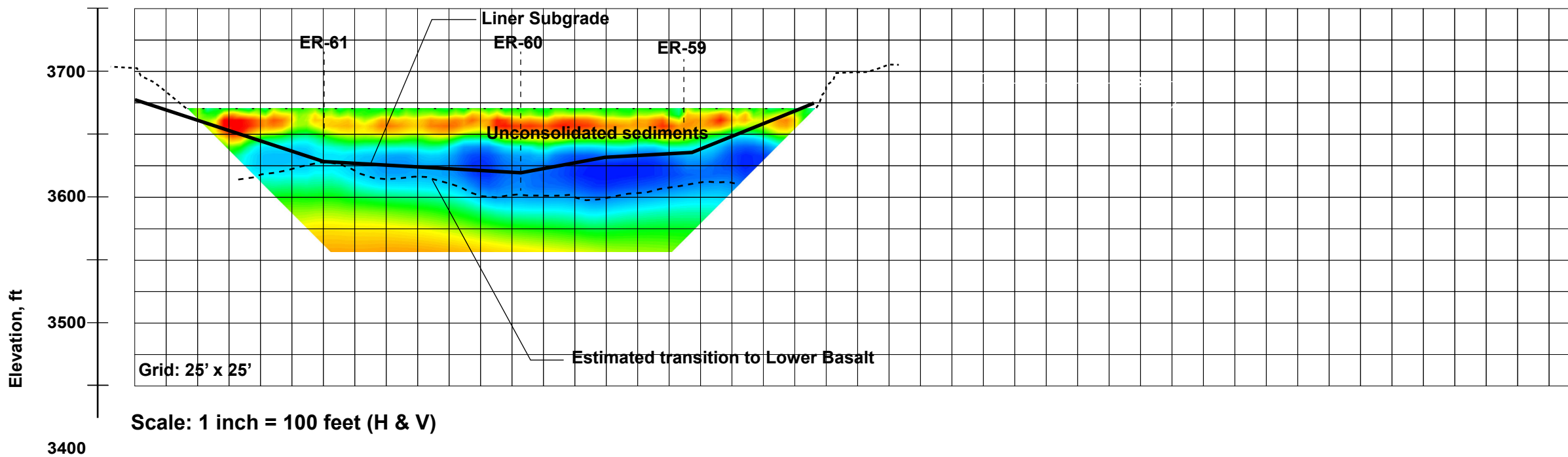

Electrical Resistivity Tomography: ER-64	Figure: ER-64	
Knott Landfill Cell 9 Deschutes County, Oregon	August 21, 2023	Project # 210021
Prepared for: G. Friesen Associates, Inc.	Siemens & Associates	

3D-1: Electrical Resistivity Tomography in 3D, southwest area of Cell 9

(26 electrodes on 4 m spacing: combined Dipole-Dipole, inverted Schlumberger and Strong Gradient arrays)

Grid: 10' x 10' (H : V)

Scale: 1 inch = 40 feet (H), 1 inch = 30 feet (V)

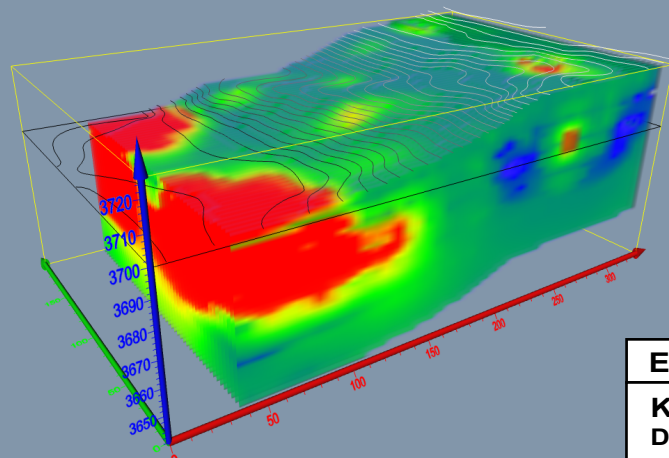
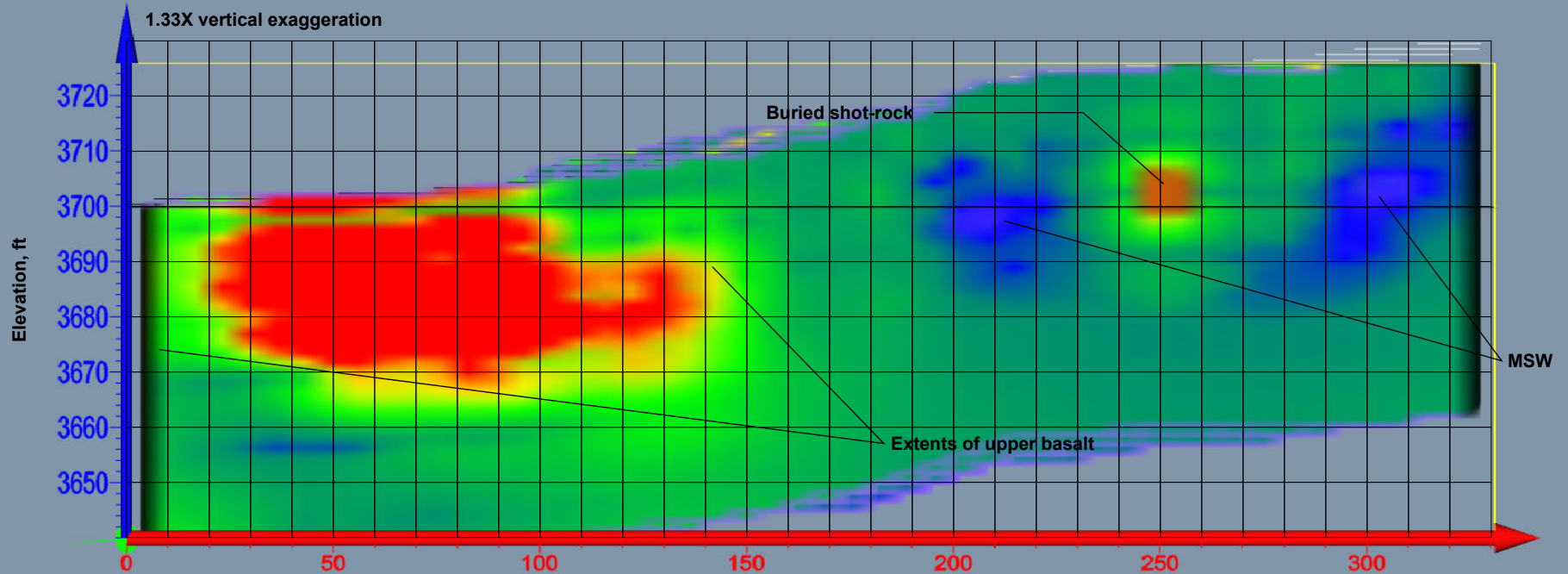

3D block perspective

Electrical Resistivity Tomography: 3D Grid West Edge
Knott Landfill Cell 9
Deschutes County, Oregon
 Prepared for: G. Friesen Associates, Inc.

Figure: 3D-1	Project # 210021
September 2, 2021	
Siemens & Associates	

3D-2: Electrical Resistivity Tomography in 3D, southwest area of Cell 9

(26 electrodes on 4 m spacing: combined Dipole-Dipole, inverted Schlumberger and Strong Gradient arrays)

Grid: 10' x 10' (H : V)

Scale: 1 inch = 40 feet (H), 1 inch = 30 feet (V)

1.33X vertical exaggeration

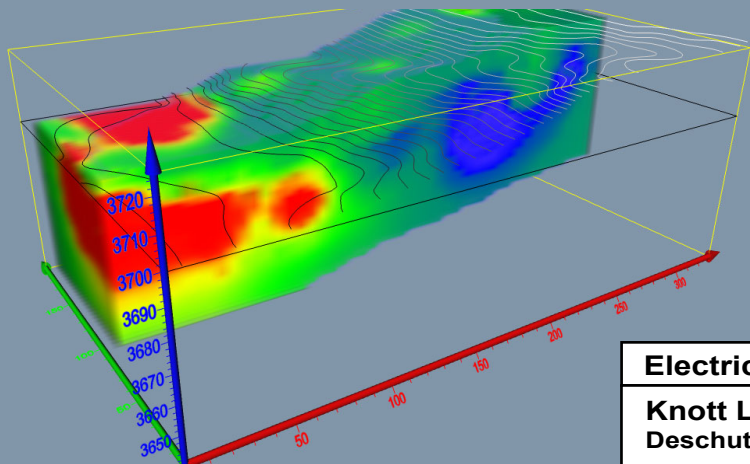
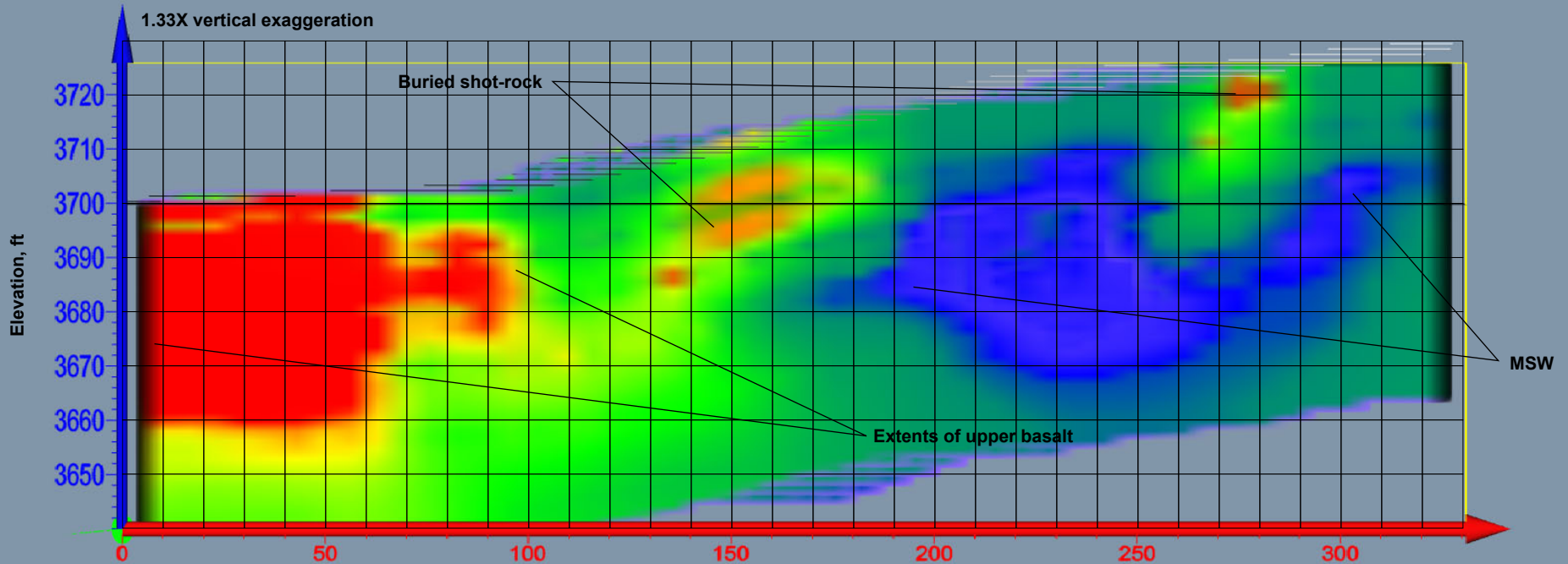

3D block perspective

Electrical Resistivity Tomography: 3D Grid West Edge

Knott Landfill Cell 9
Deschutes County, Oregon

Prepared for: G. Friesen Associates, Inc.

Figure: 3D-2

September 2, 2021

Project # 210021

Siemens & Associates

3D-3: Electrical Resistivity Tomography in 3D, southwest area of Cell 9

(26 electrodes on 4 m spacing: combined Dipole-Dipole, inverted Schlumberger and Strong Gradient arrays)

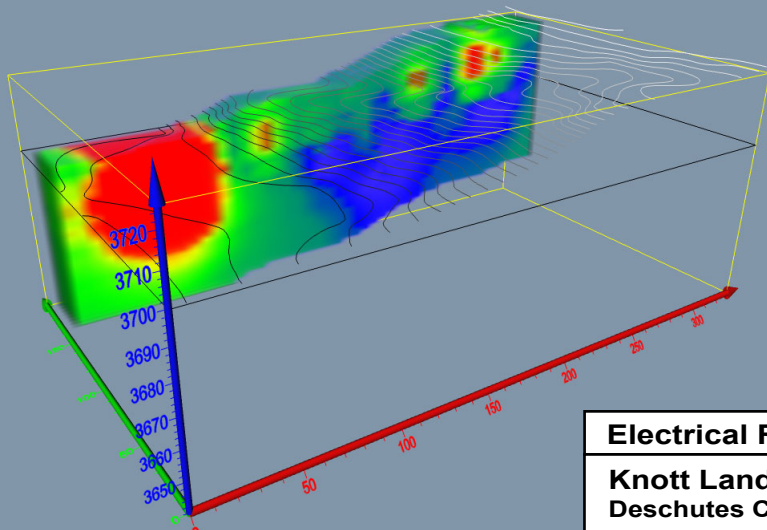
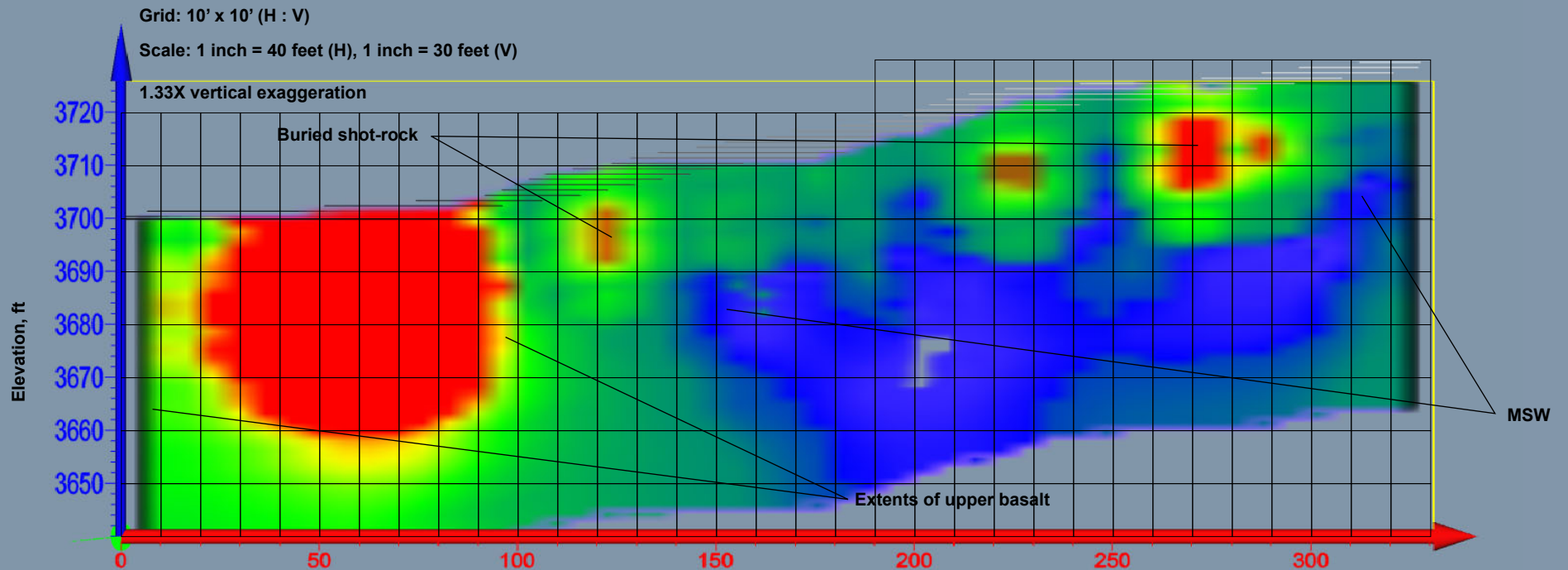

3D block perspective

Electrical Resistivity Tomography: 3D Grid West Edge

Knott Landfill Cell 9
Deschutes County, Oregon

Prepared for: G. Friesen Associates, Inc.

Figure: 3D-3

September 2, 2021

Project # 210021

Siemens & Associates

SPAC 1: Vs Model

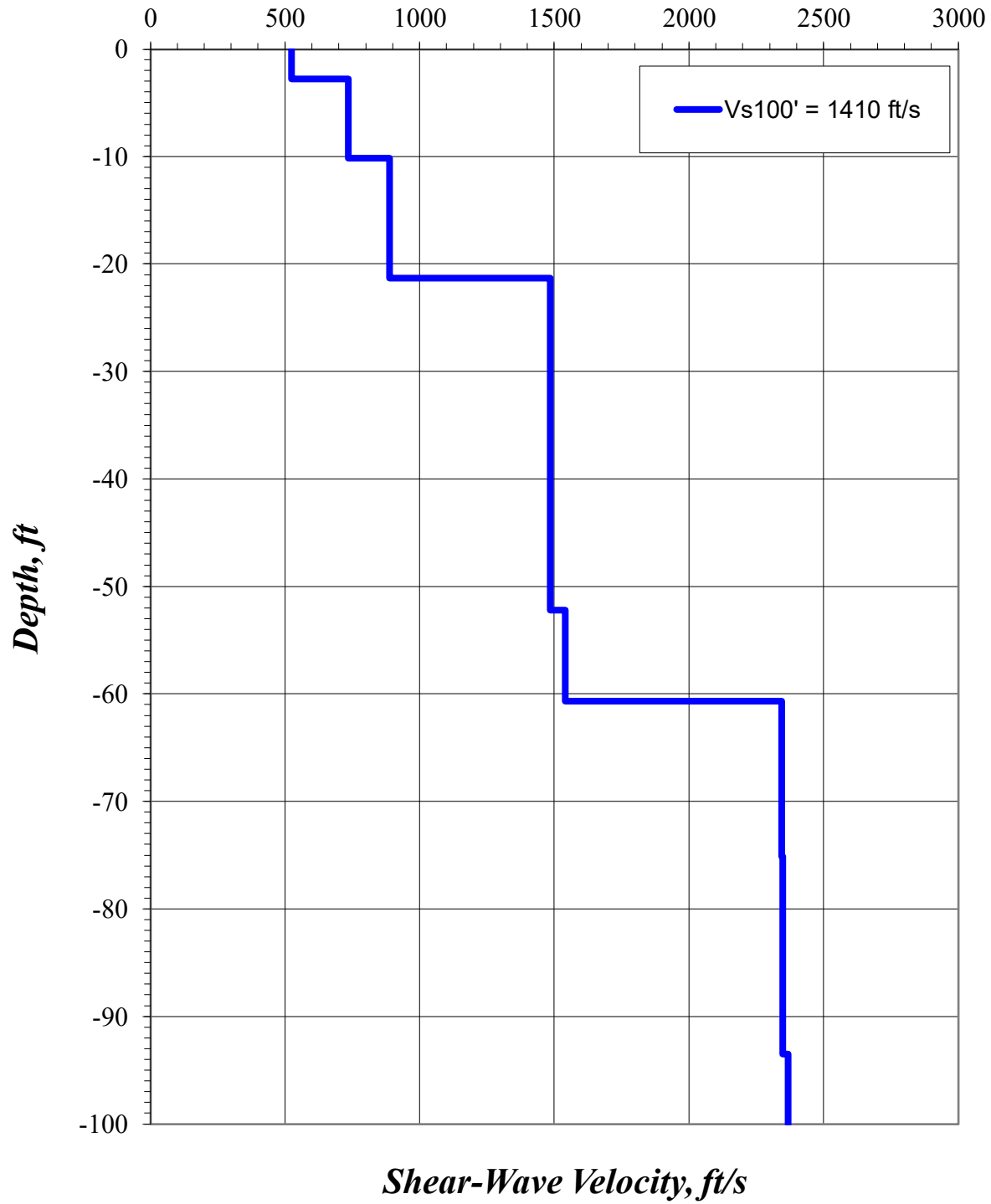

SPAC 1

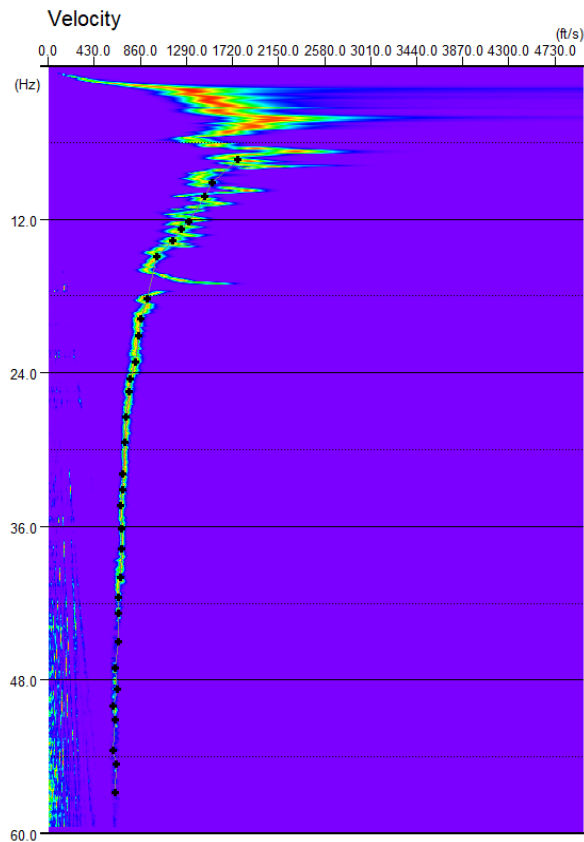
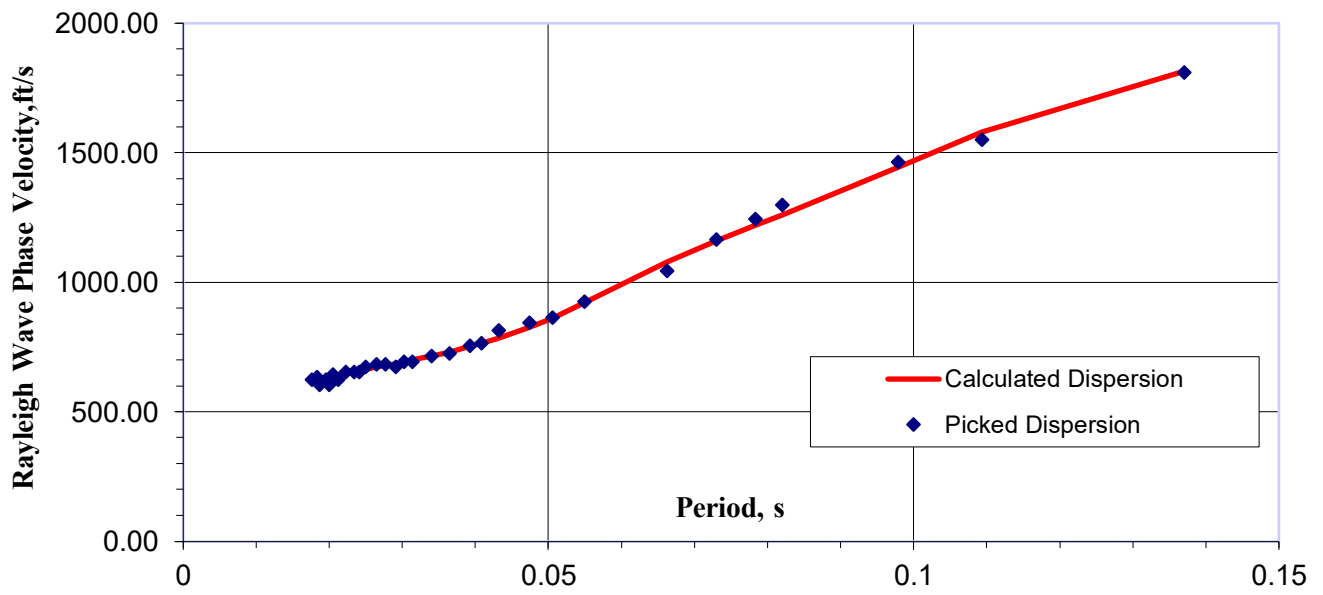

SPAC 2: Vs Model

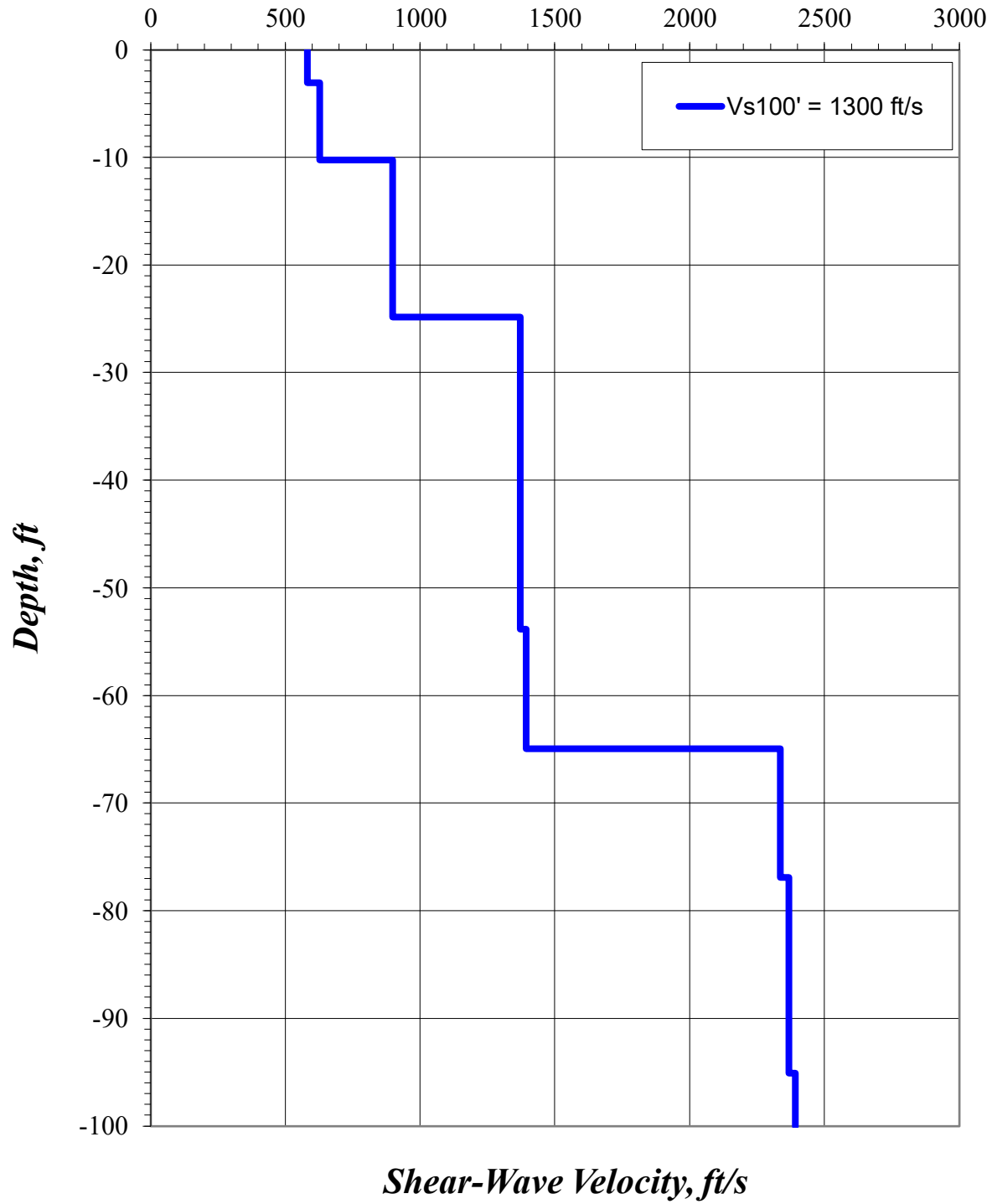

SPAC 2

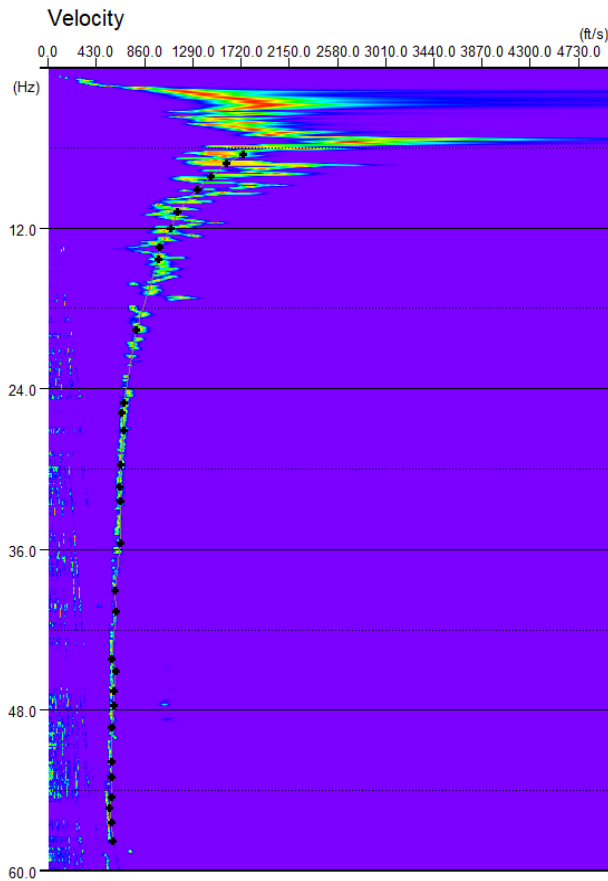
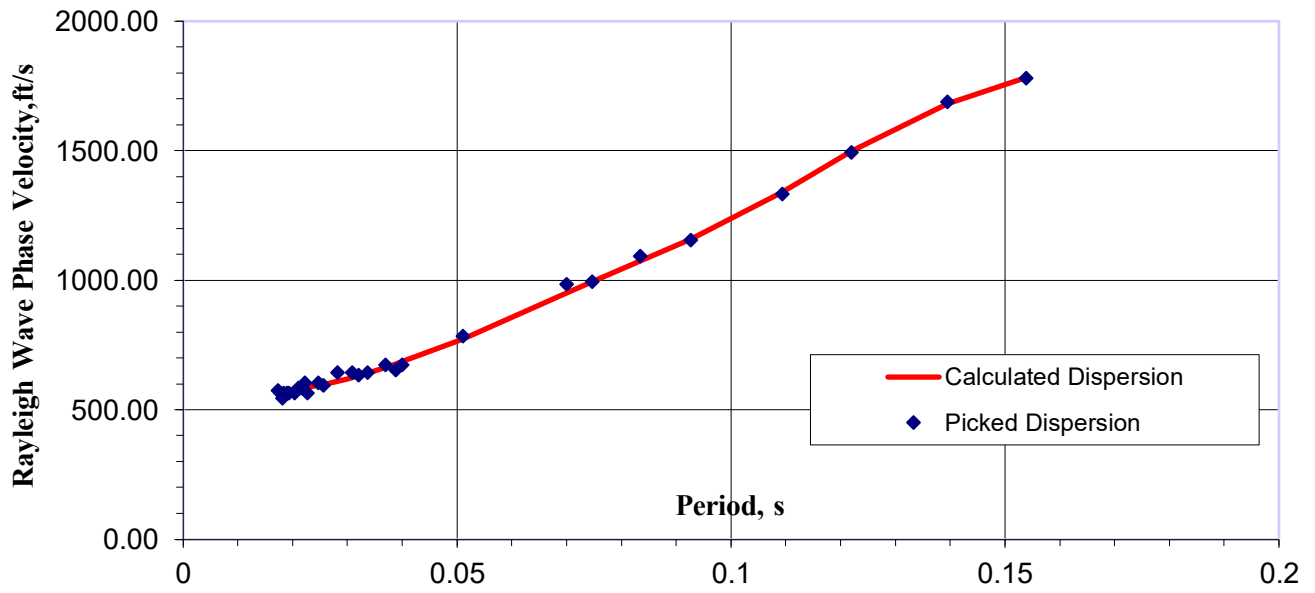

SPAC-3

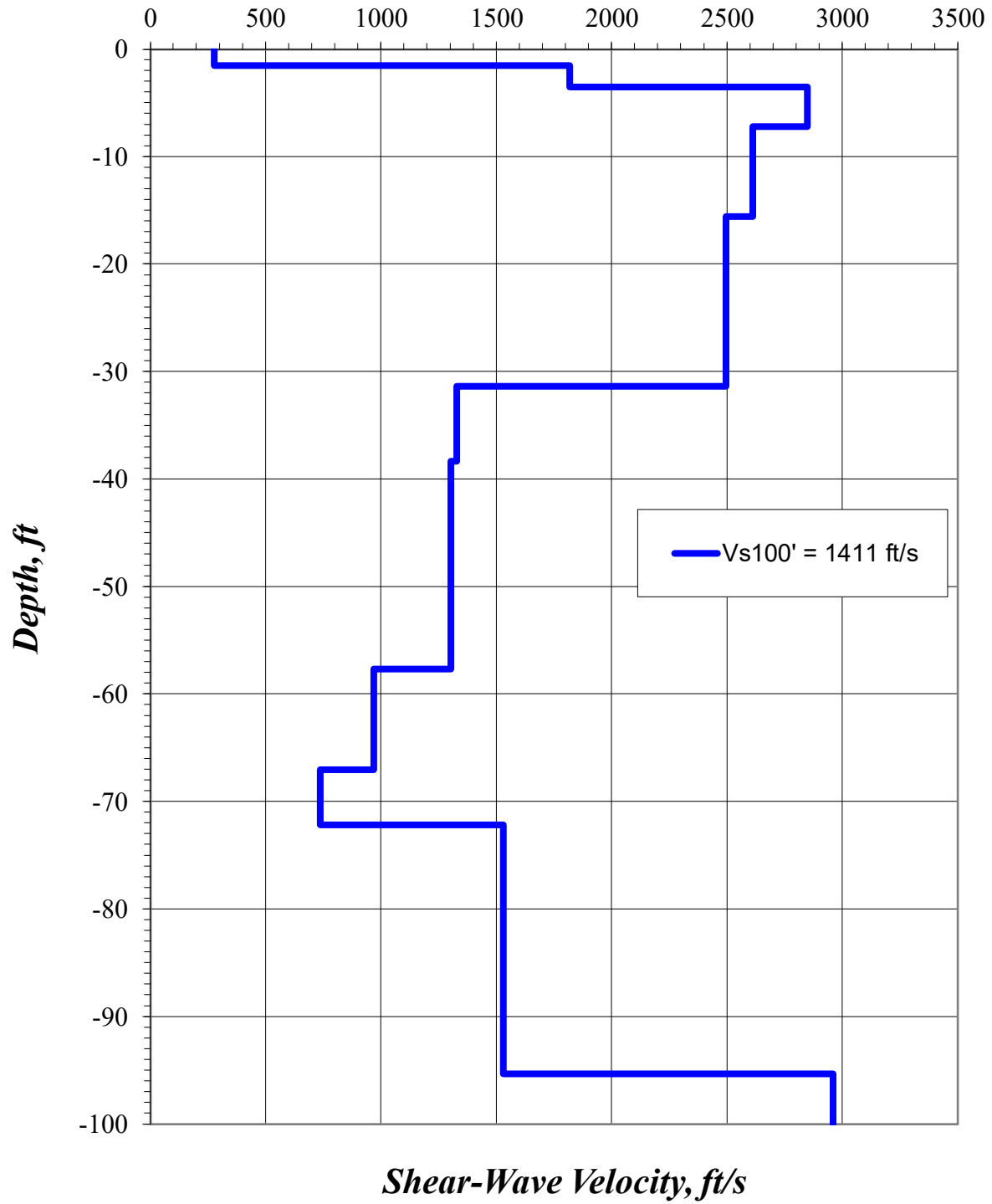

SPAC -3

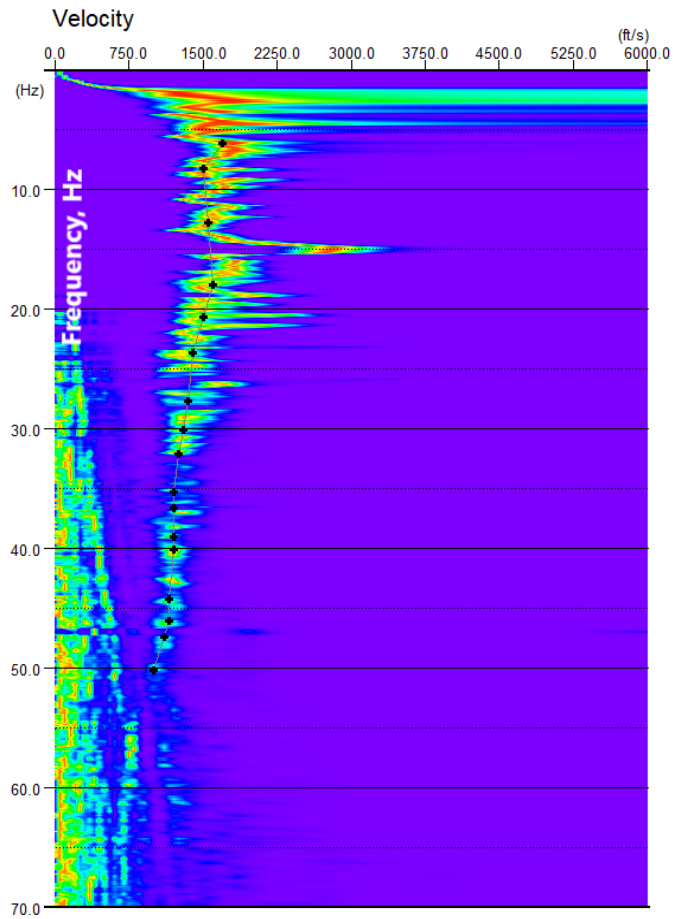
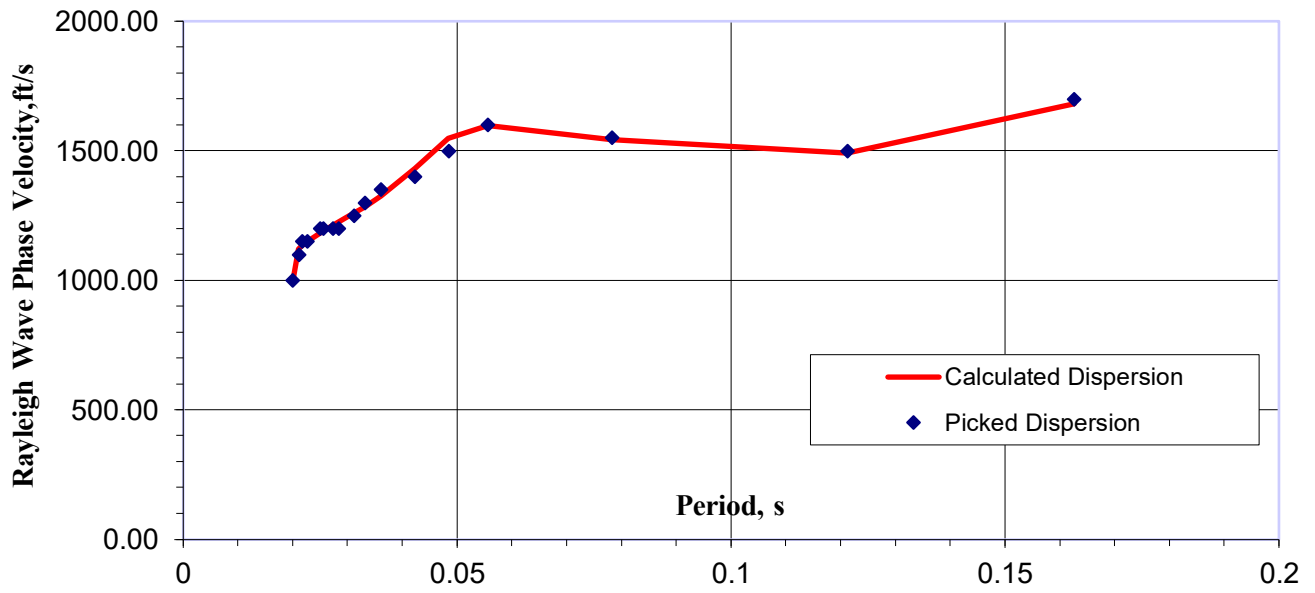

Part VIII
Conditional Use Permit
for
Crushing and Storage of Excavated Material

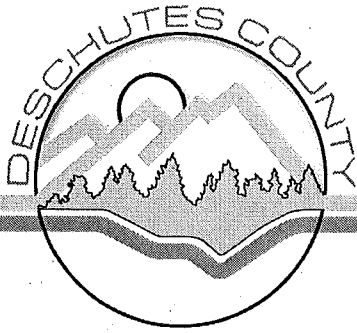

Community Development Department

Planning Division Building Safety Division Environmental Health Division

117 NW Lafayette Avenue Bend Oregon 97701-1925
(541)388-6575 FAX (541)385-1764
<http://www.co.deschutes.or.us/cdd/>

NOTICE OF CORRECTED DECISION

On September 29, 2008, the Planning Division mailed a Findings and Decision for the proposal detailed below. In that decision, staff inadvertently added language to a Finding and a Condition of Approval regarding drilling and blasting that does not correspond to the referenced approval criterion. Specifically, criterion 18.52.110(J)(2)(c) provides limits on the hours and days of operation for blasting. Staff incorrectly included drilling under this limitation. Below, staff has corrected this error via ~~strikeout~~/underline

The Deschutes County Planning Division has approved the land use application(s) described below:

- FILE NUMBER:** CU-08-61/SP-08-25
- LOCATION:** The property is located at 60800 27th Street, Bend, and is identified on County Assessor's Map 18-12-14, as Tax Lot 500.
- APPLICANT:** Deschutes County Department of Solid Waste
- SUBJECT:** The Deschutes County Planning Division has approved an application to allow processing (crushing) and stockpiling of material excavated at the Knott Landfill.
- STAFF CONTACT:** Anthony Raguine, Senior Planner, (541) 617-4739
- APPLICABLE CRITERIA:** The Planning Division reviewed this application for compliance against criteria contained in Sections 18.52.040, 18.52.050, 18.52.090, 18.52.110 and 18.52.140 of Title 18, the DCC Zoning Ordinance and the procedural requirements of Title 22 of the DCC.

DECISION: Staff finds that the application satisfies all applicable criteria, and approval is being granted subject to the following conditions:

1. This approval is based upon the site plan and information submitted by the applicant. Any substantial change in the approved plan will require a new application.
2. The applicant shall follow and meet all requirements of the site-specific ESEE analysis.
3. Any dust and noise created from the mining operation and associated activities at this site shall be controlled so as to meet applicable DEQ standards, and in such a manner as not to be a nuisance as defined in OAR 340-21-050. Watering or chemical treatment

of the roads on the site used for access shall be required where deemed necessary to prevent a nuisance. The access roads shall be maintained for safety.

4. All mining operations shall be conducted between the hours of 7:00 a.m. and 5:00 p.m., Monday through Friday. No surface mining operations shall be conducted on Saturdays, Sundays or the following legal holidays: New Year's Day, Memorial Day, July 4th, Labor Day, Thanksgiving Day, Christmas Day.
5. ~~Drilling and blasting~~ Blasting to excavate the materials shall only be allowed between the hours of 9:00 a.m. to 5:00 p.m., Monday through Friday. The applicant shall send the required notice under section 18.52.110(J)(2)(d) for the drilling and blasting.
6. Any exterior lighting used for the surface mining operation shall meet all requirements of Chapter 15.10, Outdoor Lighting, of the Deschutes County Code.
7. The applicant (or contractor) shall obtain an Air Contaminate Discharge Permit from the Oregon Department of Environmental Quality, and submit a copy to the Planning Division, prior to commencement of any crushing on the site. The rock crusher shall be located below natural ground level to reduce the amount of noise generated from the site, as specified on the submitted plan.
8. The existing topographic and vegetative screening for the surface mine shall be maintained and/or replaced to assure screening throughout the duration of the crushing operation.
9. Only equipment, structures and materials related to proposed surface mining shall be allowed on the surface mining site. All surface mining equipment and related structures shall be removed from the site within 30 days of completion of all mining and reclamation.
10. No onsite sales of excavated or crushed material shall be allowed for the site.

This land use permit shall be void two (2) years from the date this decision becomes final unless the permit is initiated or extended pursuant to Chapter 22.36 of the DCC.

This decision becomes final twelve (12) days after the date mailed, unless appealed by a party of interest. To appeal, it is necessary to submit a Notice of Appeal, the appeal fee of \$250.00 and a statement raising any issue relied upon for appeal with sufficient specificity to afford the Hearings Body an adequate opportunity to respond to and resolve each issue.

Copies of the application, all documents and evidence submitted by or on behalf of the applicant and applicable criteria are available for inspection at no cost. Copies can be purchased for 25 cents per page.

Pending land use applications can be accessed online at www.deschutes.org/cdd. Click on "Property Development" heading, then click on "Pending Land Use Applications" located on right side of page (opens in new window)

NOTICE TO MORTGAGEE, LIENHOLDER, VENDOR OR SELLER: ORS CHAPTER 215 REQUIRES THAT IF YOU RECEIVE THIS NOTICE, IT MUST BE PROMPTLY FORWARDED TO THE PURCHASER.

Dated this 2nd day of October 2008

Mailed this 2nd day of October 2008

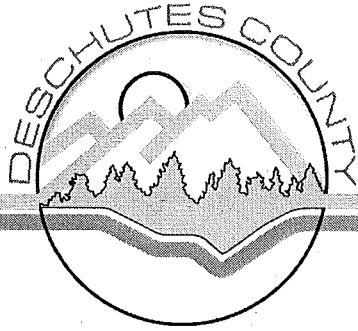

Community Development Department

Planning Division Building Safety Division Environmental Health Division

117 NW Lafayette Avenue Bend Oregon 97701-1925
(541)388-6575 FAX (541)385-1764
<http://www.co.deschutes.or.us/cdd/>

CORRECTED FINDINGS & DECISION

On September 29, 2008, the Planning Division mailed a Findings and Decision for the proposal detailed below. In that decision, staff inadvertently added language to a Finding and a Condition of Approval regarding drilling and blasting that does not correspond to the referenced approval criterion. Specifically, criterion 18.52.110(J)(2)(c) provides limits on the hours and days of operation for blasting. Staff incorrectly included drilling under this limitation. Below, staff has corrected this error via ~~strikeout~~/underline.

FILE NUMBERS: CU-08-61/SP-08-25

APPLICANT/OWNER Timm Schimke, Director
Deschutes County Department of Solid Waste
61050 SE 27th Street
Bend, OR 97702

PROPOSAL: The applicant is requesting a conditional use permit and site plan review to allow crushing and storage of excavated material at the Knott Landfill.

STAFF CONTACT: Anthony Raguine, Senior Planner

I. APPLICABLE CRITERIA:

Title 18 of the County Code, the County Zoning Ordinance:
Chapter 18.52, Surface Mining Zone – SM
Sections 18.52.020, .040, .050, .090, .110, .115, .130, .140, .170

II. BASIC FINDINGS:

- A. LOCATION:** The subject property is located at 60800 27th Street, Bend, and is identified on County Assessor map 18-12-14, as tax lot 500.
- B. ZONING:** The property is zoned Surface Mining (SM).
- C. SITE DESCRIPTION:** The subject property is approximately 135 acres in size and is the site of the County's landfill and recycling center. The topography of the site ranges from level to moderately sloping, as well as deep pits for refuse disposal. The undisturbed portions of the site have a vegetative cover of scattered juniper and ponderosa pine

trees and an understory of scrub brush and grasses. Access to the landfill site and recycling center is from a driveway off of SE 27th Street. There are several buildings on the site, including an office, storage buildings, maintenance building, weigh station building, and refuse receiving building.

The Knott landfill site has been in operation under a valid DEQ permit for approximately 36 years, since 1972.

- D. PROPOSAL:** The applicant is requesting approval of a conditional use permit and site plan review to process (crush) and store material excavated at the landfill. Based on the submitted application and a conversation with Department of Solid Waste staff, the processing and storage operation would cover an approximately 36-acre rectangle oriented lengthwise east to west within the landfill, and would be completed in two phases. The first phase would begin shortly after receiving approval, and would be located in the westerly 12 acres of the rectangle. Phase two would begin in approximately one year, and would be located in the easterly 24 acres of the rectangle. The applicant proposes the following hours of operation: Monday through Friday, 7:00 a.m. to 5:00 p.m.

Based on staff's site visit with Department of Solid Waste personnel, the crusher would be located approximately 25 feet below the level of SE 27th Street. The crusher would be located in an existing excavated area which has been leveled for this use. The proposed operation also involves the storage of crushed materials in the eastern portion of the processing rectangle. Excavated and crushed material would be loaded onto trucks for transport to the storage areas. The applicant submitted the following information in support of this application:

1. Burden of proof statement
2. Closure/Reclamation plan (Attachment A)
3. Site Plan (Attachment B)
4. DEQ General Permit for Rock Crushers (Attachment C)
5. Noise Level Comparison (Attachment D)

These materials are incorporated by reference herein.

- E. SURROUNDING LAND USE:** The surrounding area has public uses including: High Desert Middle School (approximately 825 feet to the northwest), Central Electric Cooperative Office (approximately 1,300 feet to the north), and the Humane Society facility (approximately 2,600 feet to the north). To the north of the subject site is a large vacant publicly owned block of land (18-12, tax lots 1700 and 1800, State of Oregon, 634 acres), and directly west is a vacant parcel owned by the Bend Metro Park and Recreation District (18-12-14, tax lot 200, 31.71 acres). Directly south, across Rickard Road, is a surface mining operation commonly known as the Rose Pit (Surface Mine Site No. 392, 18-12-23, tax lot 300).

To the west are High Desert Veterinary Services (18-12-15, tax lot 1901) and Bend Pet Resort (18-12-15, tax lot 200), each with an associated dwelling. The dwelling on tax lot 1901 is located approximately 1,800 feet to the southwest of the processing and storage area. The dwelling on tax lot 200 is located approximately 1,700 feet to the west. The closest dwellings to the proposed processing and storage area appear to be at least

1,200 feet to the east (18-12-14, tax lot 600) and 1,500 feet south (County Assessor map 18-12-14, tax lot 400).

The properties surrounding the subject property are zoned Exclusive Farm Use (EFU) to the north, east and south, and Urban Area Reserve (UAR) to the west. The zoning also includes the Surface Mining Impact Area (SMIA) combining zone associated with surface mining site nos. 390 and 392.

F. LOT OF RECORD: The subject property is a legal lot of record via several previously issued land use approvals, and building and septic permits.

F. PUBLIC AGENCY COMMENTS: The Planning Division sent notice of the proposal to several public agencies and received the following responses:

Deschutes County Building Division: Building permits and proper plan review would be required per 2007 OSSC Code for any structures used in this operation.

Bend Fire Department:

1. Obstruction & Protection of Fire Hydrant – 2007 Oregon IFC 508.5.4 through 508.5.6

A 3-foot clear space shall be maintained around the circumference of fire hydrants. When exposed to vehicular damage, concrete curbing, sidewalks, or 4 inch concrete filled bollards placed 3 feet from hydrants shall suitably protect fire hydrants. Hydrants shall be coated with approved red paint color and markings.

2. Premises Identification - 2007 Oregon IFC 505.1

Approved numbers or addresses shall be placed on all new and existing buildings in such a position as to be plainly visible and legible from the street or road fronting the property. Said numbers shall contrast with their background and visible at night. Dwellings and Foster Homes that are located off of street frontage shall post a visible approved reflective address sign at the entrance to their driveway. (Signs are available at local Fire Stations)

3. Street or Road Signs - 2007 Oregon IFC 505.2

Streets and roads shall be identified with approved signs. Signs shall be of an approved size and weather resistive construction.

4. Fire Lanes - 2007 Oregon IFC 503.3

Approved signs or other approved notices shall be provided for fire apparatus access roads to identify such roads or prohibit the obstruction thereof. Such signs or notices shall be kept in legible condition at all times. Fire lane curbs shall be painted bright red with white letters. The stroke shall be 1 inch with letters 6 inches high to read "No Parking Fire Lane". Spacing for signage shall be every 50 feet.

5. Portable Fire Extinguishers - 2007 Oregon IFC Section 906

Fire extinguisher ratings and travel distances shall not be less than that specified in Tables 906.3(1) and 906.3(2) of Section 906. Portable fire extinguishers shall be selected, installed and maintained in accordance with Section 906 and NFPA

10. Additional portable fire extinguishers may be required by the applicable code sections found in Table 906.1.

6. **Key Boxes - 2007 Oregon IFC Section 506**

Key Box (Knox Box) for Fire Department access is required to be installed at all locked access gates and barriers. An application for the Knox Box is available by calling the Fire Prevention office at (541) 322-6309.

7. **Gas Meters & Piping - 2007 Oregon IFC Section 312**

Aboveground gas meters, regulators and piping exposed to vehicular damage due to proximity to alleys, driveways or parking areas shall be protected in an approved manner.

The following agencies did not respond, or responded with no comment: County Assessor, County Environmental Health Division, and County Road Department.

G. **PUBLIC NOTICE AND COMMENTS:** The Planning Division sent written notice of this administrative action to property owners within 250 feet of the subject property. A response was received from Bob and Karen Marcotte on August 13, 2008 (included herein by reference). The letter identifies the following issues:

1. Crushing, sorting, and blasting outside of the approved operational hours
2. Dust control should be required
3. Odor from the landfill
4. Bird feces

I. **REVIEW PERIOD:** This application was submitted on July 30, 2008, and deemed complete on August 29, 2008. The 150th day upon which the County must take action on this application is January 26, 2009.

J. **POSTED NOTICE:** The applicant submitted a land use action sign affidavit dated August 7, 2008 indicating that the sign was posted on the same day.

III. **CONCLUSIONARY FINDINGS:**

A. **Chapter 18.52, Surface Mining Zone – SM**

1. Section 18.52.020, Application of ordinance.

Except as provided in DCC 18.52.160, the setbacks, operation standards and conditions set forth in DCC 18.52.090, 18.52.110 and 18.52.140, respectively, apply to every surface mining site and activity to the extent that setbacks, standards and conditions are not expressly provided for in the site-specific ESEE analysis within the surface mining element of the Comprehensive Plan. When there is a conflict between the site-specific ESEE analysis and the provisions of DCC 18, the site-specific ESEE analysis shall control.

FINDING: The proposed conditional use and site plan review applications are subject to sections 18.52.050, 18.52.070, 18.52.080, 18.52.090, 18.52.110 and 18.52.140, which

the applicant has addressed in the burden of proof statement. The ESEE analysis is addressed in findings below.

2. Section 18.52.040, Uses permitted outright subject to site plan review.

The following uses are permitted outright subject to site plan review as provided in this section:

- A. Extraction of minerals.**
- B. Stockpiling and storage of minerals.**
- C. Screening, washing and sizing of minerals.**
- D. Sale of minerals and mineral products extracted and produced on the parcel or contiguous parcels in the same ownership.**
- E. Buildings, structures, apparatus, equipment and appurtenances necessary for the above uses to be carried on.**

FINDING: The applicant is proposing a surface mining operation that consists of processing (crushing) and storage of extracted material on-site. Applicable approval criteria related to processing and storage are addressed below.

The material would be excavated from areas to be used for future landfill operations, and then crushed and stored on-site, and used to backfill the landfill area. No sales of the mineral products produced on the site would occur. The applicant has not indicated that any buildings or structures are proposed as part of the operation. Apparatus and equipment would be used to extract and process the minerals, including a rock crusher.

3. Section 18.52.050. Conditional uses permitted.

B. The following uses are permitted subject to site plan review and the setbacks, standards and conditions set forth in DCC 18.52.090, 18.52.110 and 18.52.140, respectively, and are not subject to the conditions in DCC 18.128:

...

- 2. Crushing of mineral and aggregate materials on sites designated for crushing in the ESEE analysis in the surface mining element of the Comprehensive Plan.**

FINDING: The applicant is proposing to crush aggregate minerals on the site. The ESEE analysis for site no. 390, item 23, Program to Meet the Goal, states, "The Board finds that processing on site will be allowed." Processing includes the crushing of minerals as listed under section 18.04.030, Definition – Surface mining, processing. Consequently, the crushing of minerals on the site can be allowed if the conditional use criteria are met. The proposal's conformance with the conditional use criteria is addressed below.

4. Section 18.52.090. Minimum use setbacks.

A. Except as otherwise provided in this section, all surface mining activities and uses, including structures, shall be located and conducted at least 250 feet from a noise-sensitive or dust-sensitive use or structure. Exceptions to this standard shall be allowed....

- B. Storage and processing of mineral and aggregate material, and storage of operational equipment which creates noise and dust, shall not be allowed closer than one-quarter mile from any noise or dust sensitive use or structure existing on the effective date of Ordinance No. 90-014, unless the applicant demonstrates that....**

FINDING: Deschutes County Code, Section 18.04, provides the following definitions of dust-sensitive and noise-sensitive uses:

Dust-sensitive use means real property normally used as a residence, school, church, hospital or similar use. Property used in industrial or agricultural activities is not "dust-sensitive" unless it meets the above criteria in more than an incidental manner. Accessory uses such as garages and workshops do not constitute dust-sensitive uses.

Noise-sensitive use means real property normally used for sleeping or normally used as schools, churches, hospitals or public libraries. Property used in industrial or agricultural activities is not "noise-sensitive" unless it meets the above criteria in more than an incidental manner. Accessory uses such as garages or workshops do not constitute noise-sensitive uses.

Based on staff's review of the submitted site plan and a 2005 aerial photograph, the 36-acre processing and storage area would be located approximately 825 feet from High Desert Middle School, the closest dust- or noise-sensitive use. However, the first building permit for the school was not issued until 1992, after the effective date of Ordinance 90-014 on July 16, 1990. Therefore, High Desert Middle School is not protected by criterion 'B' above.

The next closest dust- or noise-sensitive use is the dwelling located approximately 1,200 feet east of operations area, and identified on Assessor map 18-12-14, as tax lot 600. County records indicate a manufactured home permit (MH11036) was issued to tax lot 600 on March 11, 1991, after the effective date of Ordinance 90-014. Similar to High Desert Middle School, the dwelling on tax lot 600 is not protected by criterion 'B' above.

All other dust- and noise-sensitive uses are located over 1/4-mile (1,320 feet) from the processing and storage area. These criteria would be met.

5. Section 18.52.110, General operational standards.

Prior to the start of any surface mining activity and no later than site plan review if such review is required under this section, the applicant shall demonstrate that the following standards are or can be met by the surface mining operation:

A. Access.

1. **All on-site roads used in the mining operation, and access roads from the site to a public road maintained by a government agency, are designed and constructed to accommodate the vehicles and equipment which will use them, and shall meet the following minimum standards:**

- a. **All access roads within 100 feet of a paved county road or state highway are paved unless the applicant demonstrates that other methods of dust control, including application of**

oil or water, will be implemented in a manner which provides for the safety and maintenance of the county road or state highway.

- b. Roads within the surface mining parcel which are used as part of the surface mining operation are constructed and maintained in a manner by which all applicable DEQ standards for vehicular noise control and ambient air quality are or can be satisfied.*
- c. All roads used for mining are paved and will be adequately maintained at all points within 250 feet of a dwelling or other dust-sensitive use existing on the effective date of Ordinance No. 90-014.*

FINDING: The applicant is not proposing any changes to the access roads/driveways into the landfill site. The existing access road from 27th Street is paved to a point beyond the weigh station, exceeding the 100-foot requirement in criterion 'a' above. Within the areas of extraction, processing, and storage, the access roads are a combination of dirt and gravel. The applicant's burden of proof indicates that all unpaved roads on-site are treated for dust suppression through the application of a chemical dust suppressant or water applied by a water truck. The applicant states that the site is regulated by the DEQ through a disposal permit which includes dust and noise standards. As noted above, no dust- or noise-sensitive uses are located closer than 800 feet from the proposed operations area. These criteria would be met.

- 2. Improvements or fees in lieu of improvements of public roads, county roads and state highways may be required when the Planning Director or Hearings Body, in consultation with the appropriate road authority, determines that the increased traffic on the roads resulting from the surface mining activity will damage the road sufficiently to warrant off-site improvements. If a fee in lieu of improvements is required, the amount of the fee shall reflect the applicant's prorate share of the actual total cost of the capital expenditure of the road construction or reconstruction project necessitated by and benefiting the surface mining operation. Discounts for taxes and fees already paid for such improvements, such as road taxes for vehicles and for property already dedicated or improved, shall be applied.*

FINDING: A notice of the application was sent to the Road Department. No comment or request for road improvements was submitted.

B. Screening.

- 1. The site is screened to meet the standards specified in DCC 18.52.110(B)(2), unless one of the exceptions in DCC 18.52.110(B)(6) applies.*
- 2. Performance Standard. When screening is required by paragraph (1), it obscures the view of the screened uses from the protected uses with the methods and to the extent described in paragraph (5) below.*
- 3. Protected Uses.*

- a. *Noise-sensitive or dust-sensitive uses existing on the effective date of Ordinance No. 90-014.*
 - b. *Public parks and waysides.*
 - c. *Frontage on roads designated by the Comprehensive Plan as collectors, arterials and highways.*
 - d. *Areas zoned Landscape Management Combining.*
 - e. *Those portions of state and federal scenic waterways from which the surface mining activity is visible from the perspective of a person standing at the high water mark on either bank of the waterway.*
4. **Screened Uses.**
- a. *All equipment stored on the site.*
 - b. *All crushing and processing equipment.*
 - c. *All excavated areas except: Areas where reclamation is occurring; roadways existing on the effective date of Ordinance No. 90-014; new roadways approved as part of the site plan; material excavated to create berms; and material excavated to change the level of the mining site to an elevation which provides natural screening.*
5. **Types of Screening.**
- a. *Natural Screening. Existing vegetation or other landscape features which are located on the surface mining site within 50 feet of the boundary of the site, and which obscure the view of the screened uses from the protected uses, shall be preserved and maintained.*
 - b. *Supplied Screening. Supplied vegetative screening is screening not already existing and which is added to the site, such as hardy plant species. Plantings shall not be required to exceed either a density of six feet on center or a height of six feet at the commencement of mining. Supplied earthen screening shall consist of berms covered with earth and stabilized with ground cover.*

FINDING: As detailed in previous findings, there are several dust- and noise-sensitive uses in the vicinity of the landfill. According to county records, the closest dwellings which were existing on July 16, 1990, the effective date of Ordinance 90-014, are identified on Assessor map 18-12-14, as tax lot 400, and 18-12-15, as tax lot 200. The dwelling on tax lot 400 was established in 1974 and is located approximately 1,700 feet to the southwest. The dwelling on tax lot 200 was established in 1986 and is located approximately 1,500 feet to the south. Those two uses are considered protected uses under criterion '3.a' above. Under criterion '3.b' above, 27th Street would be considered a protected use because it is classified as an arterial roadway.

The existing screening on-site includes the height of the landfill areas, the fenced portion of the landfill site, and the landscaped retaining wall along 27th Street and Rickard Road. Additionally, the crusher would be located approximately 25 feet below the ground surface. For these reasons, staff finds that the processing area and related equipment would be screened to comply with criterion 'B'.

6. **Exceptions. Supplied screening shall not be required when and to the extent that any of the following circumstances occurs:**

- a. *The natural topography of the site offers sufficient screening to meet the performance standard in DCC 18.52.110(B)(2).*
- b. *Supplied screening cannot meet the performance standard in DCC 18.52.110(B) (2) due to topography.*
- c. *The applicant demonstrates that supplied screening cannot reliably be established or cannot survive for a 10 year period due to soil, water or climatic conditions.*
- d. *Screened uses that are visible from the protected uses will be concluded and will either be removed or reclaimed within 18 months.*
- e. *The surface miner and the owner or authorized representative of the owner of the protected use execute and record in the Deschutes County Book of Records a mitigation agreement that waives screening requirements and describes and adopts and alternate program or technique.*

FINDING: As noted above, only the dwellings on tax lots 200 and 400 are considered protected uses requiring screening. According to the applicant, the stockpile of crushed material would reach a height of approximately 20-25 feet. Given the intervening mature tree cover, staff is uncertain if the stockpile would be visible from tax lot 200. Staff finds it likely that a portion of the stockpile would be visible from tax lot 400 because there is little topographic screening available. Staff finds that no additional supplied screening of the stockpile area would be required based on the fact that supplied screening would not meet the performance standard under 18.52.110(B) due to topography.

- 7. *Continued Maintenance. Vegetative screening shall be maintained and replaced as necessary to assure the required screening throughout the duration of the mining activity.*

FINDING: The applicant does not propose any changes to the landscaped retaining wall along 27th Street and Rickard Road. The applicant shall be required to maintain this vegetative screening.

- C. *Air Quality. The discharge of contaminants and dust created by the mining operation and accessory uses to mining does not exceed any applicable DEQ ambient air quality and emissions standards.*

FINDING: The applicant has stated that the contractor providing crushing services holds a DEQ permit that would be used to comply with air quality standards. Fugitive dust is not permitted to create a nuisance. A condition of approval would require that the applicant meet all DEQ air contaminant requirements, including the air quality permit for the crusher.

- D. *Erosion Control. Sedimentation and erosion resulting from the mining operation does not affect any perennial stream so as to violate DEQ's water quality standards.*

FINDING: The applicant correctly states in the burden of proof statement that there are no perennial streams on or near the surface mining site.

E. Streams and drainage. Unless agreed to, in writing, by the adjoining property owner(s), existing natural drainages on the site are not changed in a manner which substantially interferes with drainage patterns on adjoining property or which drains waste materials or waste water onto adjoining property or perennial streams. Where the surface mining site abuts a lake, perennial stream or other perennial body of water....

FINDING: The applicant indicates that all surface water is managed on the site, and that no storm water from mining operations leaves the site. There are no bodies of water on the subject property.

F. Equipment Removal. All surface mining equipment and related structures will be removed from a mining site within 30 days of completion of all mining and reclamation.

FINDING: The applicant states that the terms of the contract with the rock crushing contractor require the timely removal of equipment upon completion of the project. This has been added as a condition of approval.

G. Flood Plain. Any mining operations conducted in a flood plain....

FINDING: No mapped flood plains exist on-site. Therefore, this criterion does not apply.

H. Noise. Noise created by a mining operation, vehicles, equipment or accessory uses which is audible off the site does not exceed DEQ noise control standards, due to topography or other natural features, or by use of methods to control and minimize off-site noise, including, but not limited to: Installation of earth-berms; placing equipment below ground level; limiting hours of operation; using a size or type of vehicle or equipment which has been demonstrated to meet applicable DEQ noise control standards; relocation of access roads, and other measures customarily used in the surface mining industry to meet DEQ noise standards.

FINDING: The proposed crushing and stockpiling operation would include vehicles and equipment that would create noise audible off of the site. The closest noise-sensitive use is High Desert Middle School, which is approximately 825 feet northwest of the proposed processing and stockpiling area. The closest dwelling to the proposed operation would be approximately 1,200 feet east. In addition, Department of Solid Waste staff indicate that a 3:1 slope must be maintained within the processing pit. As noted above, the crusher would be located approximately 25 feet below grade. Given the 3:1 slope within the pit, the crusher would be located an additional 75 feet away from the closest points of the operations area to the noise-sensitive uses identified above. Therefore, the school and dwelling would be located approximately 900 and 1,275 feet away, respectively.

The applicant has submitted a noise comparison which lists the sound level of a crusher at approximately 86 decibels (db); staff has previously found that trucks also have approximately the same db rating. Using the noise attenuation formula of $20 \log D/50$ (D = distance from mining site), and the estimated noise level of the equipment used at the site of 86 db, the expected noise level at the school would be approximately 61 dBA (20

$\log 900/50 = 25$; $86 - 25 = 61$). The expected noise level at the closest dwelling would be 58 ($20 \log 1,275/50 = 28$; $86 - 27 = 58$).

Because of variations in equipment and topography between the mining site and the dwelling site, and atmospheric conditions, the attenuation formula is considered accurate to no more than +/- 2 dBA. Therefore, staff finds the resultant noise level at the school due to proposed processing and stockpiling activity to be between 63 to 59 dBA. Similarly, staff finds the resultant noise level at the closest dwelling to be between 60 to 56 dBA.

Noise generated at this mining site is required to meet the standards found in Table 7 of OAR 340-35-035, for existing industrial sources of noise. This table sets forth the L50, L10, and L1 noise levels between the hours of 7 a.m. and 10 p.m. to be 55 dBA, 60 dBA, and 75 dBA, respectively. (L50, L10, and L1 refer to the level of noise that is expected to occur during 50%, 10%, and 1% in any given hour, or 30 minutes, 6 minutes, or 36 seconds, respectively.)

Due to the type of equipment and the duration of particular phases of activity during mining, the county considers the L10 noise level for medium duration noises to be the appropriate standard to use for evaluating mining operations. The L10 standard is 60 dBA, based on the above-mentioned Table 7. As indicated above, noise can be expected to reach a level of up to 63 dBA at the school and 60 dBA at the dwelling, exceeding the 60 dBA standard. However, these values do not account for mature trees between the operations area and the noise-sensitive uses, or the fact that the crusher would be located approximately 25 feet below grade. Given these additional factors, staff finds that expected noise levels at both the school and dwelling would meet the 60 dBA standard.

I. Hours of Operation.

1. Mineral and aggregate extraction, processing and equipment operation is limited to the following operating hours:

- a. **Surface mining sites located within one-half mile of any noise-sensitive use or structure existing on the effective date of Ordinance No. 90-014: 7:00 a.m. to 6:00 p.m. - Monday through Friday and 8:00 a.m. to 5:00 p.m. - Saturday.**
- b. **All other sites: 7:00 a.m. to 10:00 p.m. - Monday through Saturday.**
- c. **No surface mining operations shall be conducted on Sundays or the following legal holidays: New Year's Day, Memorial Day, July 4th, Labor Day, Thanksgiving Day, Christmas Day.**

FINDING: The proposed processing and stockpiling activity would be located within one-half mile of noise-sensitive uses (dwellings and school), as specified in foregoing findings. The proposed hours of operation would be 7:00 a.m. to 5:00 p.m., Monday through Friday. This would comply with criterion 'a' above. The applicant's burden of proof indicates no surface mining operations would be conducted on Saturdays, Sundays or the legal holidays listed above. Compliance with the specified operating hours has been added as a condition of approval.

J. Drilling and Blasting.

1. **Drilling and blasting are allowed under the site-specific ESEE analysis in the surface mining element of the Comprehensive Plan.**
2. **Drilling and blasting which are to be conducted within one-half mile of any noise-sensitive or dust-sensitive use or structure or agricultural use involving the raising of animals meet or can meet the following standards:**
 - a. **DEQ noise standards for drilling and blasting.**
 - b. **A plan addressing the potential for flying rocks and other effects on surrounding uses has been submitted to and approved by the County.**
 - c. **Blasting shall be restricted to the hours of 9:00 a.m. to 5:00 p.m., Monday through Friday, and no blasting will occur on Saturdays, Sundays or legal holidays identified in DCC 18.52.110(I)(2).**
 - d. **A plan has been submitted to and approved by the County describing how the operator will notify the owners and inhabitants of the protected uses identified in DCC 18.52.110(J)(2), which are located within one-half mile of the blasting site of proposed blasting written notice:**
 - i. **Delivered in a manner calculated to be received by each person entitled to notice at least 48 hours prior to the time the blasting activity will occur;**
 - ii. **Containing a statement providing that the recipient property owner must provide the notice to tenants and inhabitants on the subject property.**
 - iii. **In the case of ongoing blasting, given at least once each month and specifying the days and hours that blasting will occur; and**
 - iv. **Retained by the operator, along with a list of persons notified, for at least one year after blasting occurs.**

FINDING: The applicant is proposing drilling and blasting as part of this application. The DEQ standards for noise must be met by the contractor hired by the applicant for the drilling and blasting. The applicant has stated that the contractor for the crushing is required to submit a plan for earth movement, flying rocks or other effects on surrounding uses. ~~Drilling and blasting~~ Blasting would be limited to the hours of 9:00 a.m. to 5:00 p.m., Monday through Friday, as outlined above. The applicant would be required to send the notice specified under item 'd' above, and keep records for at least one year after the blasting occurs. These would be made conditions of approval.

L. Fish and Wildlife Protection.

1. **Fish and wildlife values and habitat required by the site specific ESEE analysis to be conserved and protected are conserved and protected by use of methods including, but not limited to: Seasonal operations and access road closures; retention of or creation of vegetative cover and riparian habitat; and erection of fencing or other barriers to protect wildlife from steep extraction site slopes.**
2. **Mitigation, as defined in this title, will be provided to compensate for any loss of fish and wildlife habitat caused by the surface mining activity which habitat is required to be protected by the site-specific ESEE analysis. When mitigation is provided, the type and**

effectiveness of mitigation required has been determined by the Planning Director or Hearings Body to be appropriate from available evidence and in consultation with the Oregon Department of Fish and Wildlife.

FINDING: The subject property has no identified fish and wildlife values or habitat in the County comprehensive plan. No mitigation is required.

M. *Surface water management is provided in a manner which meets all applicable DEQ water quality standards and DOGAMI requirements, and which demonstrates that all water necessary for the proposed operation of the surface mine, including dust control, landscaping and processing of material, has been appropriated to the surface mining site and is legally available for such use. The applicant must provide written documentation of any water rights from the respective water district and Oregon Watermaster's office prior to any mining of the site.*

FINDING: The applicant states that surface water management for the mining site falls within the surface water management requirements of the Solid Waste Department's DEQ disposal permit. According to the applicant, water is provided on the site by Avion Water Company, and this water can be used for dust control, landscaping or processing of the material.

N. *Storage of equipment, structures and other materials at the site is limited to that which is necessary and appurtenant to the mining operation or other uses permitted on the site.*

FINDING: The applicant states that only mining-related equipment would be stored at the site for the crushing and storage of the material.

O. *A security plan for the subject site has been submitted and approved by the county and, where appropriate, by DOGAMI which addresses the following issues:*

- 1. lighting;***
- 2. fencing;***
- 3. gates at access points;***
- 4. water impoundments;***
- 5. sloping; and***
- 6. security of vehicles and equipment***

FINDING: The applicant states that all proposed operations would take place in the landfill compound, which is enclosed with a 6-foot-tall chain link fence, and which has gates at access points that are locked during non-business hours. The only lighting on the site is exterior lights on existing buildings. Staff finds that the site would meet this criterion.

P. *All impacts of the mining activities identified in the ESEE analysis for the specific site are addressed and have been resolved at the time of site plan approval or before the start of mining activity.*

FINDING: The specific requirements established in the "Program to Meet the Goal" section of the ESEE analysis (pages 8, 9) for SM Site no. 390 are as follows:

- a. *Setbacks shall be required for potential conflicting residential and other development;*
- b. *Noise and visual impacts shall be mitigated by buffering and screening;*
- c. *Processing operations and equipment shall be placed at a location on the site that will permit such activity to operate within DEQ noise and dust requirements;*
- d. *Use of vehicles in the extraction, processing, and transportation of the material shall meet the DEQ noise level requirements.*

The Board finds that processing on the site will be allowed.

Previous findings detail how each of the above-referenced criteria would be met.

6. Section 18.52.140. Conditional use criteria.

The criteria set forth in this section shall be the only conditional use criteria applicable to the surface mining activities described below. Compliance with these criteria shall be demonstrated at the time of site plan review.

- A. *Crushing. When a site has been designated for crushing of mineral and aggregate materials under the site-specific ESEE analysis in the surface mining element of the Comprehensive Plan, the following conditions apply:***
- 1. *If a crusher is to be located less than one-half mile from a noise-sensitive use or structure existing on the effective date of Ordinance 90-014, the applicant shall demonstrate through a noise report from a qualified, registered sound engineer or similarly qualified professional, that the crusher can meet all applicable DEQ industrial and commercial noise control standards as designed and located, or by methods including, but not limited to: Modification or muffling of the crusher; placement of the crusher below grade or behind berms.***
 - 2. *If a crusher is to remain on the site for longer than 60 days in any 18-month period, the applicant shall demonstrate that it will be screened in accordance with DCC 18.52.110(B).***

FINDING: The proposed crusher would be located a minimum of 1,500 feet from the closest noise-sensitive use, which is a dwelling identified on Assessor map 18-12-15, as tax lot 400. A noise analysis was made by staff in a foregoing finding and the operation was determined to meet DEQ noise standards taking into consideration intervening mature trees and the location of the crusher approximately 25 feet below grade. It is anticipated that the crusher may be on-site for longer than 60 days in any 18-month period. With the existing screening from topography, fencing, retaining wall and landscaping, staff finds that the crusher would be screened according to section 18.52.110(B).

IV. CONCLUSION:

Staff finds the applicant can meet all of the required approval criteria. The conditional use permit and site plan review are **APPROVED**, subject to the conditions of approval listed below.

V. RECOMMENDED CONDITIONS OF APPROVAL:

1. This approval is based upon the site plan and information submitted by the applicant. Any substantial change in the approved plan would require a new application.
2. The applicant shall follow and meet all requirements of the site-specific ESEE analysis.
3. Any dust and noise created from the mining operation and associated activities at this site shall be controlled so as to meet applicable DEQ standards, and in such a manner as not to be a nuisance as defined in OAR 340-21-050. Watering or chemical treatment of the roads on the site used for access shall be required where deemed necessary to prevent a nuisance. The access roads shall be maintained for safety.
4. All mining operations shall be conducted between the hours of 7:00 a.m. and 5:00 p.m., Monday through Friday. No surface mining operations shall be conducted on Saturdays, Sundays or the following legal holidays: New Year's Day, Memorial Day, July 4th, Labor Day, Thanksgiving Day, Christmas Day.
5. ~~Drilling and blasting~~ Blasting to excavate the materials shall only be allowed between the hours of 9:00 a.m. to 5:00 p.m., Monday through Friday. The applicant shall send the required notice under section 18.52.110(J)(2)(d) for the drilling and blasting.
6. Any exterior lighting used for the surface mining operation shall meet all requirements of Chapter 15.10, Outdoor Lighting, of the Deschutes County Code.
7. The applicant (or contractor) shall obtain an Air Contaminate Discharge Permit from the Oregon Department of Environmental Quality, and submit a copy to the Planning Division, prior to commencement of any crushing on the site. The rock crusher shall be located below natural ground level to reduce the amount of noise generated from the site, as specified on the submitted plan.
8. The existing topographic and vegetative screening for the surface mine shall be maintained and/or replaced to assure screening throughout the duration of the crushing operation.
9. Only equipment, structures and materials related to proposed surface mining shall be allowed on the surface mining site. All surface mining equipment and related structures shall be removed from the site within 30 days of completion of all mining and reclamation.
10. No on-site sales of excavated or crushed material shall be allowed for the site.

VII. DURATION OF APPROVAL:

The applicant shall initiate the use within two (2) years following the date this decision becomes final or obtain an extension of time pursuant to Section 22.36.010 of the County Code, or this approval shall be void.

This decision becomes final twelve (12) days from the date of this mailing unless appealed by a party of interest.

DESCHUTES COUNTY PLANNING DIVISION



Written by: Anthony Ragaine, Senior Planner

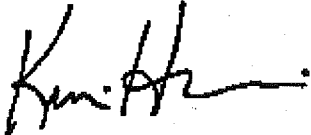

Reviewed by: Kevin M. Harrison, Acting Planning Director

Dated this 2nd day of October, 2008

Mailed this 2nd day of October, 2008

AJR/slb

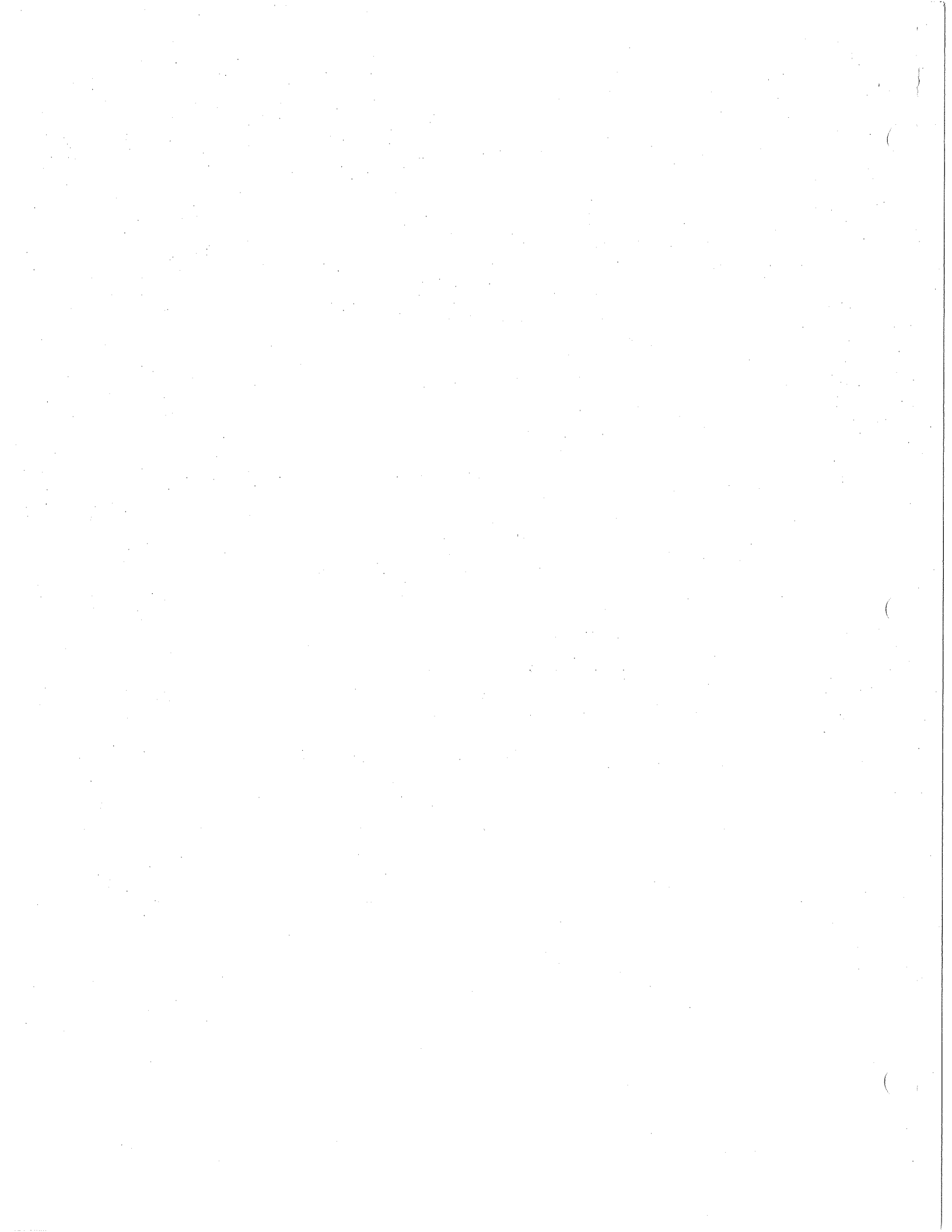



NOTICE OF DECISION

The Deschutes County Planning Division has approved the land use application(s) described below:

- FILE NUMBER:** 247-19-000220-CU, 222-SP
- APPLICANT:** Deschutes County Solid Waste Department
- OWNER:** Deschutes County
- LOCATION:** The subject property has an assigned address of 61150 SE 27th Street, Bend. It is identified on County Assessor's Map 18-12-14, as tax lot 100.
- PROPOSAL:** The applicant requests Conditional Use Permit and Site Plan Review approval to establish a soil stockpile area at Knott Landfill ("Landfill"). The 20-acre site will receive approximately 800,000 cubic yards of soil excavated from future disposal cells 8 and 9 of the Landfill. The soil will be deposited over a 3-5 month period, spread evenly to the edges of the defined stockpile site, with an approximate maximum height of 30 feet. The stockpile area will be enclosed by a 6-foot-high chain-link fence. Upon completion of the formal activity to deposit and spread the soil, the stockpiled material will be treated with Tortisshell HPPS-550, which forms an impermeable hard crust/cap to prevent any water or wind erosion.

When necessary to cap or close a disposal cell, the applicant anticipates removal of the stockpiled material will be accomplished over a period of 6 to 8 months. During removal activities, dust control methods such as application of water will be employed to prevent dust impacts. If a portion of the stockpile will remain in place between removal activities, the remaining stockpile will again be treated with Tortisshell HPPS-550. Once all stockpiled material is removed, the stockpile area will be reclaimed with native plants with the intent of minimizing dust and weed generation usually associated with disturbed land.

STAFF CONTACT: Anthony Raguine, Senior Planner
anthony.raguine@deschutes.org, (541) 617-4739

DOCUMENTS: Can be viewed and downloaded from:
www.buildingpermits.oregon.gov and <http://dial.deschutes.org>

APPLICABLE CRITERIA: The Planning Division reviewed this application for compliance against criteria contained in Chapters 18.16, 18.56, 18.116, 18.124 and 18.128 in Title 18 of the Deschutes County Code (DCC), the Deschutes County Zoning Ordinance, as well as against the procedural requirements of Title 22 of the DCC.

DECISION: Staff finds that the application meets applicable criteria, and approval is being granted subject to the following conditions:

CONDITIONS OF APPROVAL

- A. This approval is based upon the application, site plan, and supporting documentation submitted by the Applicant. Any substantial change in this approved use will require review through a new land use application.
- B. **Days and hours of operation for both stockpiling and removal activities** shall be limited to 7:00 am to 6:00 pm, Monday through Saturday.
- C. **During stockpiling and removal activities**, the applicant shall employ dust control methods including, but not limited to, application of water.
- D. **After the completion of stockpiling activities**, the applicant shall apply a hardening/capping agent to the excavated material to prevent water and wind erosion. The applicant shall maintain the hardening/capping agent for as long as the stockpiled material remains on-site.
- E. **If a portion of the stockpile will remain in place between removal activities**, the applicant shall apply a hardening/capping agent to the remaining stockpiled material to prevent water and wind erosion. The applicant shall maintain the hardening/capping agent for as long as the stockpiled material remains on-site.
- F. **At all times**, the height of the stockpiled material shall not exceed 30 feet.
- G. **At all times**, all drainage retention facilities associated with the stockpile site shall be designed such that surface water is directed away from private property lines.
- H. **For as long as the stockpile site remains on-site**, the applicant shall preserve existing mature trees between the stockpile site and private property lines. This condition does not prohibit maintenance of existing trees, or the removal of dead, diseased or hazardous trees.

- I. **After all stockpiled material is removed**, the applicant shall apply a native hydroseed mix to the stockpile site.

This decision becomes final twelve (12) days after the date mailed, unless appealed by a party of interest. To appeal, it is necessary to submit a Notice of Appeal, the appeal fee of \$250.00 and a statement raising any issue relied upon for appeal with sufficient specificity to afford the Hearings Body an adequate opportunity to respond to and resolve each issue.

Copies of the application, all documents and evidence submitted by or on behalf of the applicant and applicable criteria are available for inspection at no cost. Copies can be purchased for 25 cents per page.

NOTICE TO MORTGAGEE, LIEN HOLDER, VENDOR OR SELLER: ORS CHAPTER 215 REQUIRES THAT IF YOU RECEIVE THIS NOTICE, IT MUST BE PROMPTLY FORWARDED TO THE PURCHASER.

This Notice was mailed pursuant to Deschutes County Code Chapter 22.24.

Full Size Sheet Format is 11x17. If Printed Sheet Size Not 11x17, Then This Sheet Format has Been Modified & Indicated Drawing Scale is Not Accurate.

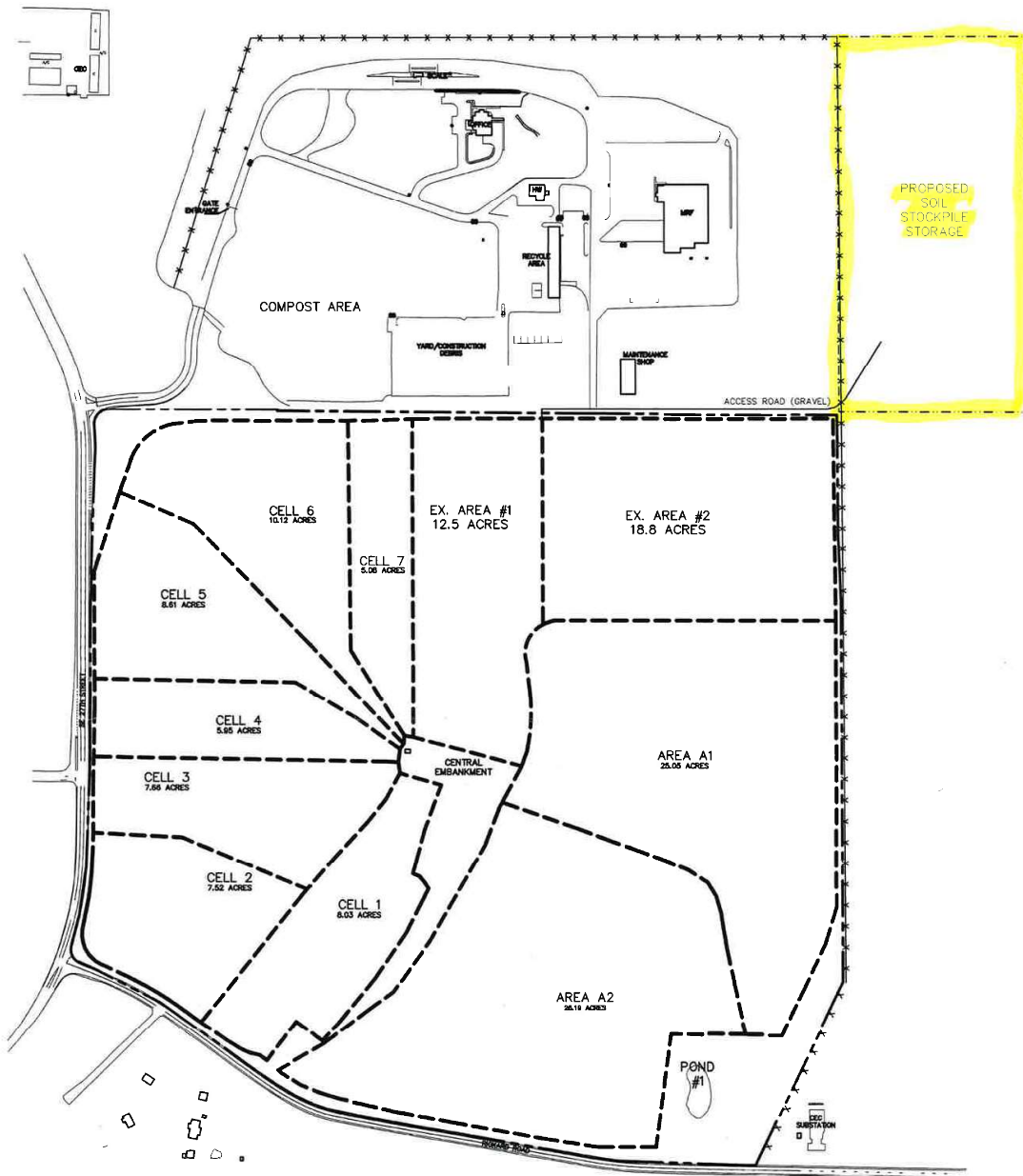

LEGEND	
	CELL BOUNDARY
	PROPERTY LINE
	NEW FENCE
	EXISTING FENCE

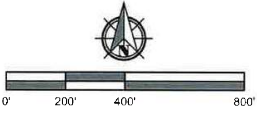

PREPARED FOR: DESCHUTES COUNTY DEPARTMENT OF SOLID WASTE

A	PROPOSED SOIL STOCKPILE STORAGE AREA KNOTT LANDFILL BEND, OREGON		PBS Engineering and Environmental Inc. 390 NE Emerson Avenue, #201 Bend, OR 97701 541.388.9290 pbsusa.com
PROJECT	DATE	SHEET ID	
80429.010	JAN 2019	A	

PART IX
CONTRACT DRAWINGS
(Bound Separately)

PART X
STANDARD DRAWINGS

20-JUL-2020

RD815.dgn

TYPE CL-6

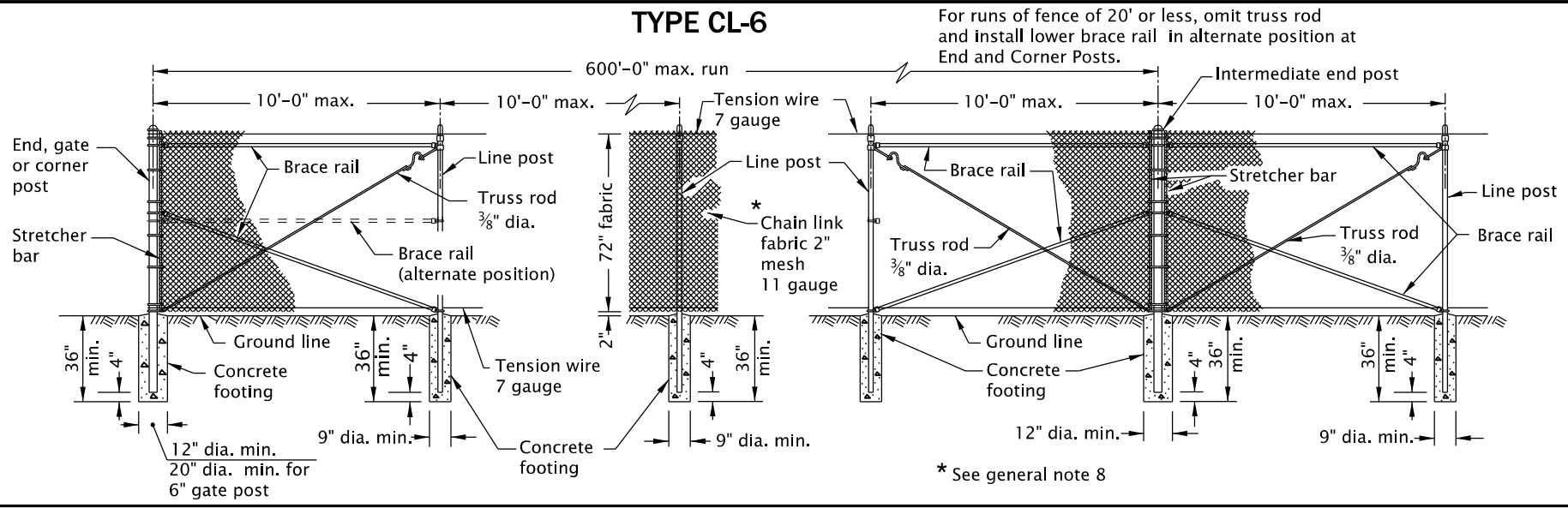

TYPE CL-6R

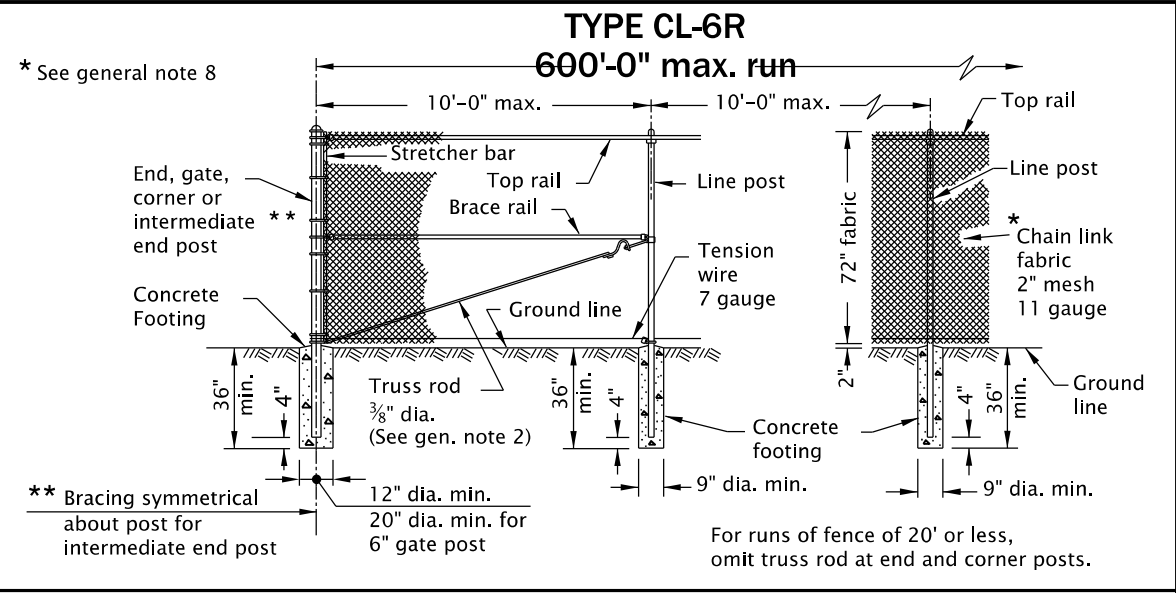

TYPES CL-4 & CL-5

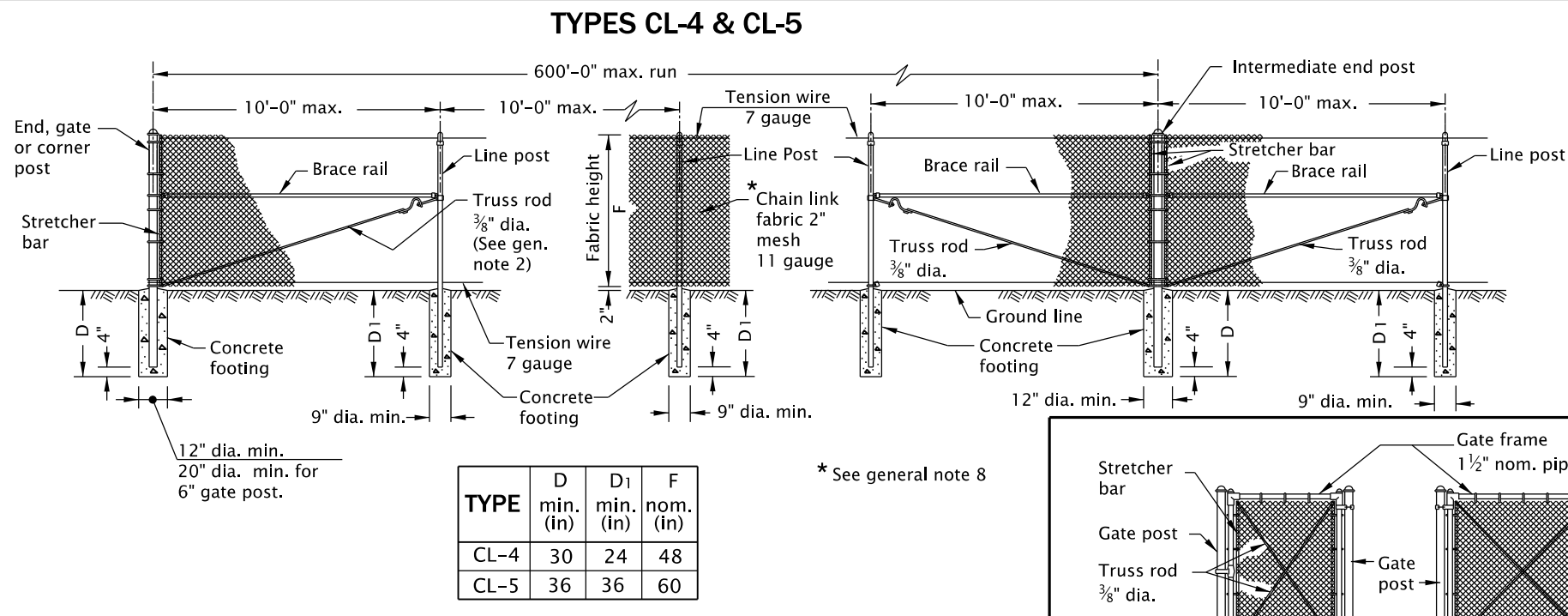

TYPE	D min. (in)	D1 min. (in)	F nom. (in)
CL-4	30	24	48
CL-5	36	36	60

TYPES CL-4R & CL-5R

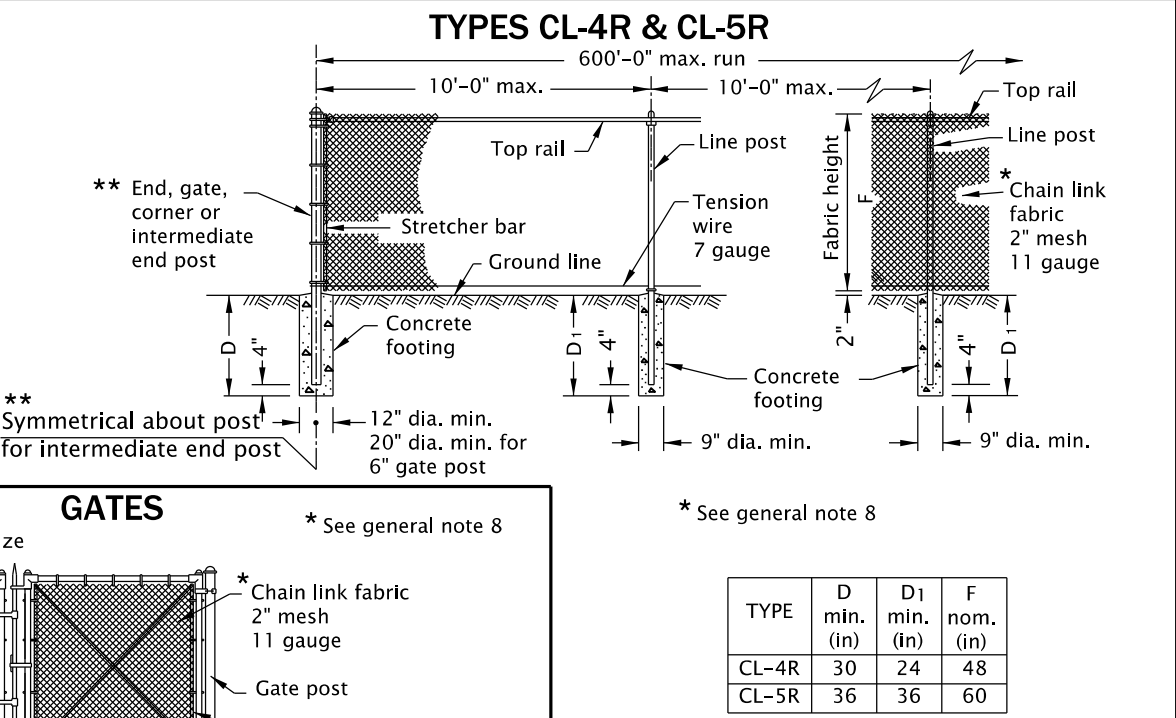

TYPE	D min. (in)	D1 min. (in)	F nom. (in)
CL-4R	30	24	48
CL-5R	36	36	60

GATES

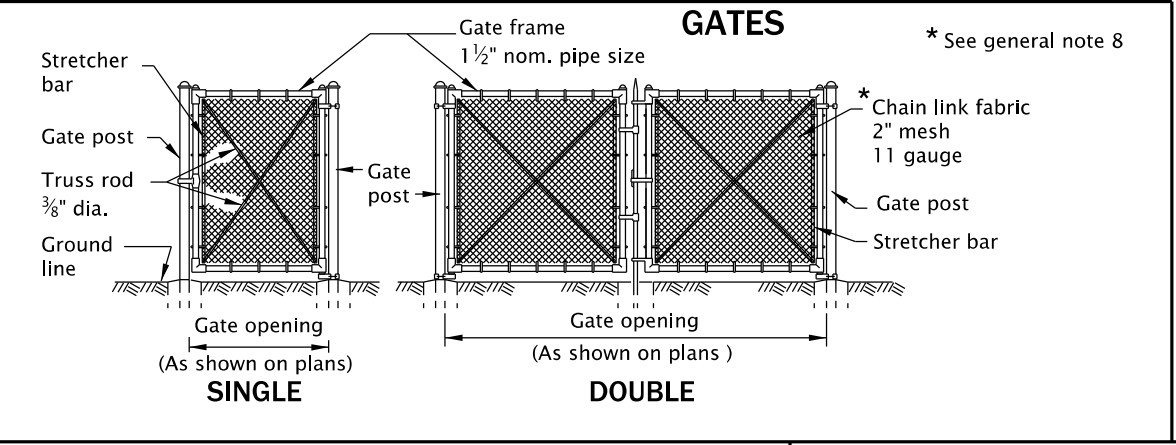

TABLE 1

TYPE	MEMBER														
	BRACE AND TOP RAILS		LINE POSTS				END, CORNER & INTERMEDIATE END POST		GATE OPENING (ft)		GATE POSTS				
	TUBULAR		TUBULAR	H-SECTION		TUBULAR		SINGLE GATE	DOUBLE GATE	Fence Industry (in)	Norm. Dia. (in)				
CL-4 & CL-4R CL-5 & CL-5R	Fence Industry (in)	1 5/8	1 1/4	Fence Industry (in)	1 7/8	1 1/2	1 7/8 x 1 5/8	2.72	Fence Industry (in)	2 3/8	2	Up thru 6	Up thru 12	2 7/8	2 1/2
CL-6 & CL-6R	Fence Industry (in)	1 5/8	1 1/4	Fence Industry (in)	2 3/8	2	2 1/4 x 2	4.10	Fence Industry (in)	2 7/8	2 1/2	7 thru 13	13 thru 26	4	3 1/2
												14 thru 18	27 thru 36	6 5/8	6

NOTE: For CL-6, CL-6R, CL-8, CL-8R, CL-10 & CL-10R, the hardware is minimum and does not include slat wind loading.

GENERAL NOTES FOR ALL DETAILS ON THIS SHEET:

- Do not use top rail where fence can be struck by an errant vehicle.
- Fittings shown are illustrative of use and not specific as to design.
- Gate posts on each side of a gate opening to be the same size. At a double gate installation with unequal width gates, size of both posts to be as indicated for a single gate installation of the wider gate width.
- For cross sectional dimensions of members, see Table 1.
- Posts and rails with sections not shown that meet the requirements of AASHTO M181 are acceptable alternates. See ODOT's QPL for acceptable alternates.
- All concrete shall be commercial grade concrete.
- All chain link fabric top and bottom selvage shall be knuckled finish.
- Chain link fabric for the fence to be installed with pickets shall be 9 gauge wire woven in 3 1/2" by 5 1/2" diamond mesh.
- See project plans for details not shown.
- Add fence grounding as required.

The selection and use of this Standard Drawing, while designed in accordance with generally accepted engineering principles and practices, is the sole responsibility of the user and should not be used without first consulting a Registered Professional Engineer.

All materials shall be in accordance with the current Oregon Standard Specifications.

OREGON STANDARD DRAWINGS

CHAIN LINK FENCE

2024

DATE	REVISION	DESCRIPTION

CALC. BOOK NO. ---	N/A ---	SDR DATE-- 13-JAN-2020	RD815
--------------------	---------	------------------------	--------------

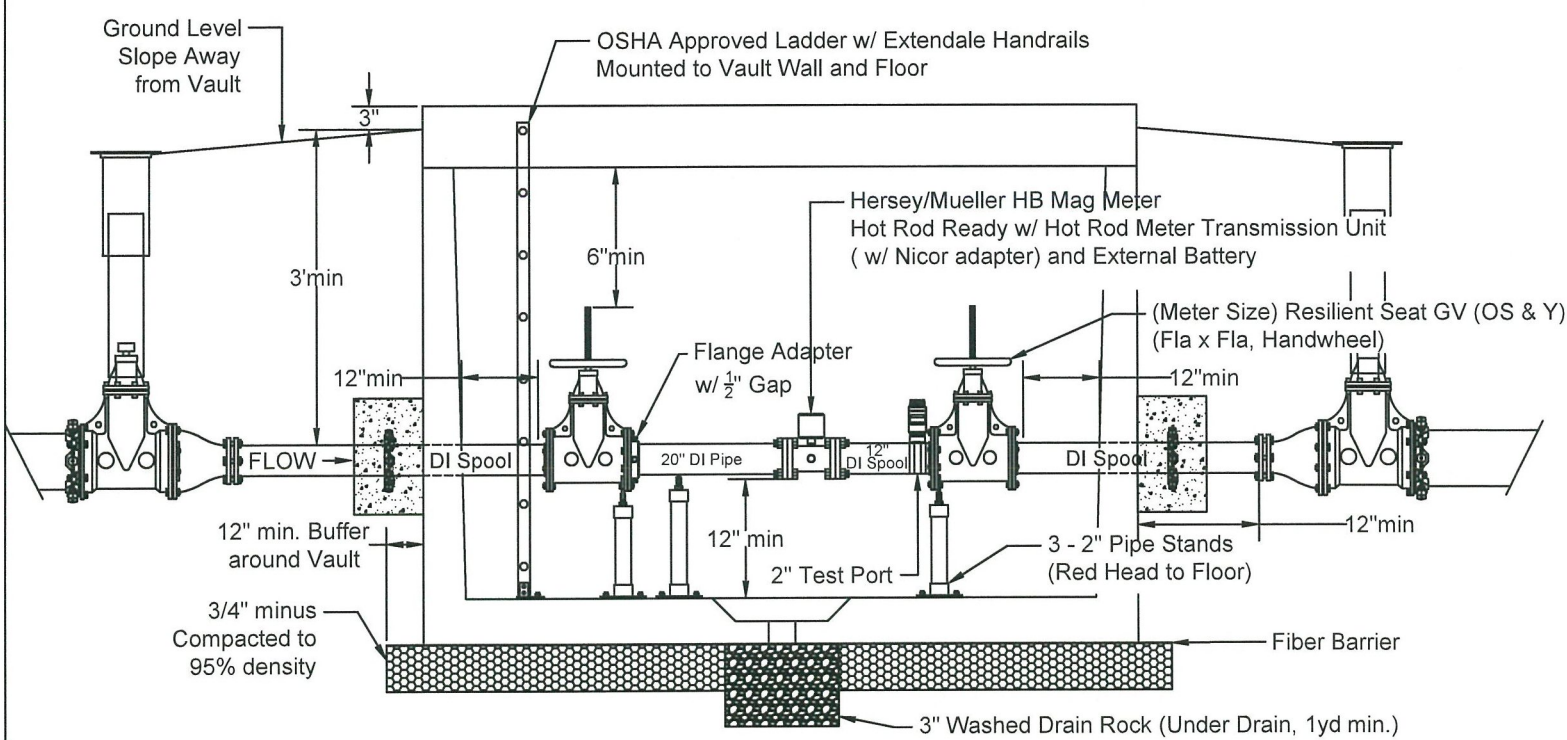
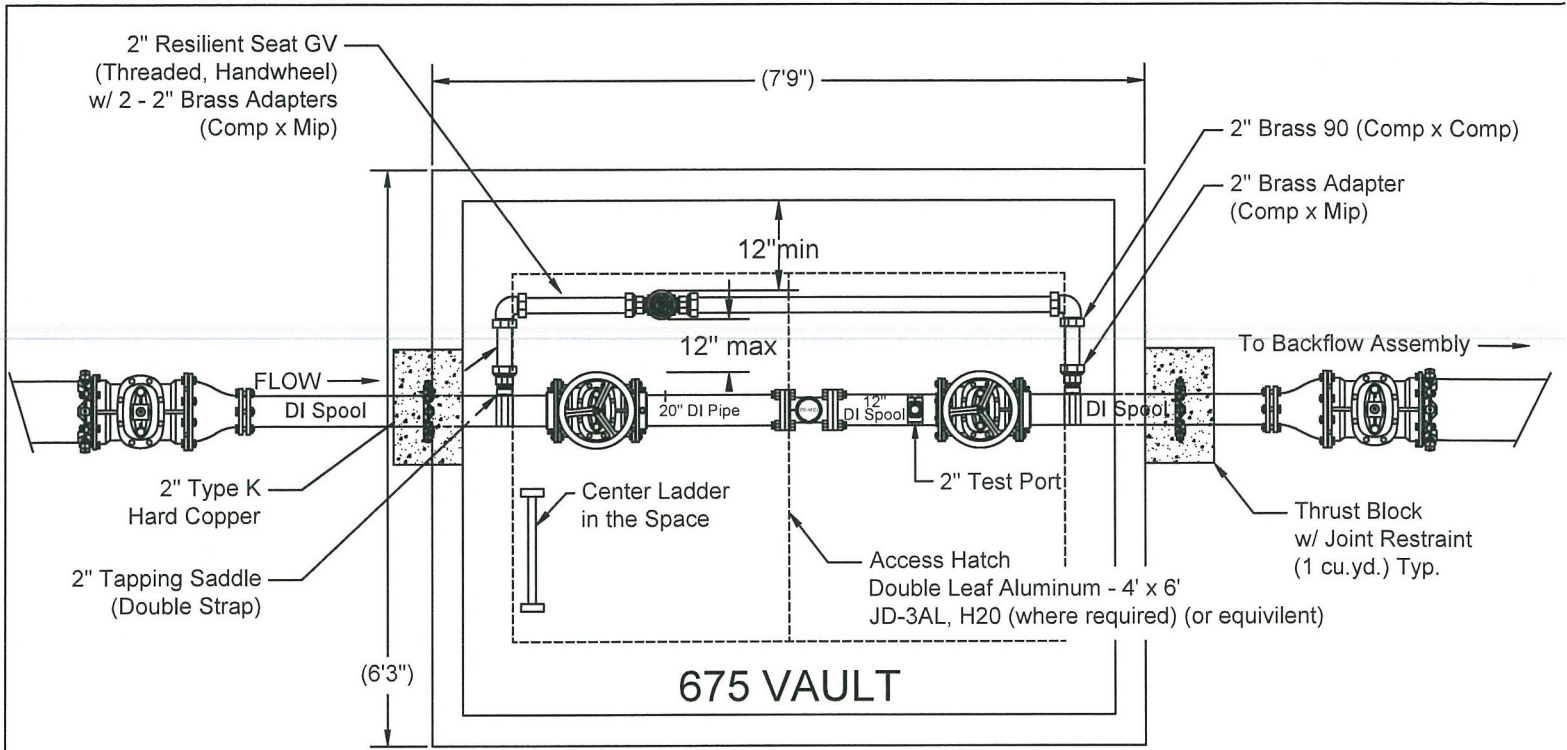

- NOTES:
1. Seal all openings in the vault with non-shrink grout, or Link-Seal.
 2. 2 - 1 cu.yd. thrust blocks outside vault, w/ pipe clamp type Joint Restraints, entering and exiting the vault.
 3. The meter size shall match the service size, or one size smaller.
 4. A 2" test port shall be installed, vertically, with a 2" double strap tapping saddle, and a 2" Corp Stop (fip x fip w/ brass cap). The test port must be as close to the downstream GV as possible.
 5. Full mainline size GV's shall be set outside of the vault. You will need to reduce from full mainline size to the meter size, and use DI Spools entering the vault from the reducers. ALL REDUCERS MUST BE OUTSIDE OF VAULT
 6. The meter must have no fittings within a length of 5 times the diameter of the pipe, upstream, and 3 times the diameter of the pipe, downstream. With the exception of the test port.

DWN BY: TEL	Avion design specifications do not relieve the developer, engineer, or contractor from responsibility to design and construct the water system in accordance with good engineering and construction practices. Must adhere to OAR 333-061-0050 Construction Standards.	AVION WATER CO 60813 PARRELL RD BEND, OR 97702	NOT TO SCALE	
DATE: November 2022			REV/DATE	REV/DATE
BEND, OREGON		3" & 4" METER INSTALLATION	CITY OF BEND	
			2" & LARGER DOUBLE CHECK VALVE ASSEMBLY	

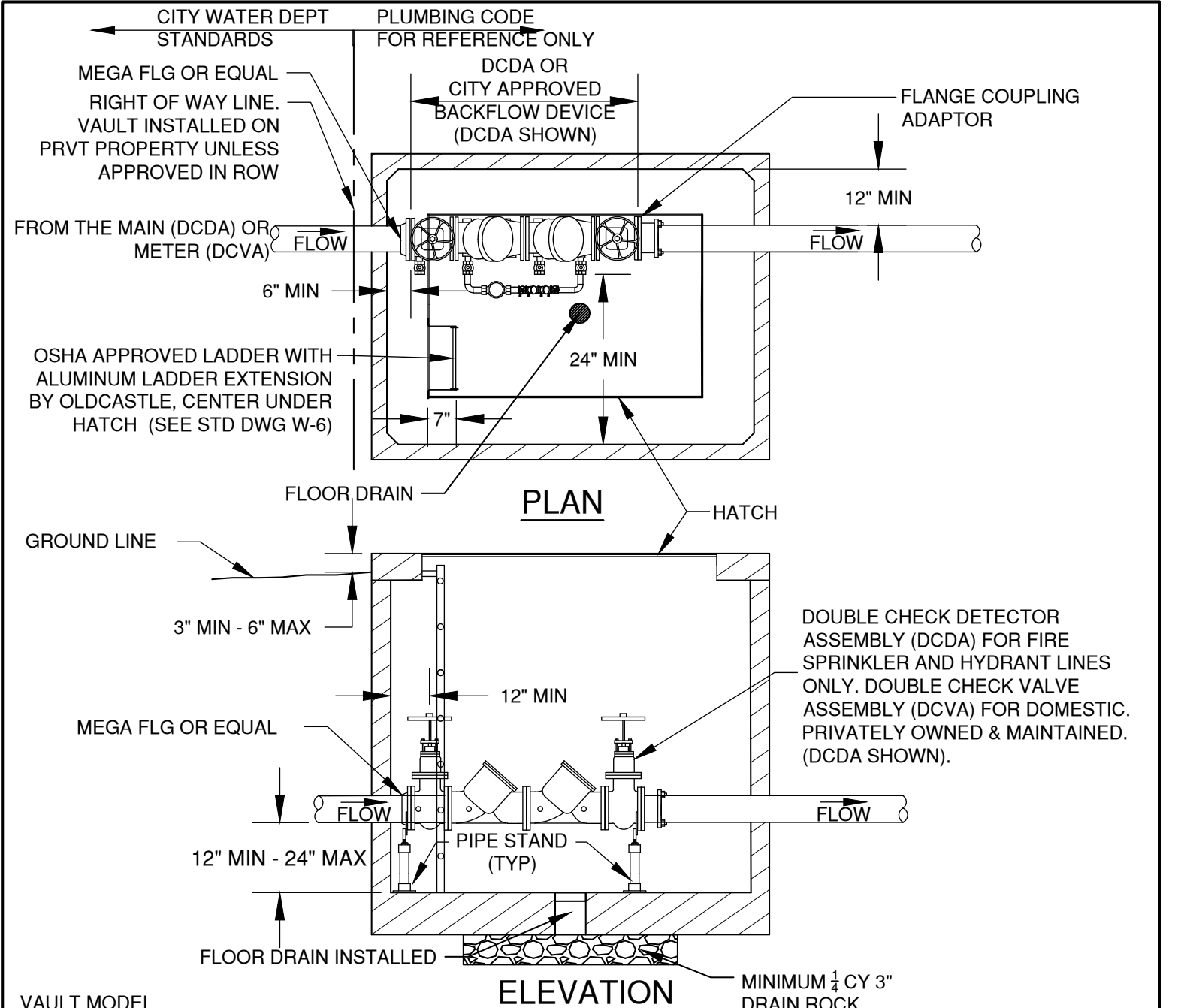

VAULT MODEL

PIPE SIZE	UTILITY VAULT OR EQUAL		BILCO DOOR OR EQUAL
	W/ FDC*	W/O FDC	
3		660-WA	J-5AL
4	676-WA	577-WA	J-5AL
6	687-WA	676-WA	J-5AL
8	5106-LA	687-WA	JD-3AL
10	5106-LA	5106-LA	JD-3AL

- NOTES:
1. ENGINEER TO PROVIDE RESTRAIN DETAIL FOR ALL PIPE ENTERING & EXITING VAULT
 2. CONTRACTOR TO SEAL ALL OPENINGS IN VAULT WITH NON-SHRINK GROUT PRIOR TO BACKFILLING
 3. CONDUIT BROUGHT TO VAULT FOR PUMP POWER AND DETECTOR WIRING.
 4. ENGINEERED DESIGN TO BE PROVIDED WITH PERMIT.
 5. VAULT AND LID TO BE TRAFFIC RATED
 6. ALL FIRE LINES SHALL HAVE THE VAULT & DOUBLE CHECK DETECTOR ASSEMBLY (DCDA) INSTALLED CONCURRENTLY FOR TESTING & DISINFECTION TO THE CITY MAIN.
 7. PIPE SHALL MEET CITY ROW SPECIFICATIONS FROM MAIN TO DCDA

* FOR FIRE SPRINKLER VAULTS, REFER TO W-13B. FIRE SPRINKLER VAULTS INSTALLED IN RIGHT OF WAY OR UTILITY EASEMENT ONLY WHEN APPROVED BY CITY ENGINEER.

DRAWN: AJD	CITY OF BEND	CITY OF BEND STANDARD DRAWING 710 NW WALL ST., BEND, OREGON 97701	SCALE: NTS
DIV: WATER			DATE: 01/31/2022
REV: DATE			APPR: