



Establishment ID: _____
Owner ID: _____
For office use only

**FOOD SERVICE
LICENSE APPLICATION**

MOBILE UNIT, COMMISSARY, WAREHOUSE, VENDING MACHINE

Mobile Unit Commissary Warehouse Vending Machine
 Class: _____ # Units: _____
 New Construction Remodel
 Change of Ownership Former establishment name: _____

Establishment Name: _____
 Establishment Physical Address: _____
 Establishment Billing Address: _____
 Establishment Phone #: _____

Owner/Applicant Name: _____
 Individual Corporation Partnership Other: _____

Do you own other establishments licensed by the Health Dept.? No Yes
 Name(s): _____

Owner Physical Address: _____
 Owner Billing Address: _____
 Owner Phone #: _____ Owner Cell #: _____
 Owner Fax #: _____ Owner E-mail: _____

The payment of \$ _____ license fee is hereby made for application to operate the above establishment in compliance with all applicable food service regulations. I understand that failure to meet the requirements of the provisions of Oregon Revised Statutes, Chapter 624, and the Administrative Rules, Chapter 333, of the Oregon Health Authority may require denial or revocation of the license. Furthermore, I attest that the information provided on this form is accurate.

Signature of Applicant: _____ Date: _____

Mail application and check payable to your local Environmental Health Office at:

FOR OFFICE USE ONLY	
Fee received: _____	Date: _____
<input type="checkbox"/> Cash <input type="checkbox"/> Check# _____ <input type="checkbox"/> Money Order	
Inspected by: _____	Date: _____
<input type="checkbox"/> Approved <input type="checkbox"/> Not Approved	

MOBILE FOOD UNIT APPLICATION PACKET

Please submit the following documentation with your application along with the appropriate fees to Deschutes County Environmental Health. **Approval must be obtained prior to construction or operation of your unit.**

THIS APPLICATION EXPIRES ONE YEAR FROM DATE OF APPROVAL

- Mobile Unit Plan Review Application Form
- Complete Menu: A printed menu or list of all food you will serve
- Floor Plan/Equipment Layout
 - Complete plans of the unit drawn to scale, including floor plan, equipment location, and plumbing fixtures. Does not have to be professionally done.
 - Handwashing sink
 - Three-compartment sink/drain boards (if applicable)
 - Indirect drain (air gap) for three-compartment sink
 - Food preparation sink (if applicable)
 - All equipment in unit, including, but not limited to: (a) Type/model of refrigeration and freezer equipment, (b) Cooking equipment, (c) Hood vent, etc.
 - Fresh water tank
 - Wastewater tank
- Food Handling Procedures
- Three-Compartment Sink Dimensions
- Fresh Water Tank Dimensions
- Wastewater Tank Dimensions
- Operating Location/Schedule (if known)
- Restroom Agreement Form
- Commissary/Warehouse usage agreement form (if needed)
- Cooling Plan and Logs (if needed)

General Requirements and Limitations

Mobile Unit: A mobile food unit is defined in OAR 333-150-0000, 1-201.10 as "*...any vehicle that is self-propelled or that can be pulled or pushed down a sidewalk, street, highway or waterway, on which food is prepared, processed or converted or which is used in selling and dispensing food to the ultimate consumer.*"

Classifications: There are four types of mobile food units. The mobile food unit classifications are based upon the type of **menu served**. Failure to obtain approval for a menu change after it has initially been approved may result in closure of your unit.

CLASS I - These units can serve only intact, packaged foods and non-potentially hazardous drinks. No preparation or assembly of foods or beverages may take place on the unit. Non-potentially hazardous beverages must be provided from covered urns or dispenser heads only. No dispensed ice is allowed.

CLASS II - These units may dispense unpackaged foods. However, no cooking, preparation or assembly of foods is allowed on the unit. No self-service by customers is allowed.

CLASS III - These units may cook, prepare and assemble food items. However, cooking of raw animal foods on the unit is not allowed.

CLASS IV - These units may serve a full menu.

Maintained as Approved: Mobile food units must be maintained and operated as originally designed and approved. Units that have been modified without approval must revert to the approved design and operation. OAR 333-162-0020

Wheels: Mobile food units must remain mobile at all times. The wheels of a mobile food unit must be functional and appropriate for the type of unit and may not be removed at the operating location. OAR 333-162-0030

Designed in One Piece: Mobile food units must be designed and constructed to move as a single piece. Mobile food units may not be designed to be assembled at the operating location. See OAR 333-162-0020 for exceptions.

Integral: All operations and equipment must be integral to the mobile food unit. Integral means rigidly and physically attached to the unit without restricting the mobility of the unit while in transit. The following exceptions are allowed:

Auxiliary Storage: A mobile unit may provide auxiliary storage outside the unit to support daily operations if:

- Items are limited to what is necessary for that day's operation.
- At the end of the workday, auxiliary storage must be placed in the unit, in a licensed warehouse, or at a licensed commissary.
- No self-service, assembly or preparation activities may occur from auxiliary storage containers.
- Refrigerators and freezers may not be placed outside the mobile food unit for use as auxiliary storage and must be located in the unit, in a licensed warehouse or at a licensed commissary.

Shelves and Tables: Mobile food units may use small folding shelves or tables that are integral to the unit to display non-potentially hazardous condiments and customer single-use articles such as napkins and plastic utensils. OAR 333-162-0020

Non-PHF Display: Mobile food units may display commercially packaged, non-potentially hazardous food items, such as cans of soda or bags of chips, off the unit if limited to what can be served or sold during a typical meal period. OAR 333-162-0020

Cooking Units: Class IV mobile food units may use one cooking unit, such as a BBQ or pizza oven, that is not integral to the unit. The cooking unit may not be a flat top grill, griddle, wok, steamtable, stovetop, oven or similar cooking device. The cooking unit must be able to move with the unit. OAR 333-162-0020

Exterior Protection: Mobile food units must be secured and protected from contamination when not in operation. OAR 333-162-0680

Water and Sewer Capacity: Mobile food units must be designed with integral water and sewer tanks on the unit. A mobile food unit may connect to water and sewer if it is available at the operating location, however tanks must always remain on the unit. A unit cannot connect directly to fresh water without a direct connection to sewer as well. OAR 333-150-0000, Section 5-305.11

Restroom Distance: If a unit is parked in the same location for more than two hours, a restroom must be provided that is located within 500 feet of the unit. OAR 333-150-0000, Section 6-402.11

Seating: Mobile food unit operators may provide seating for customers if a readily accessible restroom and sufficient refuse containers with lids or covers are provided. OAR 333-162-0020

Warehouse: A warehouse may be used for storage of only **unopened packaged foods**, single service articles, utensils and equipment. Activities such as handling of unpackaged food, dishwashing and ice making are prohibited in a warehouse. OAR 333-162-0940

Commissary: A commissary is a place in which food, beverage, ingredients, containers, or supplies are kept, handled, packaged, prepped, or stored.

A mobile food unit may **not** serve as a commissary for another mobile food unit or as the base of operation for a caterer. OAR 333-162-0040

A newly licensed Class IV mobile food unit is required to operate from a licensed commissary.

Catering and Delivery: A mobile food unit may not provide catering services unless:

- 1) The unit operates from a licensed commissary that's capable of handling the menu; or
- 2) The unit has commercial-grade refrigeration equipment, has obtained a variance from the Oregon Health Authority, and uses only single-use articles for service to customers. OAR 333-162-0030

Indirect Drain (Air Gap): Required if 3 compartment sink is present. May be placed at single basin (sanitizer) or include all 3 basins, to prevent waste water from backing up into sink.

Air gap.

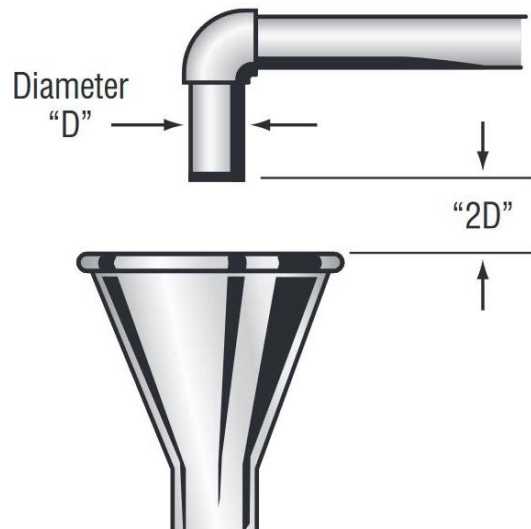

Finally, while this document contains some detailed information about the rules for the construction and operation of mobile food units, it does not contain all the requirements for your unit. Please refer to the Food Sanitation Rules www.healthoregon.org/foodsafety.

Requirements	Class I	Class II	Class III	Class IV
Water Supply Required	No	Yes	Yes	Yes
Handwashing System Required	No	Yes ¹	Yes ¹	Yes ¹
Dishwashing Sinks Required	No	No ²	Yes – Or Licensed Commissary ²	Yes ²
Assembly or Preparation Allowed	No	No	Yes	Yes
Cooking Allowed	No	No	Yes ³	Yes
Off-Unit Cooking Operation Allowed	No	No	No	Yes
Restroom Required	Yes	Yes	Yes	Yes
Examples	Prepackaged Sandwiches/ Dispensed Soda	Service of Unpackaged Food Items	Espresso/ Hot Dogs	No Menu Limitation

¹The handwashing system must be plumbed to provide hot and cold running water and a minimum of 5 gallons of water must be dedicated for handwashing.

²Must provide a minimum of 30 gallons of water for dishwashing or twice the volume of the three compartment sinks, if provided. Handwash sink and 3 compartment sink fresh water may be combined in one tank.

³May only cook foods that are not potentially hazardous when raw (rice, pasta, etc.). Animal foods must be pre-cooked.

***FLOOR PLAN LAYOUT EXAMPLE:**

(Scale – ¼” = 1’)

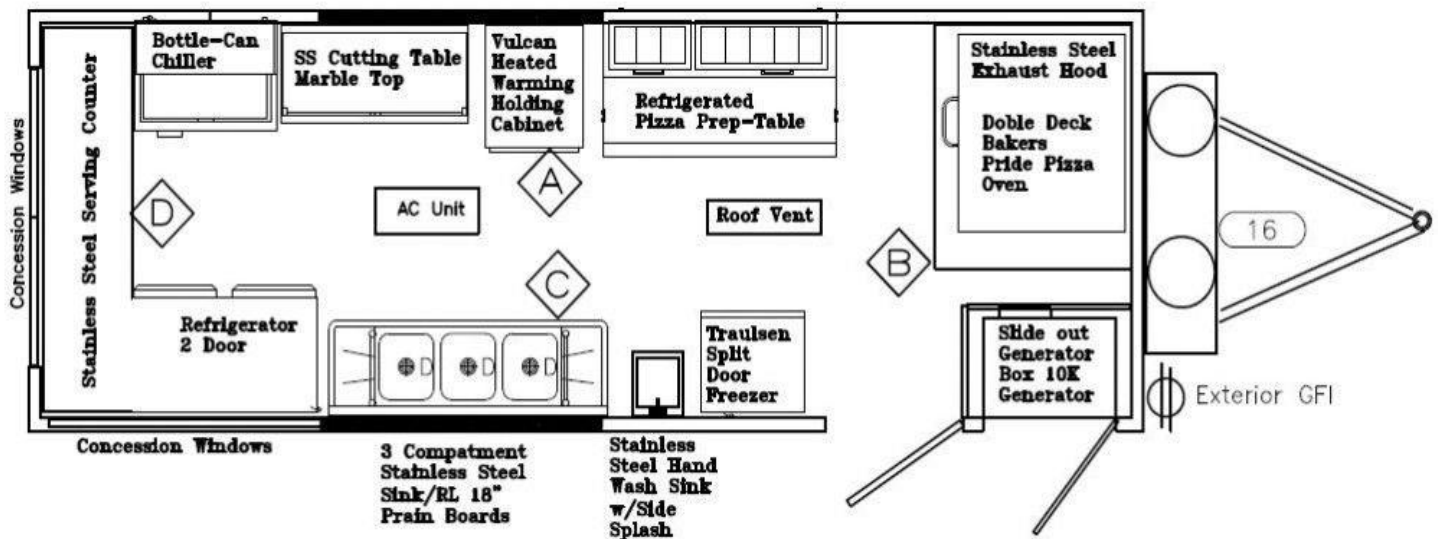

Note: Your floor plan does not need to be an engineer's copy, but it must have all the information from the Floor Plan/Equipment Layout checklist on the 1st page.

Please use the following page for Floor Plan:

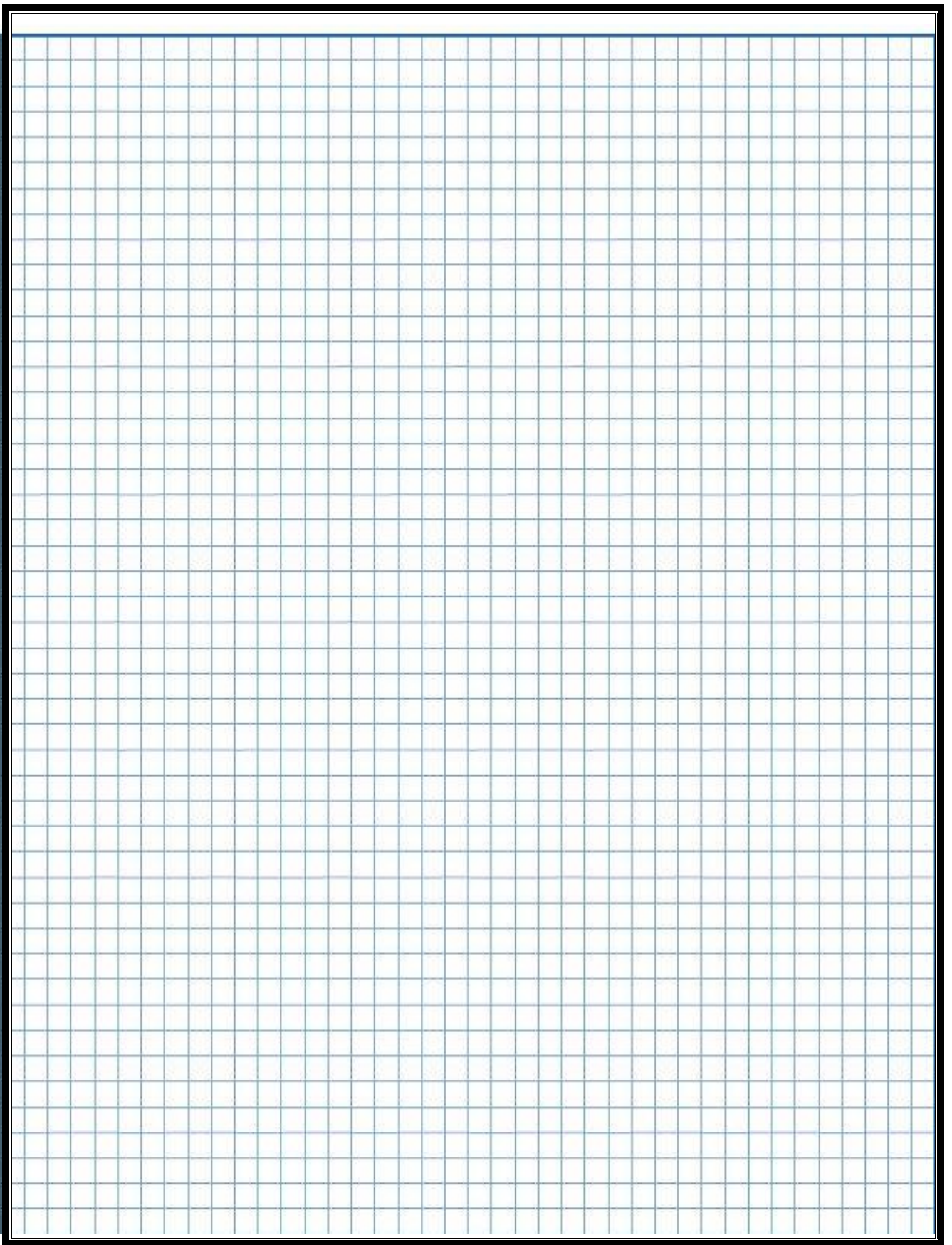

Food Handling

Procedures	Yes / No	If Yes, Where Will Procedure Take Place	
		Mobile	Commissary
Washing fruits and/or vegetables	<input type="checkbox"/> Yes <input type="checkbox"/> No		
Thawing frozen foods ¹	<input type="checkbox"/> Yes <input type="checkbox"/> No		
Food preparation - chopping, par-cooking, marinating, etc.	<input type="checkbox"/> Yes <input type="checkbox"/> No		
Cooking food	<input type="checkbox"/> Yes <input type="checkbox"/> No		
Cooling food ²	<input type="checkbox"/> Yes <input type="checkbox"/> No		
Reheating food	<input type="checkbox"/> Yes <input type="checkbox"/> No		
Refrigeration (cold holding) of foods	<input type="checkbox"/> Yes <input type="checkbox"/> No		
Steam table or other way of hot holding food	<input type="checkbox"/> Yes <input type="checkbox"/> No		

¹How you will thaw frozen foods:

²If cooling foods, one of the below processes must be in place. Please choose option a, b or c below:

- a. I have a licensed commissary where I will be cooling foods; or
- b. I will be using a commercial refrigeration unit(s) on the mobile unit; or
- c. I am providing a written cooling procedure accompanied by cooling logs for approval. To do this option, you must provide a written procedure for each food item you will be cooling with your packet.

Describe how foods will be rapidly cooled:

Will raw or undercooked animal products be served? ____Yes ____No If yes, list the specific animal products that will be served raw or undercooked (example: eggs, ground beef), and provide statement from Oregon Food Code 3-603.11 that will be in your menu:

Explain other procedures that you will be doing that have not been listed previously:

Note: Mobile food units newly licensed in Oregon may not utilize cold plates that do not have an associated power source, such as a battery, generator, or propane tank, as the sole means for temperature control.

OAR 333-162-0880

Three-Compartment Sinks/Dishwashing

Provide interior of sink basins dimensions in inches – **length x width x depth**

Dimensions of Interior of Sink Basins			How many drain boards
Length	Width	Depth	

--	--	--	--

Where will washing of equipment and utensils take place: Mobile unit three-compartment sink ____
 Licensed Restaurant or Commissary ____

Provide L x W x D for the interior basins of the three-compartment sink. Provide separate measurements for each sink basin if they are different sizes.
 To determine the minimum amount of water that must be dedicated for dishwashing purposes, you need to calculate the volume of your three-compartment sink. Measure the inside of the three-compartment sink basin in inches, then multiply Length x Depth x Width = ____ inches cubed. Multiply inches cubed by .0043 to convert to gallons. Multiply by 3 if all three sinks are the same size. This is your total volume. Double this number and compare to minimum of 30 gallons. The larger number is your minimum requirement.

Example: 10in x 10in x 14in = 1400 inches cubed for one basin of 3 compartment sink
 1400inches cubed x 3 basins = 4200 inches cubed
 4200 inches cubed x .0043 gallons = 18 gallons (total volume)
 18 gallons x 2 = 36 gallon minimum

An additional 5 gallons is required for handwashing.

Indirect plumbing (air gap) on three-compartment sink	Yes	No	Food preparation sink with indirect plumbing	Yes	No
	<input type="checkbox"/>	<input type="checkbox"/>		<input type="checkbox"/>	<input type="checkbox"/>

*Note: All sinks must provide water under pressure of a least 20 PSI. Gravity fed is not allowed.
 OAR 333-150-0000, 5-203.11*

Fresh Water Tank – Must Be Transparent

Dimensions of Fresh Water Tank (in inches)			
Length	Width	Depth	Capacity in gallons

--	--	--	--

Wastewater Tank – Must be 15% Greater than Fresh Water Tank

Dimensions of Wastewater Tank (in inches)			
Length	Width	Depth	Capacity in gallons ¹

--	--	--	--

How will the wastewater be removed and where will it be disposed from your wastewater tank?
(Operators may only hand-carry 20 gallons of wastewater by law.)

¹For a mobile food unit selling only beverages, such as coffee, espresso, or soda, and where most of the potable water supply is used in the product, the waste water retention tank may be at least one half the volume of the potable water storage tank. This determination must be made by the regulatory authority.

Operating Location/Schedule (if known)

Address:	I plan to operate at one location _____
	I plan to operate at multiple locations _____



Deschutes County Health Services
Environmental Health Division
2577 NE Courtney Dr., Bend OR 97701

PHONE: (541) 322-7400
FAX: (541) 322-7604

**MEMORANDUM OF COMMISSARY
OR WAREHOUSE USAGE/VERIFICATION**

(This agreement expires December 31st of the year issued)

The licensed food service establishment known as _____

RESTAURANT NAME

located at _____,

RESTAURANT STREET ADDRESS

CITY

STATE

ZIP

hereby agrees to provide access for usage as a commissary or warehouse to _____

MOBILE UNIT OWNER

to operate mobile food unit _____.

MOBILE UNIT NAME

All food items used by the mobile unit owner/operator will be properly stored at this commissary/warehouse, and approved dishwashing facilities are also provided with which to clean and sanitize utensils used in the mobile unit per ORS Chapter 624. This licensed food service establishment is to be used for all preparation and storage of food items and dishwashing activities as needed. The licensee of the commissary/warehouse is responsible for all food service operations conducted on the commissary/warehouse premises and conducted on the licensed food service establishment in conjunction with the mobile unit.

The agreement between the above-mentioned two parties is valid for _____ and may be

LICENSING YEAR

renewed in writing after that date. This agreement expires December 31st of the year issued. However, in the event this or any renewed agreement for commissary/warehouse usage is terminated, the licensed food service establishment and the mobile unit owner agree to notify and understand that the mobile unit license shall be immediately suspended by the Deschutes County Environmental Health Division. All parties also agree that, in the event of the termination of this or any renewed agreement for commissary/warehouse usage, all food service operations must immediately discontinue until the mobile unit owner secures the services of an approved commissary/warehouse and provides another valid Memorandum of Commissary/Warehouse Usage/Verification to the Deschutes County Environmental Health Division. This agreement terminates if the food service establishment does not have a current license to operate. This agreement also terminates if the mobile unit owner does not have a current license for the commissary/warehouse in the name of the mobile unit owner.

SIGNATURE of food service establishment owner

date signed

PRINTED NAME of food service establishment owner

() _____
phone number

SIGNATURE of mobile food unit operator

date signed

SIGNATURE of County Sanitarian

date signed



Environmental Health Division Mobile Food Unit Restroom Requirement Form

6.402.11 Convenience and Accessibility.

(E) For mobile food units:

- (1) On-board toilet facilities are not applicable to most mobile food units. If a unit is not so equipped, then the mobile food unit must operate within 500 feet of an accessible restroom facility. Mobile food units that operate on a designated route, and which do not stop at a fixed location for more than two hours during the workday, shall be exempt from this rule.
- (2) Mobile food units that do not provide on-board restroom facilities under Section (1) of this rule must have restroom facilities that will be accessible to employees during all hours of operation. The restroom facilities must have a handwashing system that provides potable hot and cold running water and meets the requirements of OAR 333-150-0000, §§ 6-301.11, 6-301.12, 6-301.20 and 6.302.11. Employees may use a restroom located in a private home or a portable toilet to satisfy this requirement.

Mobile Food Unit:

Name of mobile food unit: _____

Phone number: _____

Email: _____

Location (for more than two hours): _____
Street Address City, State

Days of week / dates the location will be used: _____

Business hours (at this location): _____

Mobile Food Unit Owner's Name (printed) Mobile Food Unit Owner's Signature Date

Mobile food units that remain at the same location for more than two hours or which provide any seating must have restroom facilities available. Please answer the questions below.

- 1. Is your mobile food unit at the same location for more than two hours? Yes No
- 2. Is customer seating provided at the mobile food unit? Yes No

If your answer is yes to one or both of the questions above, a restroom facility must be available for your mobile food unit, and you are required to provide the additional information requested below. (Complete a separate form if you will be at more than one location for more than two hours.)

Location of Restroom Facilities:

Name of restroom location: _____

Address: _____ Phone number: _____
Street Address City, State

Hours the restroom is available for use: _____

Authorization to Use Restroom Facilities:

Printed name of person authorizing use of restroom facilities by Mobile Food Unit staff _____

Signature of person authorizing use of restroom facilities by Mobile Food Unit staff _____ Date _____

Mobile Food Unit Owner (Print): _____

Signature Date

EMPLOYEE ILLNESS POLICY

A COPY OF THIS POLICY IS TO BE PROVIDED TO EACH NEW HIRE AND TO EACH CURRENT EMPLOYEE WHO HAS NOT RECEIVED THIS POLICY IN THE PAST. ALSO, THIS POLICY IS TO BE POSTED WITHIN THIS FACILITY AND ALL EMPLOYEES NOTIFIED OF WHERE IT IS POSTED. THE PERSON IN CHARGE DURING EACH WORK SHIFT MUST BE ABLE TO SHOW HEALTH INSPECTORS WHERE THIS POLICY IS POSTED AND ABLE TO DISCUSS THIS POLICY WITH EMPLOYEES AND HEALTH INSPECTORS.

Reference Oregon Food Sanitation Rules 2-201.11; 2-201.12, and 2-201.13 concerning employee illness. The Oregon Food Sanitation rules can be viewed and/or downloaded in its entirety at the following website:

<http://public.health.oregon.gov/HealthyEnvironments/FoodSafety/Pages/rules.aspx>

☐ ALL NEW EMPLOYEES ARE TO INFORM MANAGEMENT OF THE FOLLOWING AT TIME OF HIRING AND AGREE TO REPORT TO MANAGEMENT SUCH CONDITIONS SHOULD THEY OCCUR DURING THEIR EMPLOYMENT AT THIS FACILITY:

(Food Code Rules Annex Form 1-A and Annex Form 1-B located towards back of food rules can be used to collect relevant past medical history and employee reporting agreement requirements.)

1. If suffering from diarrhea, vomiting, Jaundice (yellowing of skin or eyes), or sore throat with fever. Employees will not come to work when experiencing these symptoms. Employees who experience undiagnosed diarrhea or vomiting will not return to work for at least 24 hours (72 hours is recommended) after their symptoms have ended.
2. If currently or in the past diagnosed or presumptive with any of these medical conditions: Norovirus, Hepatitis A, Typhoid Fever, Shigellosis, *E. coli* 0157:H7, or other EHEC/STEC condition. *If a new hire or current employee is diagnosed or presumptive with any of these conditions, then this facility will immediately notify the Health Department (phone 541-322-7400) and exclude this individual from this facility until lab tests confirm that the employee is free of pathogens relating to any of these conditions, or as otherwise allowed by the Health Department.*
3. If they have been exposed to or suspected of causing any confirmed outbreak with regard to any of the medical conditions outlined in #2, above. When and where?
4. If they have a household member diagnosed with any of the medical conditions outlined in #2, above.
5. If they have a household member attending or working in a setting experiencing a confirmed outbreak as related to the medical conditions outlined in #2, above.
6. Name, address, and telephone number of their health practitioner or doctor.

☐ FOOD EMPLOYEES WITH LESIONS (E.G. OPEN SORES, CUTS, DEEP SCRAPES OR PUSS FILLED GASHES) SHALL BE EXCLUDED OR RESTRICTED FROM WORK DUTIES UNLESS:

1. A lesion on the hands or wrists is protected with an impermeable cover such as a finger cot and a single use glove is worn.
2. A lesion on exposed portions of the arms is protected with an impermeable cover.
3. A lesion on other parts of the body is protected with a dry, durable, tight-fitting bandage.